

MMK Folknáře 70 40501 Děčín www.mmk.cz mk.model@volny.cz

35054

TATRA T 141

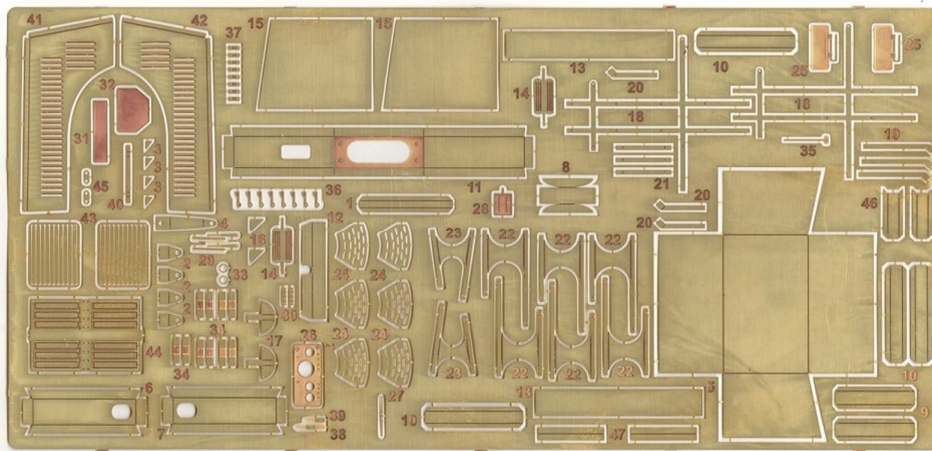

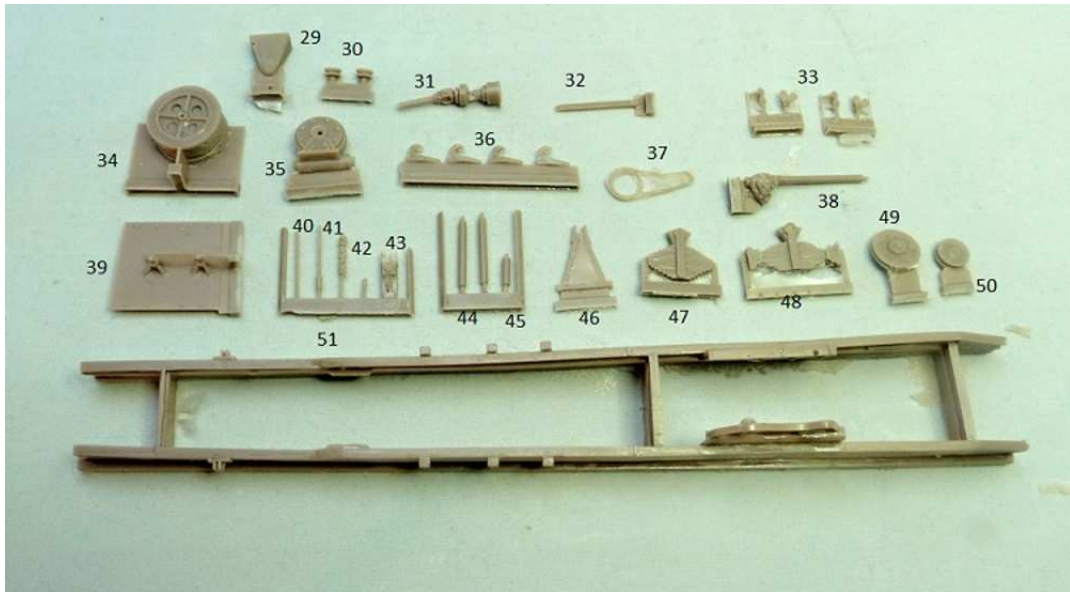
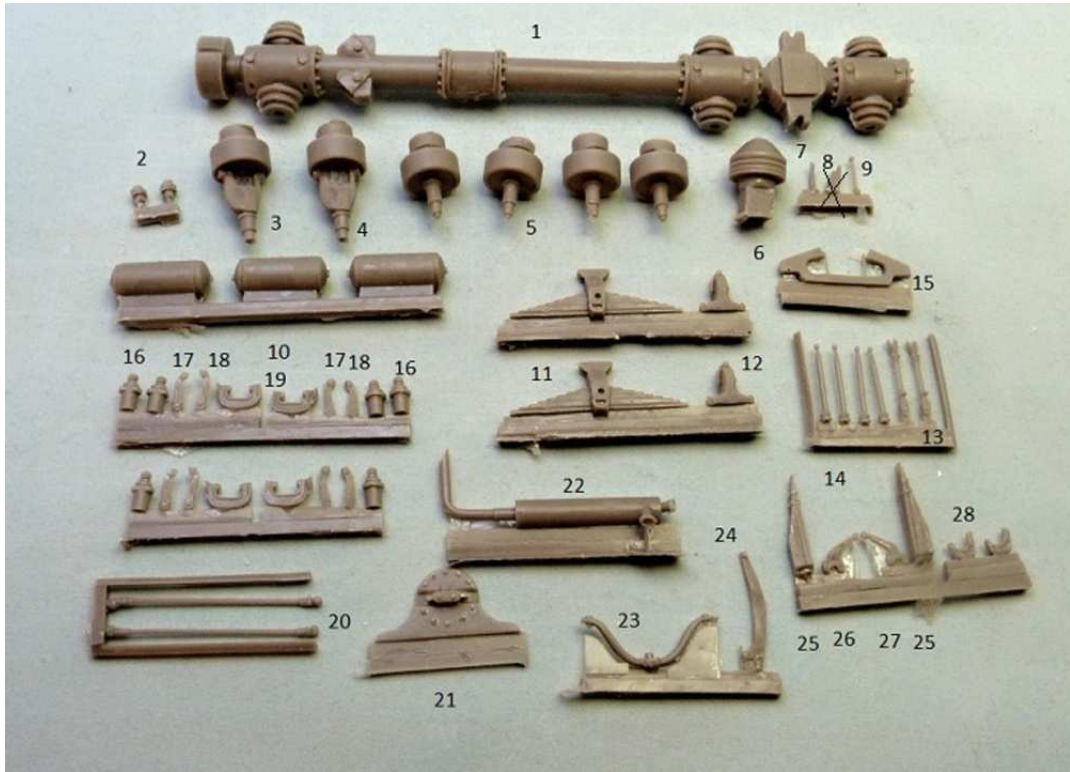

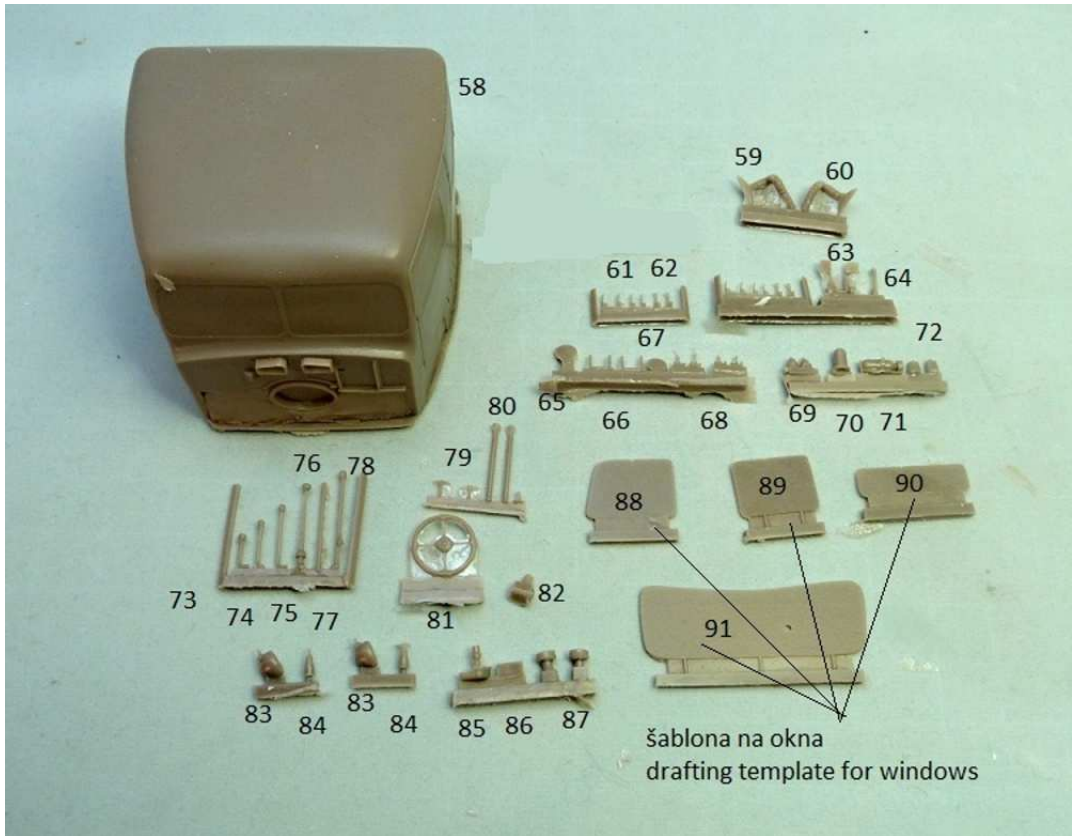
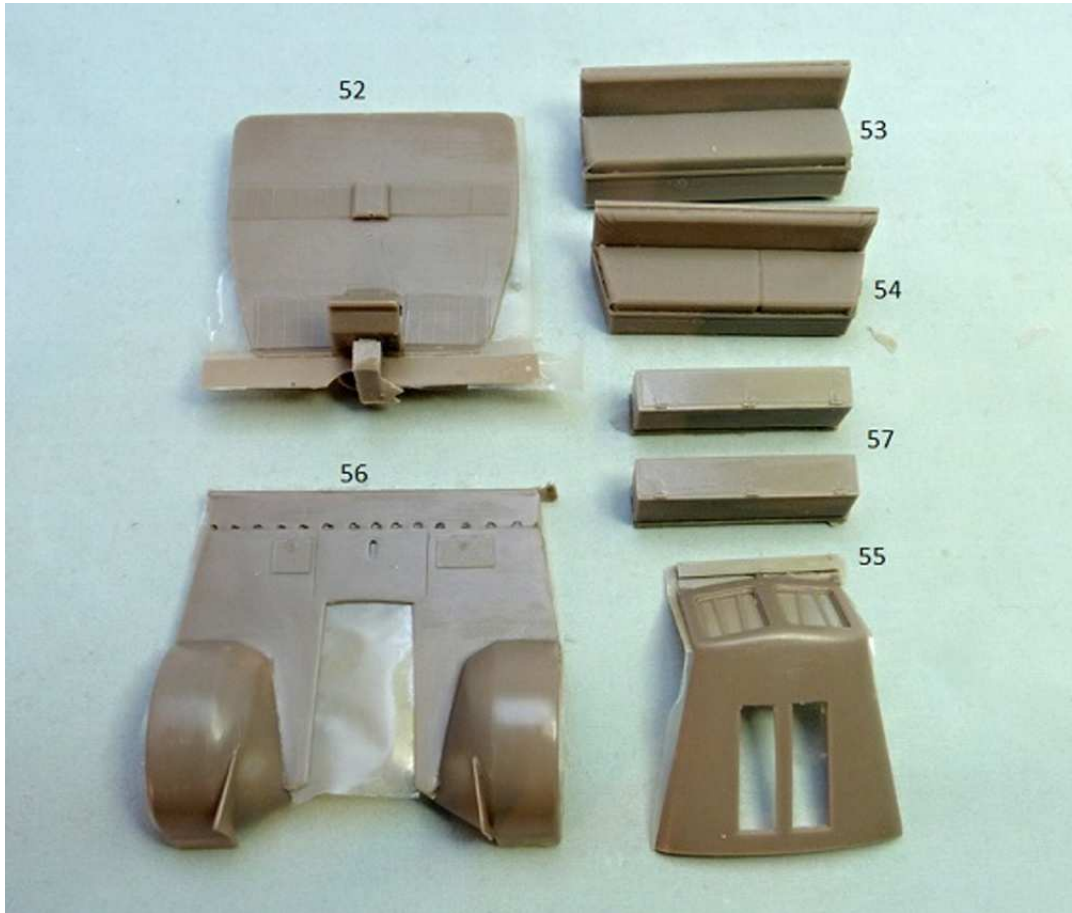

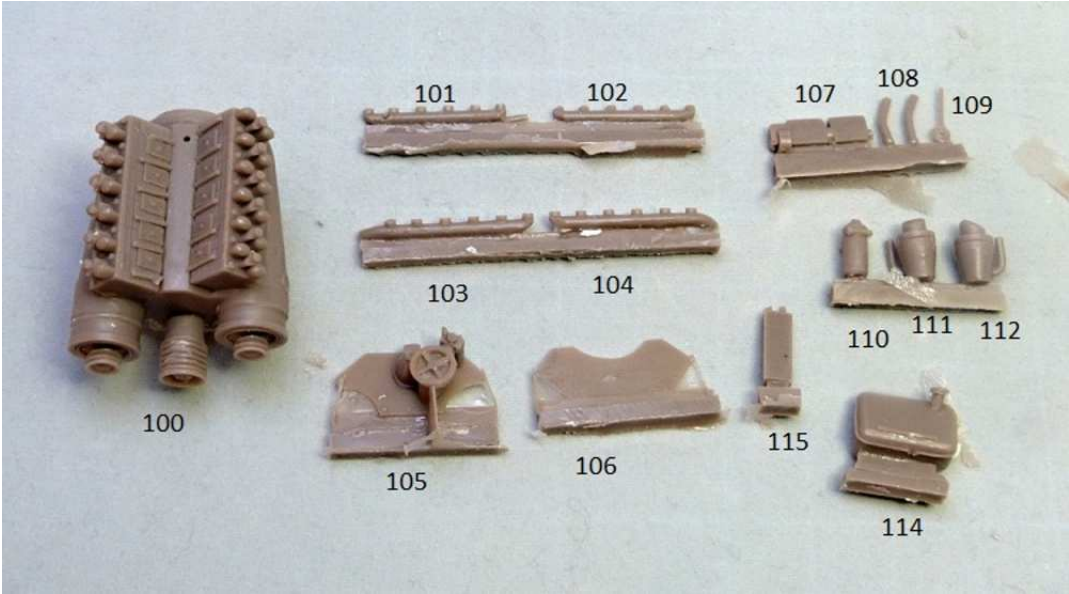
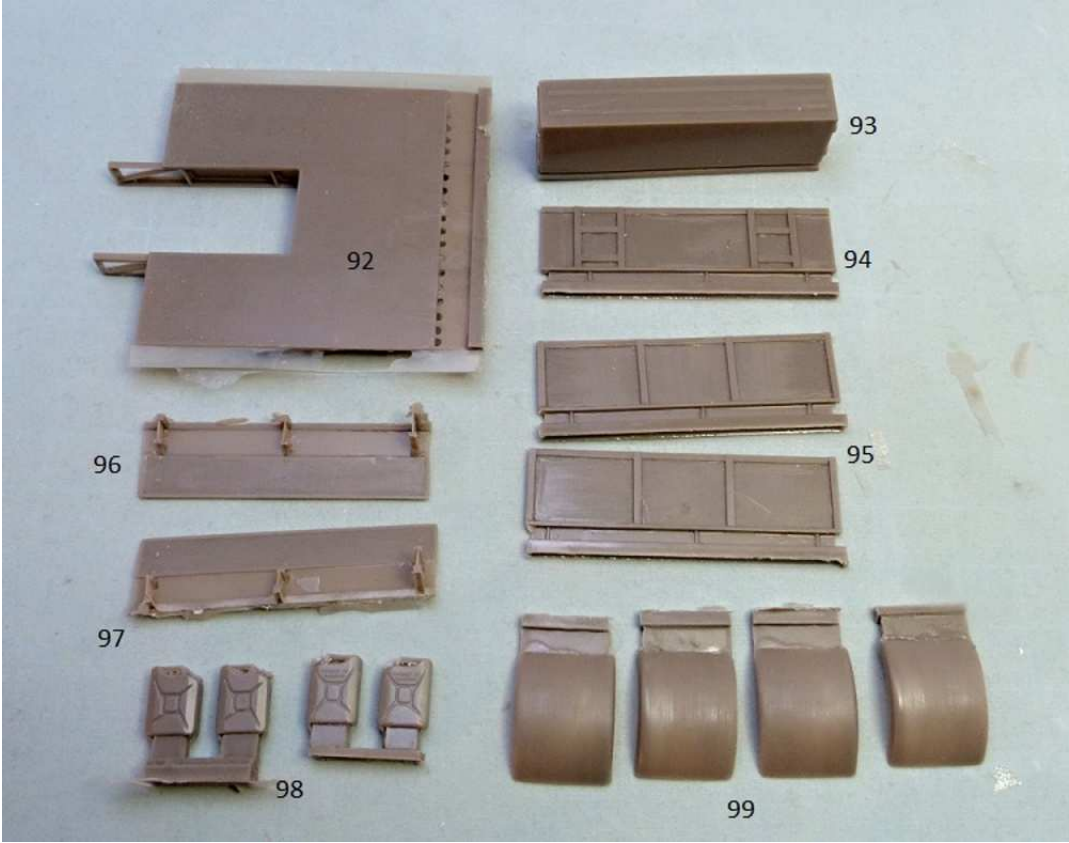

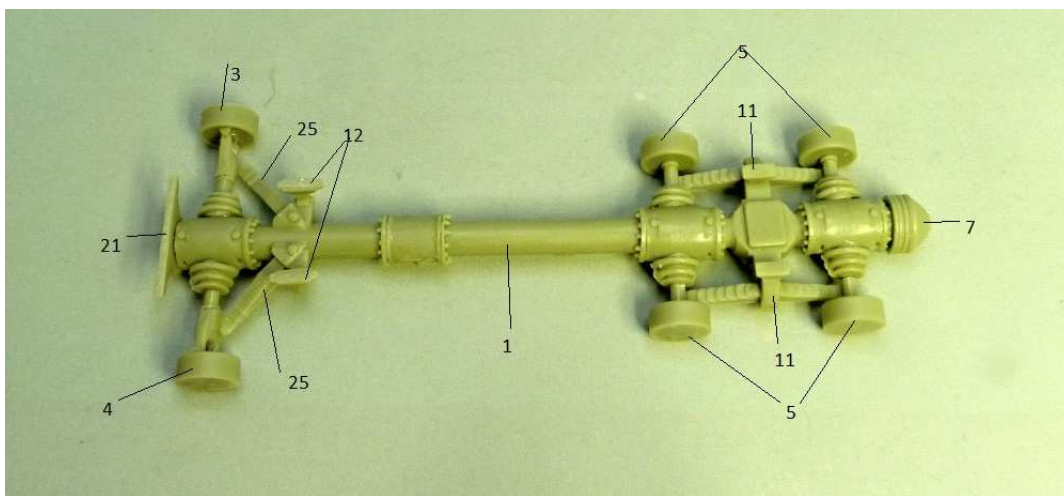
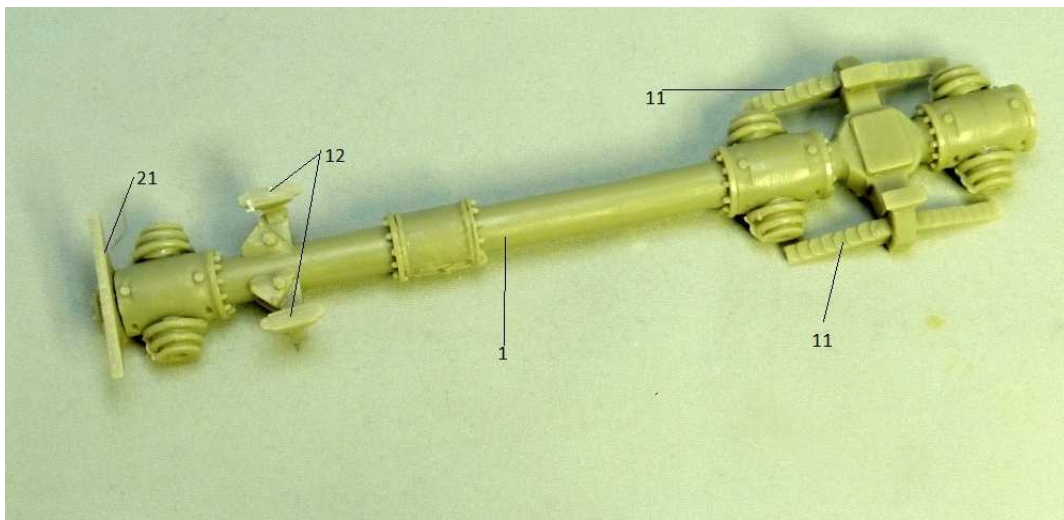
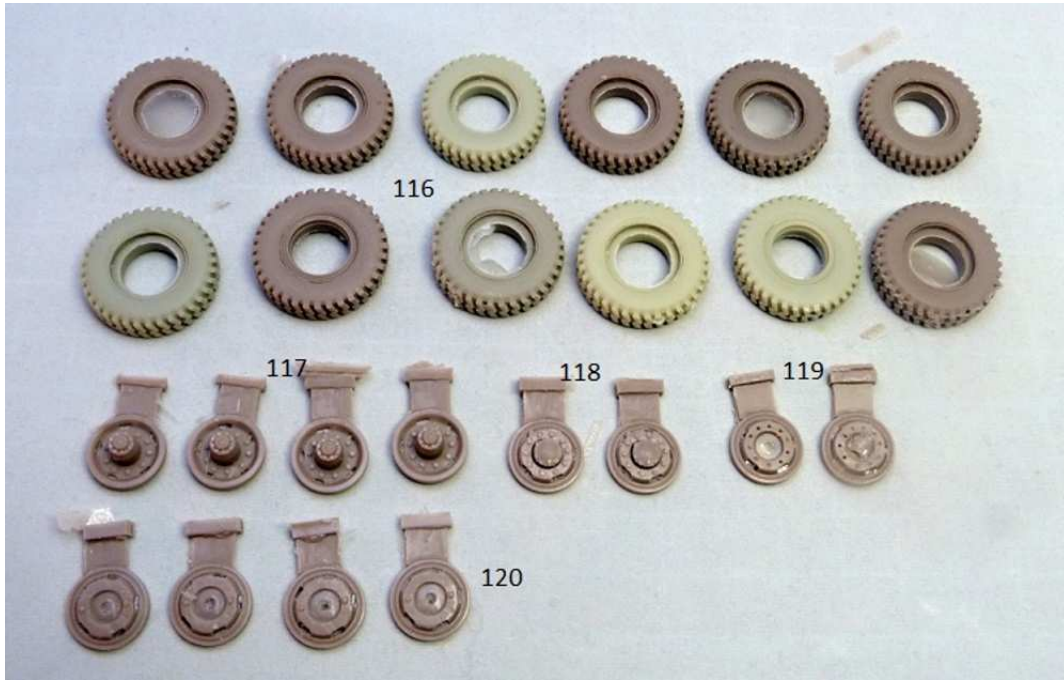

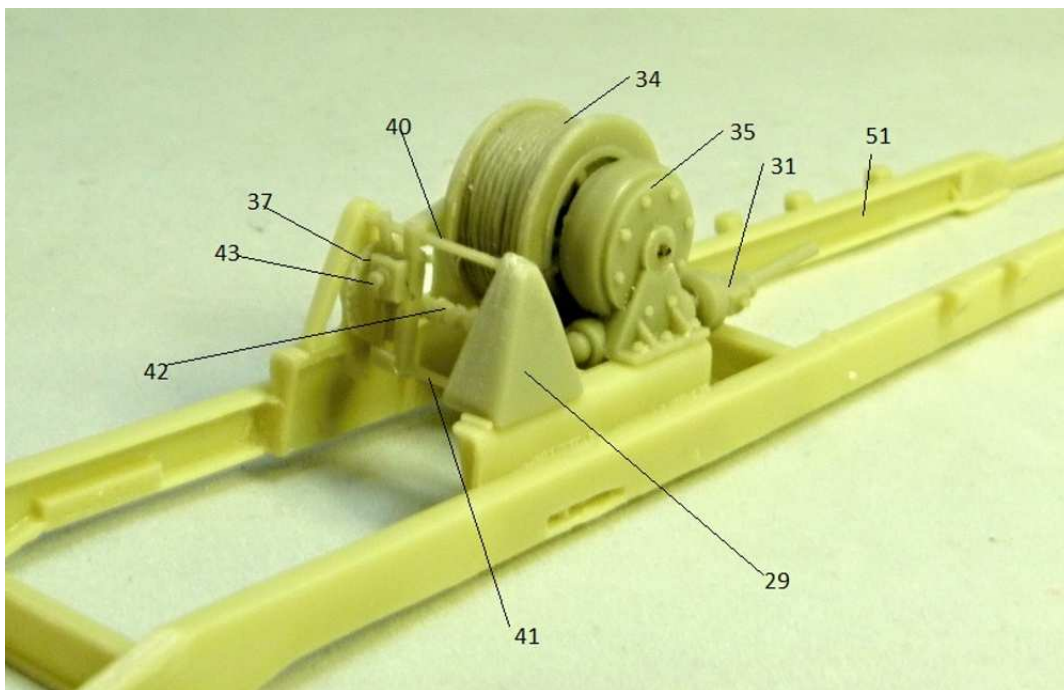
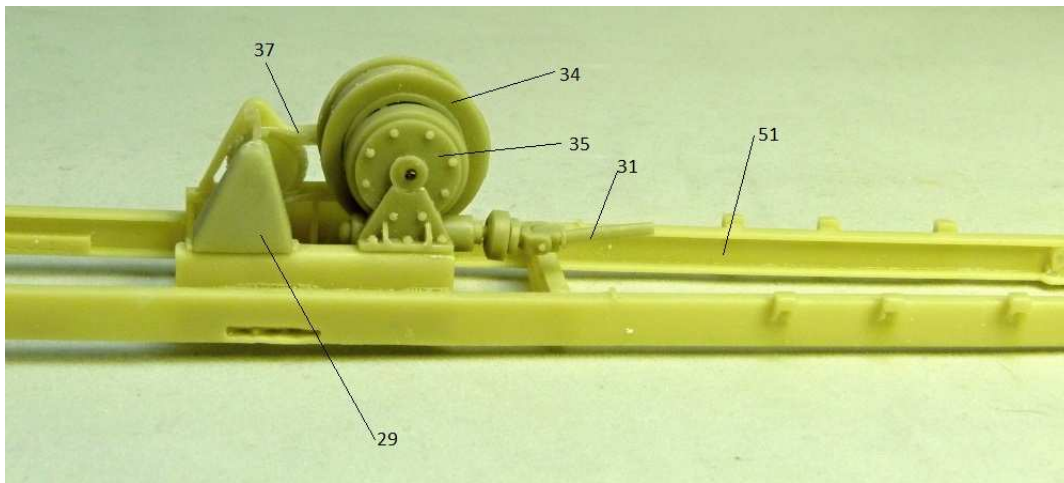
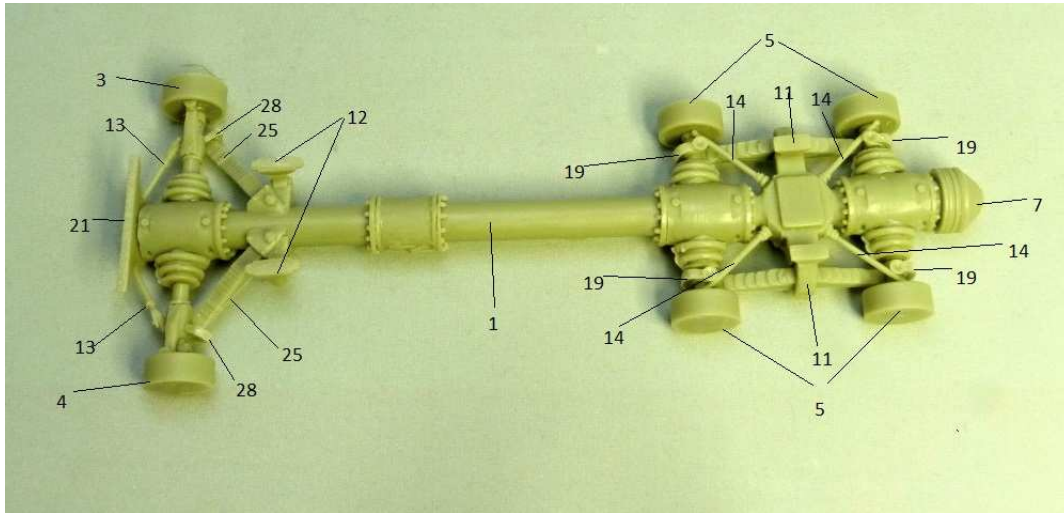

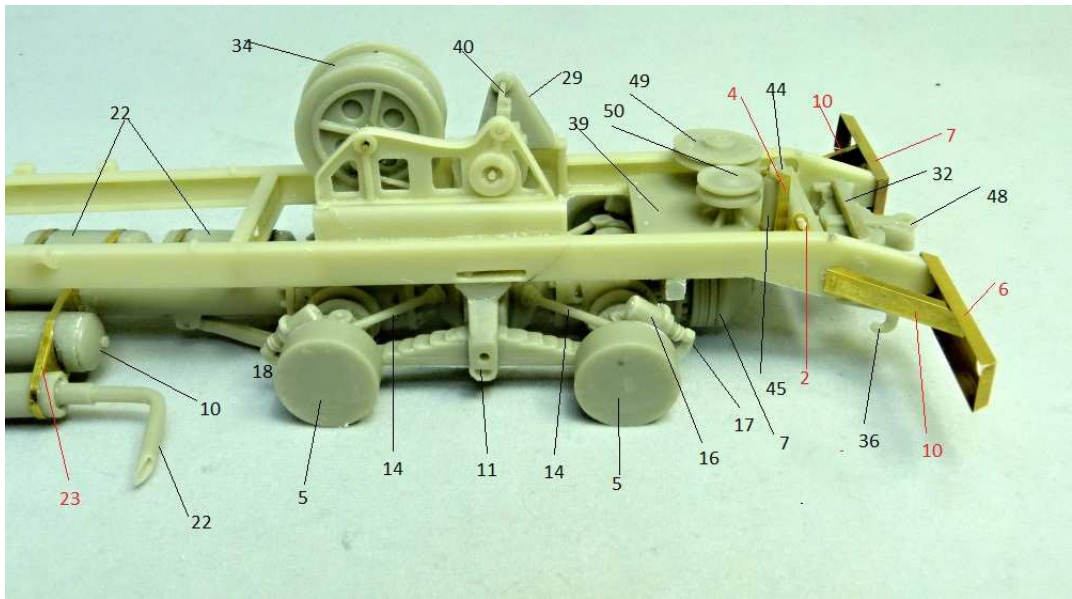
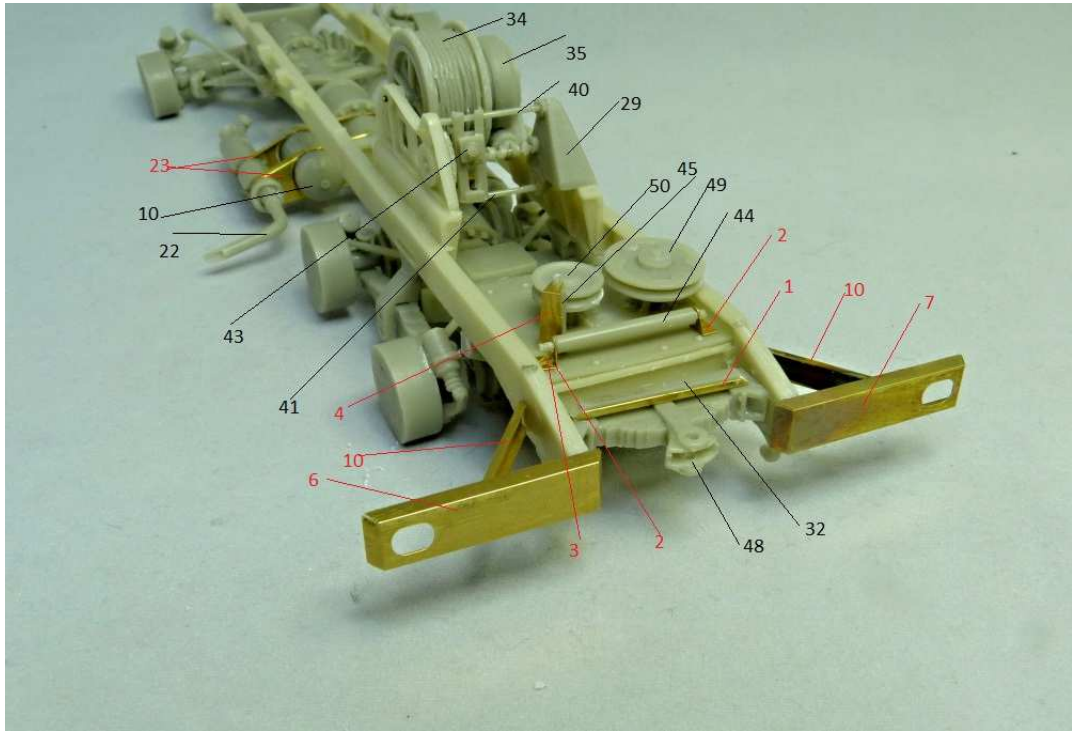

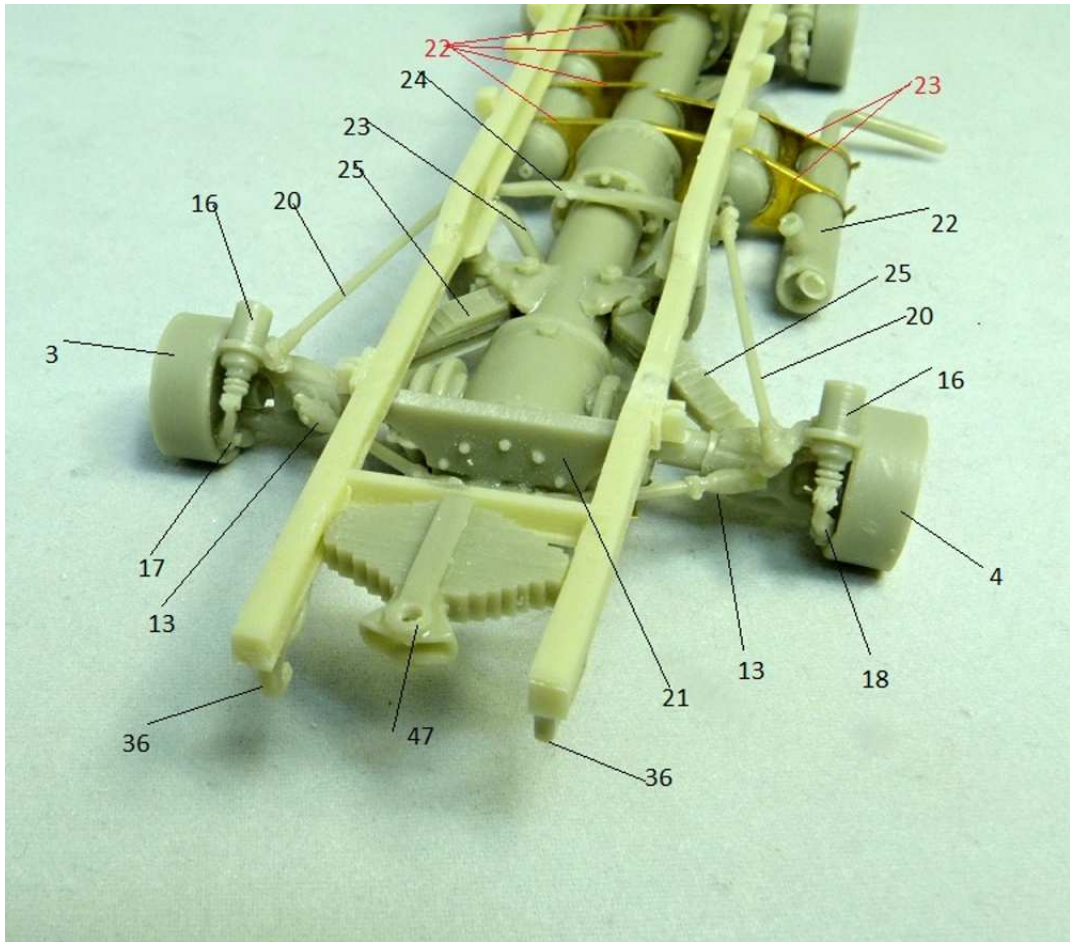
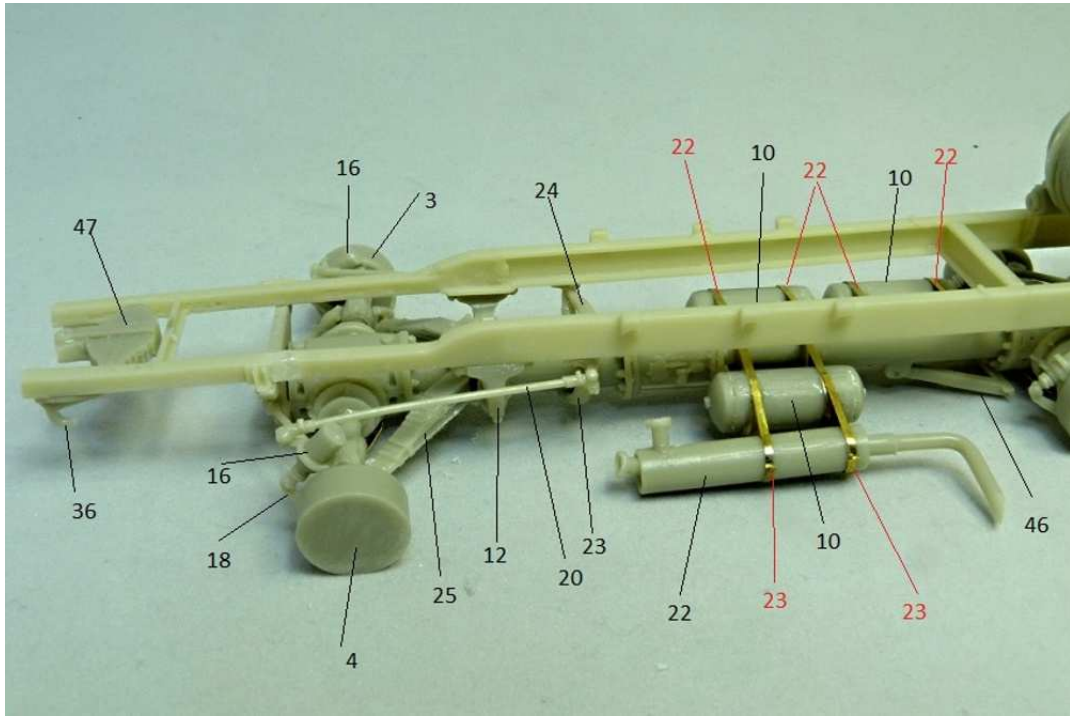

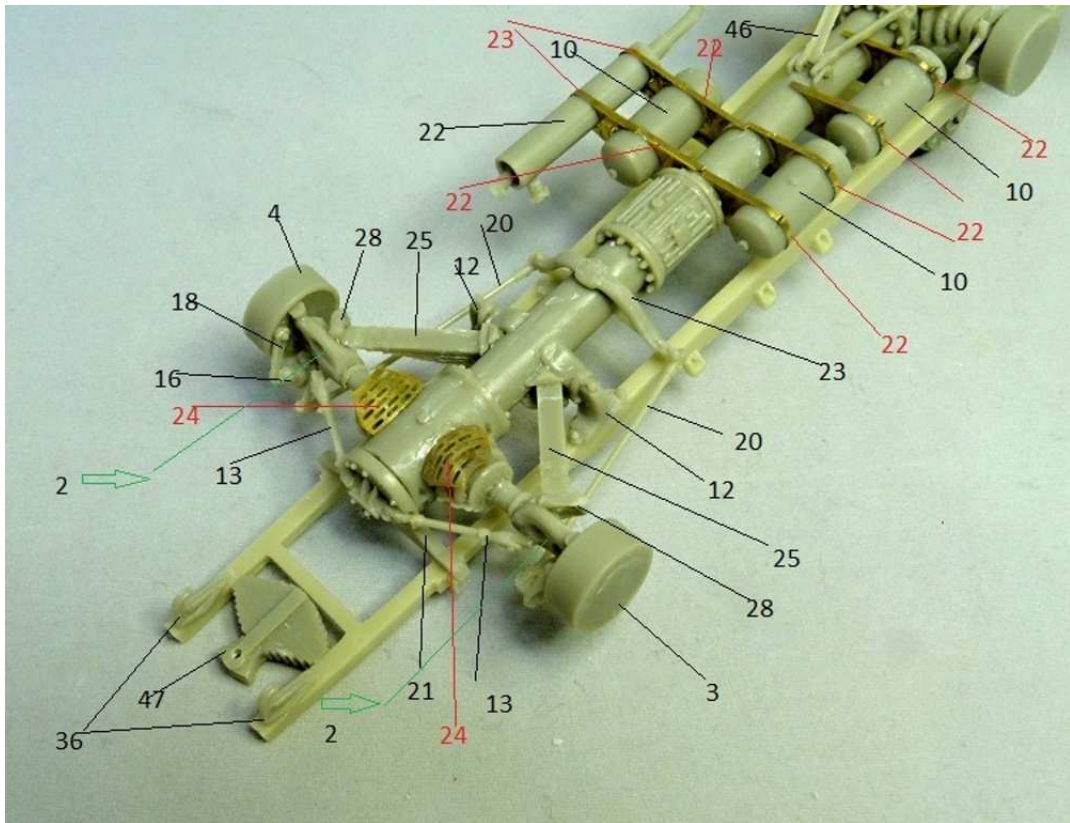
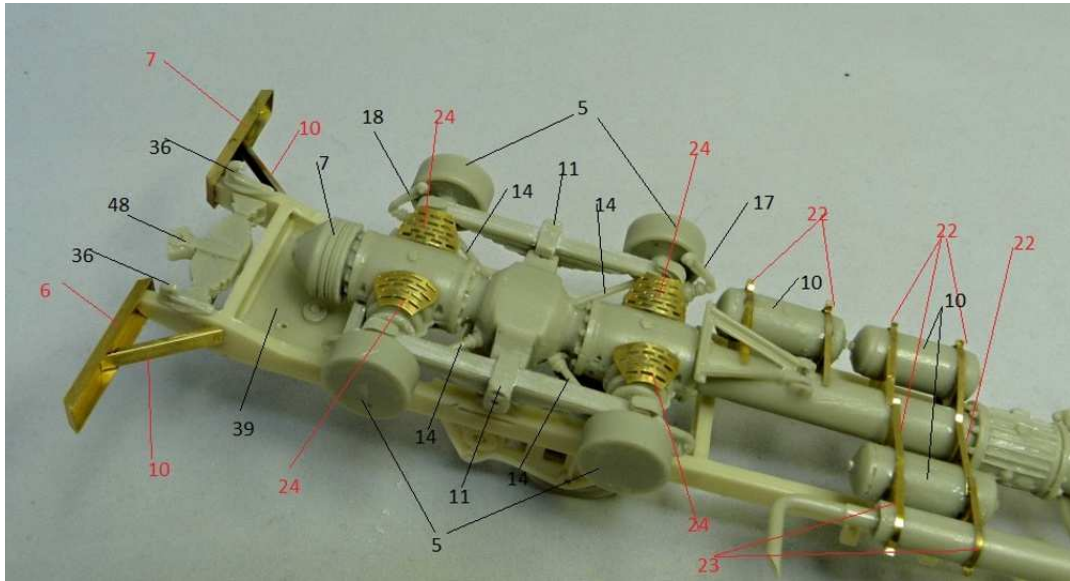

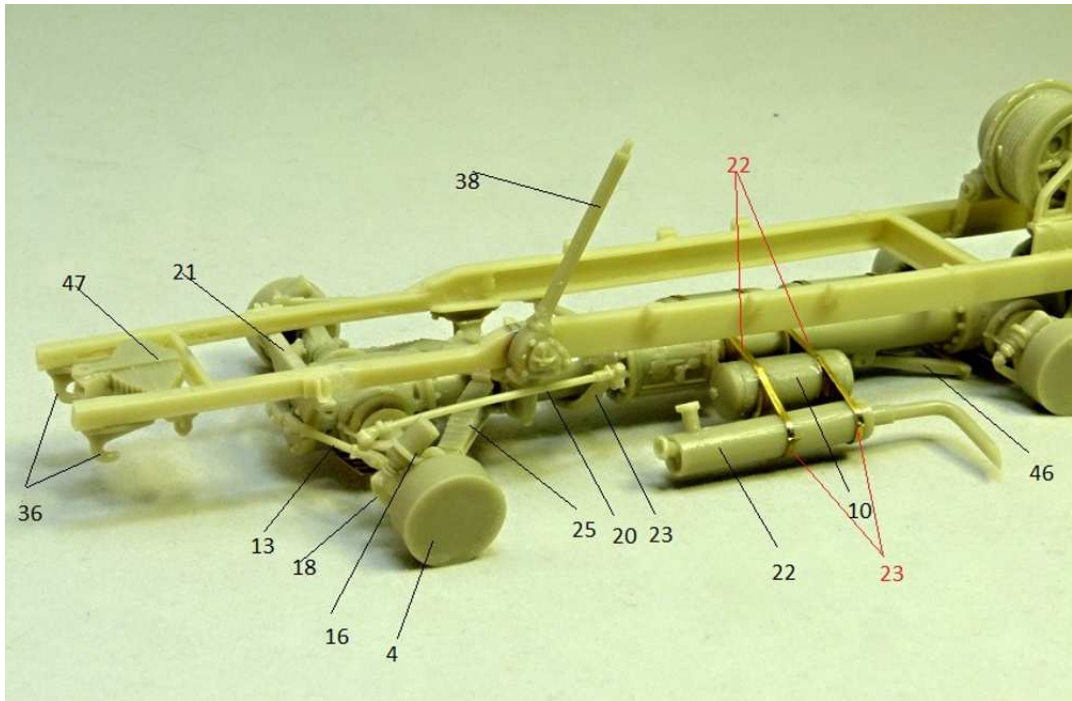
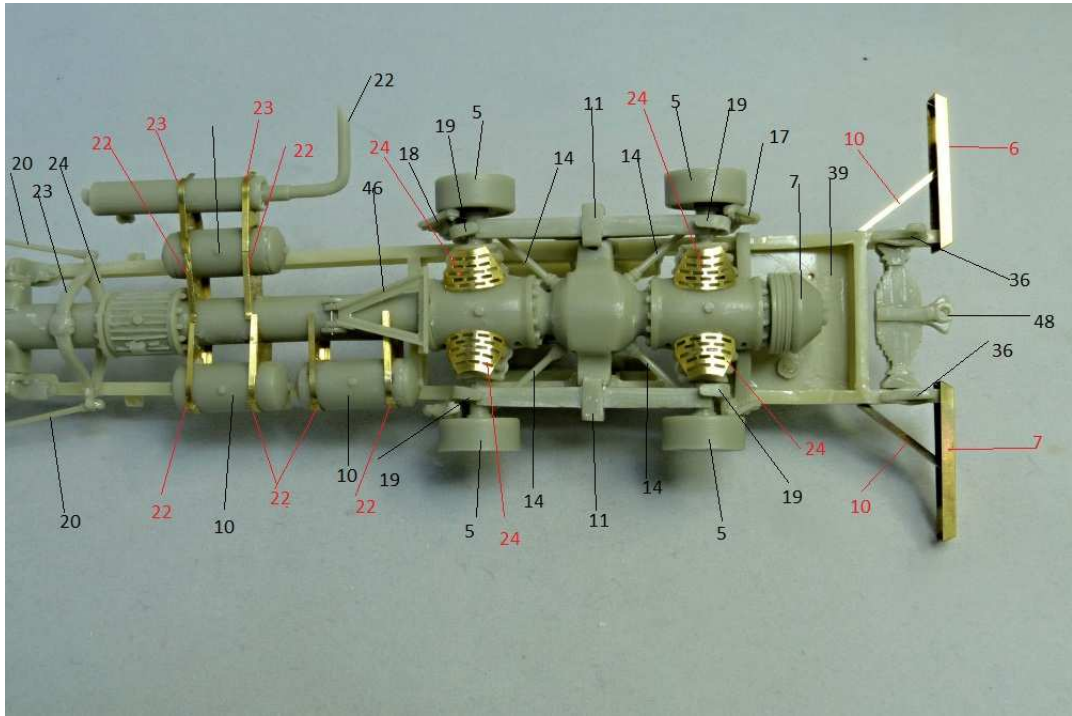

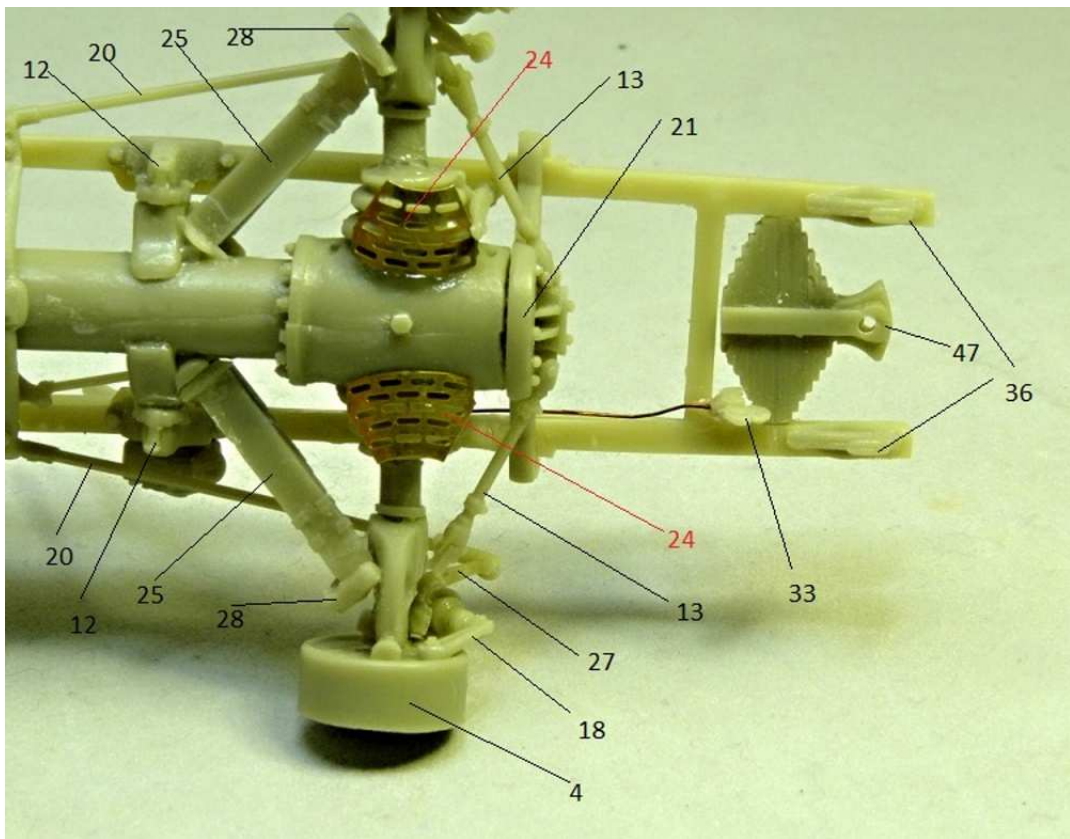
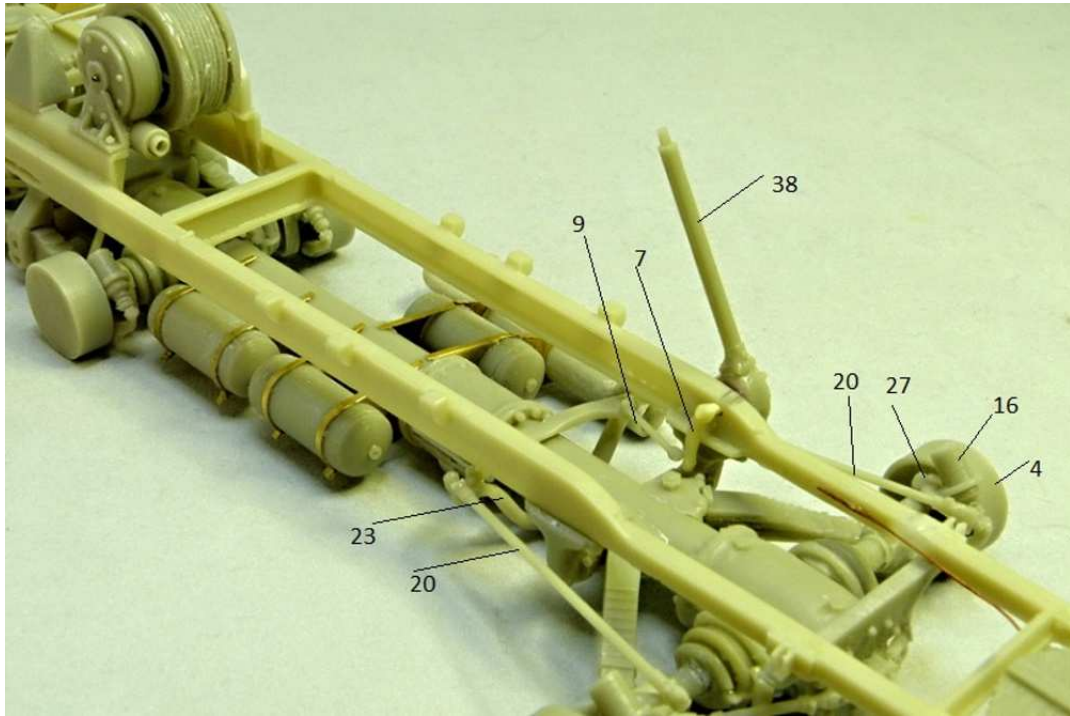

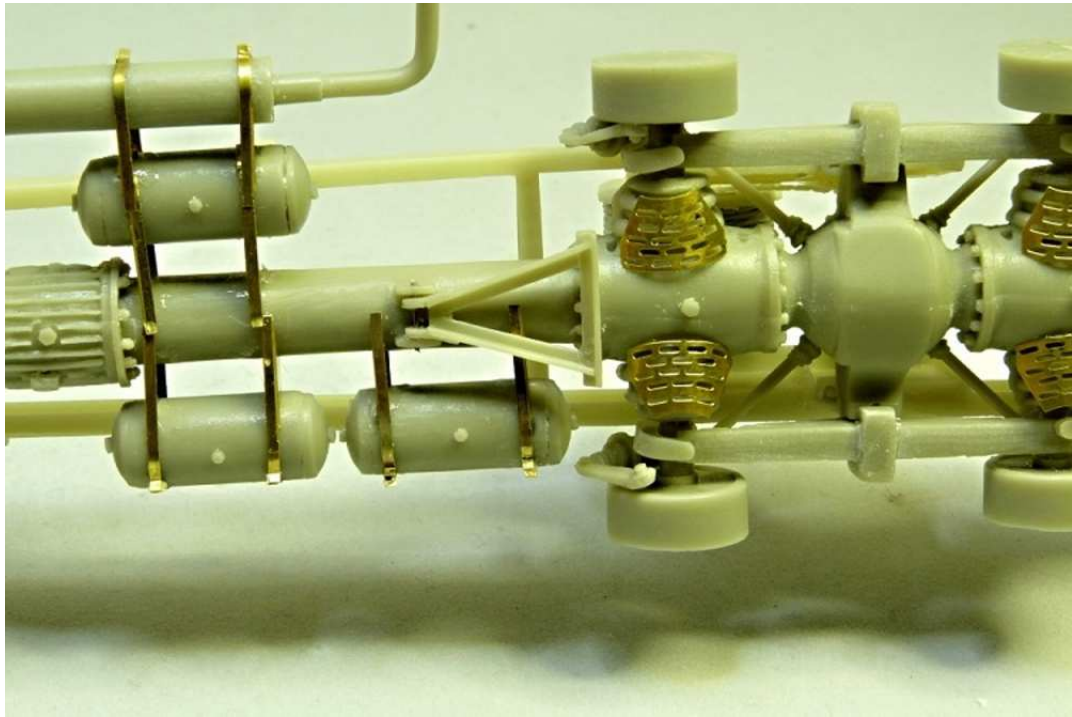
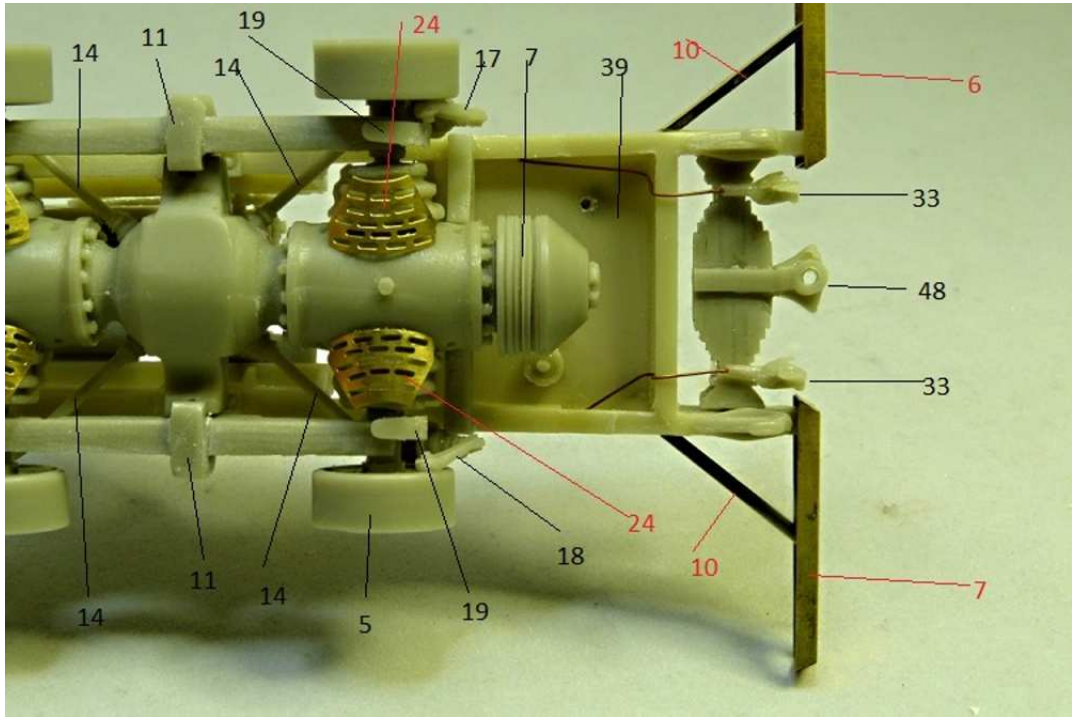

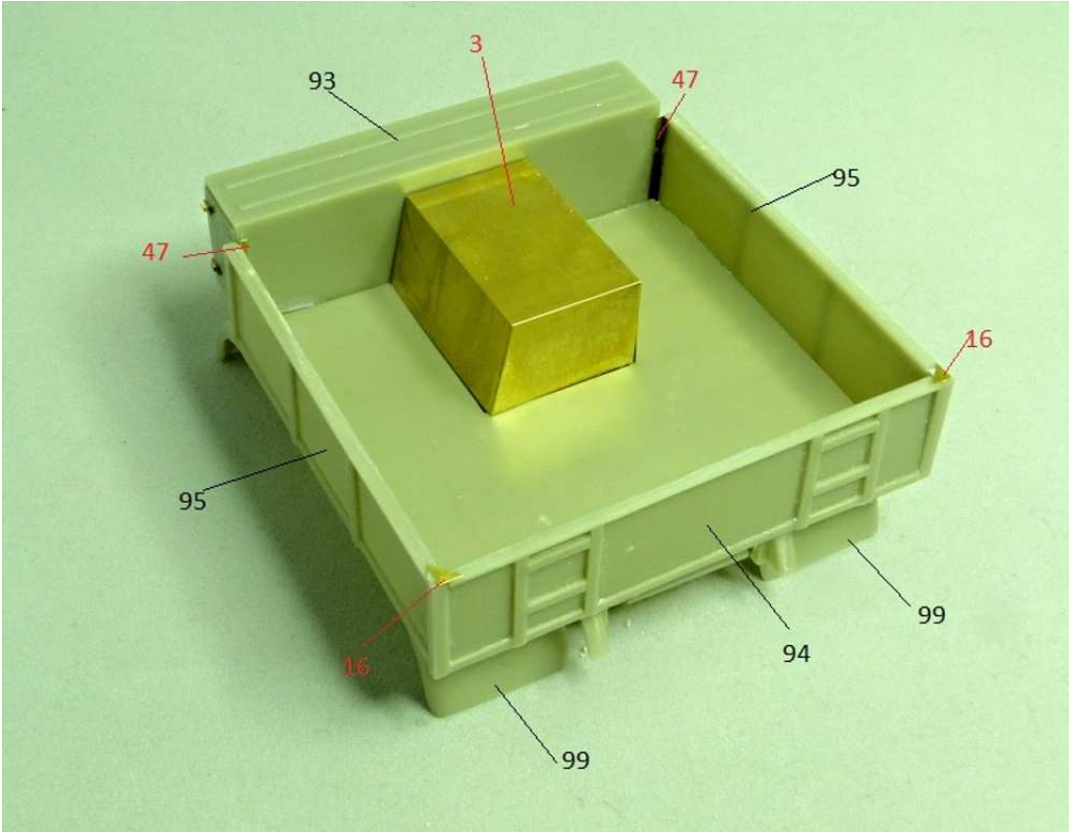
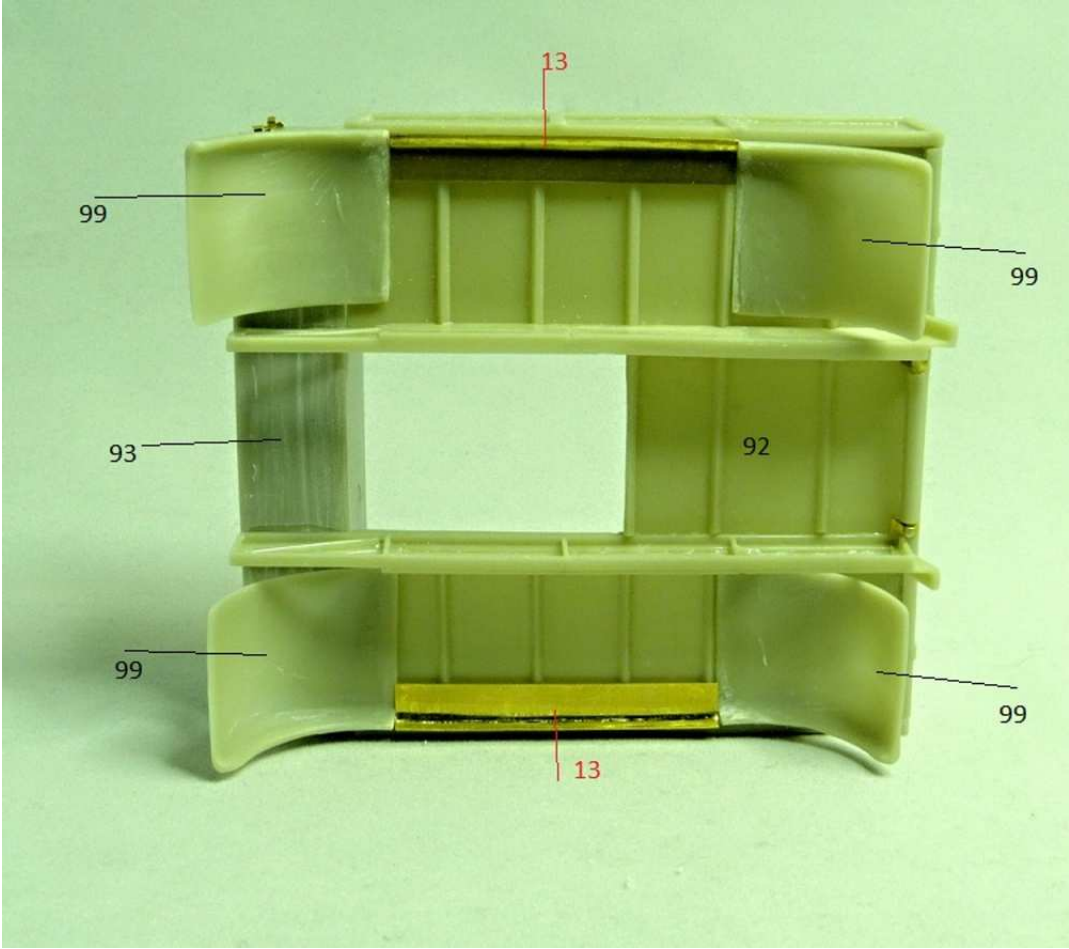

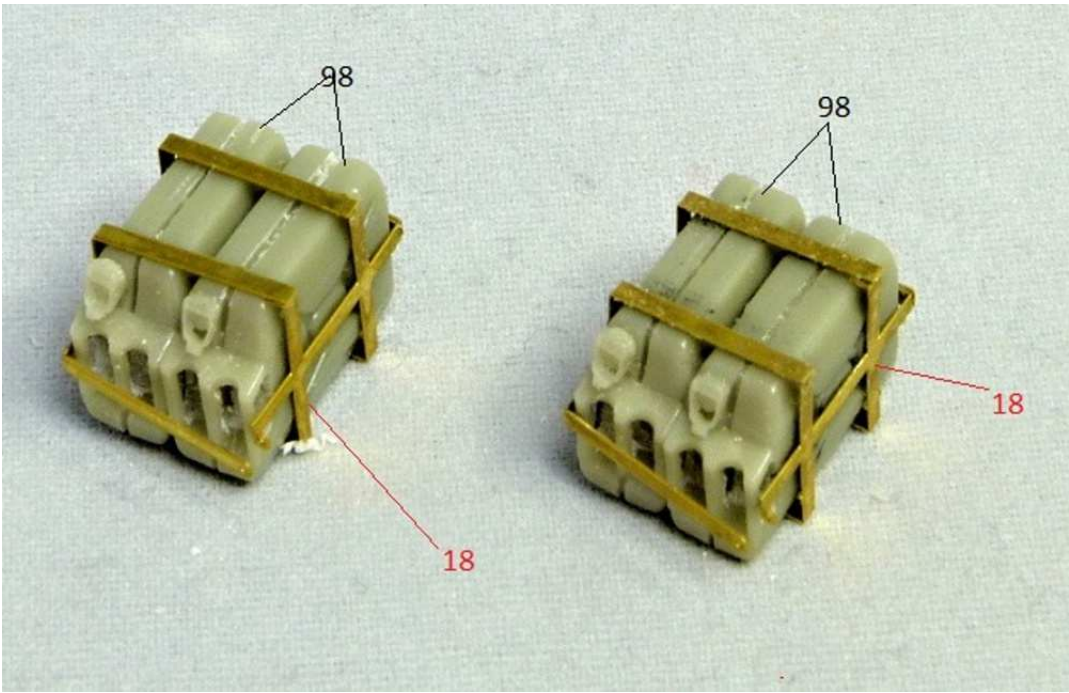
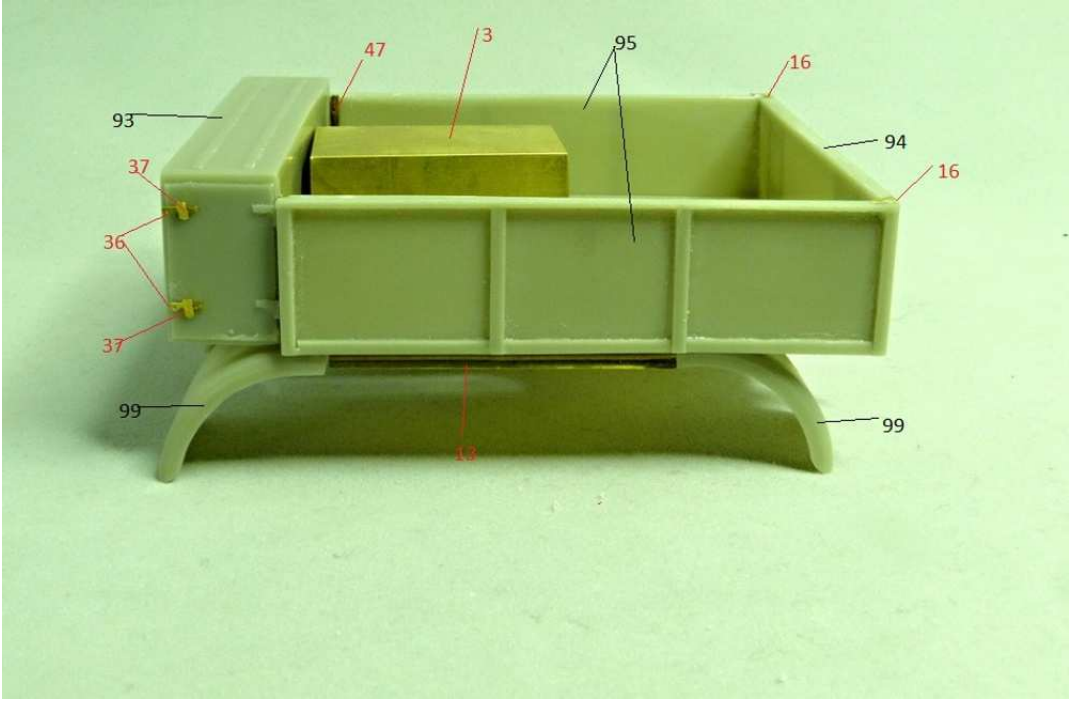

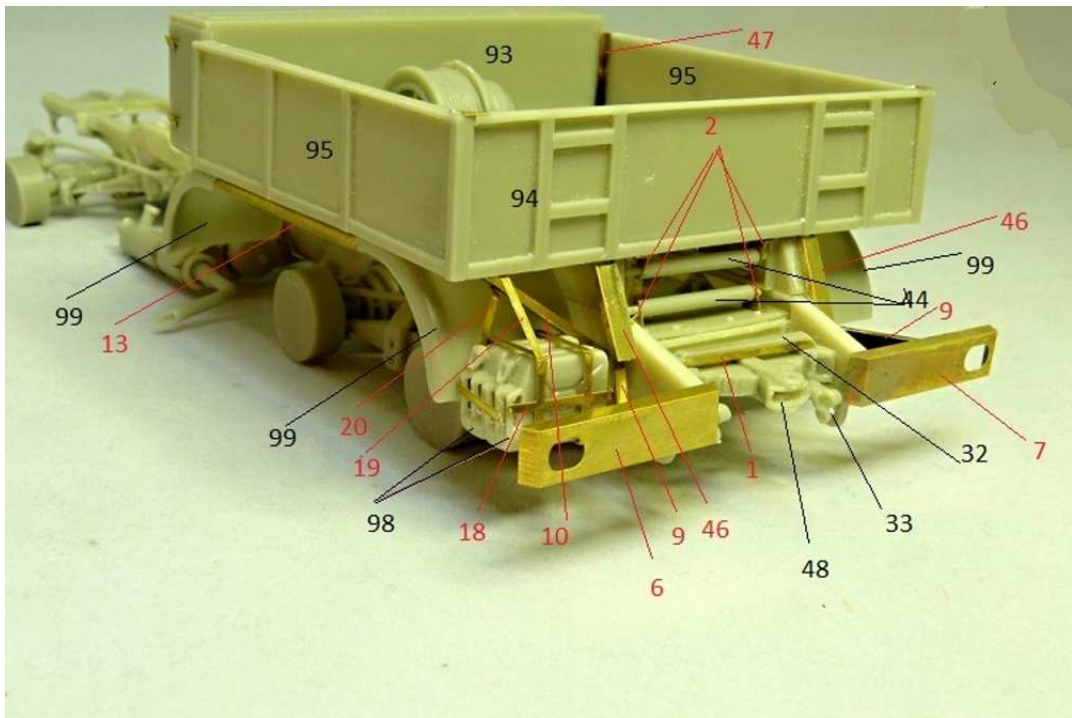
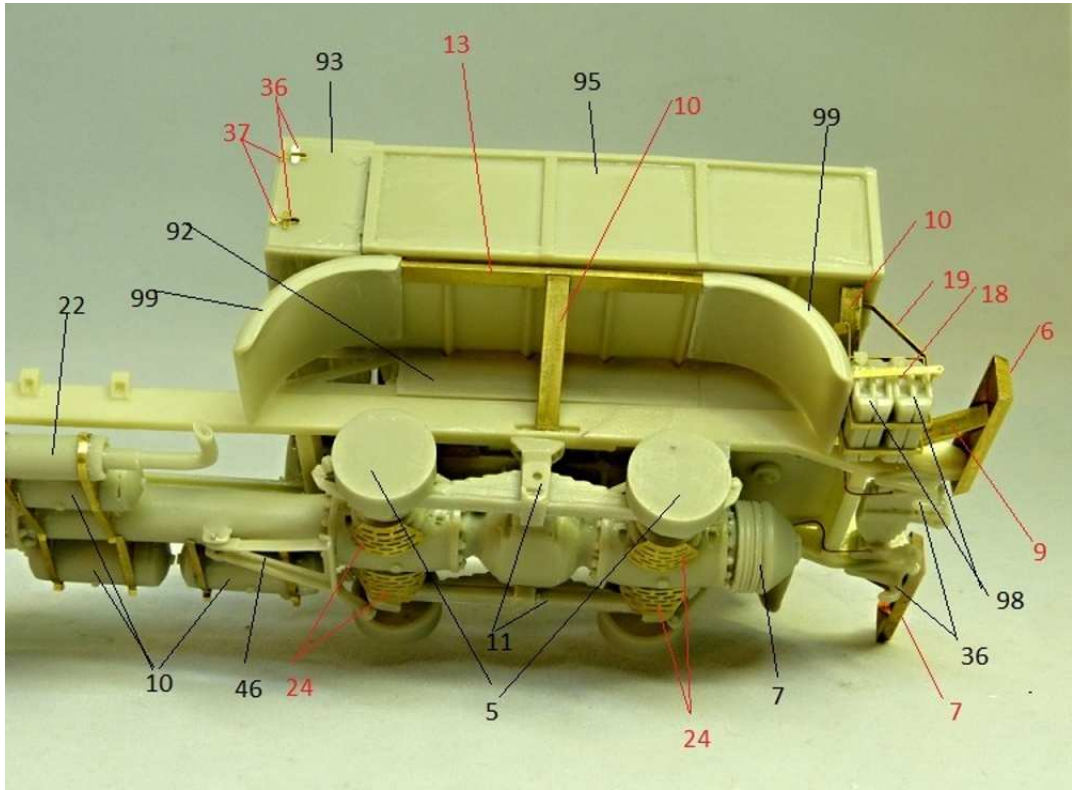

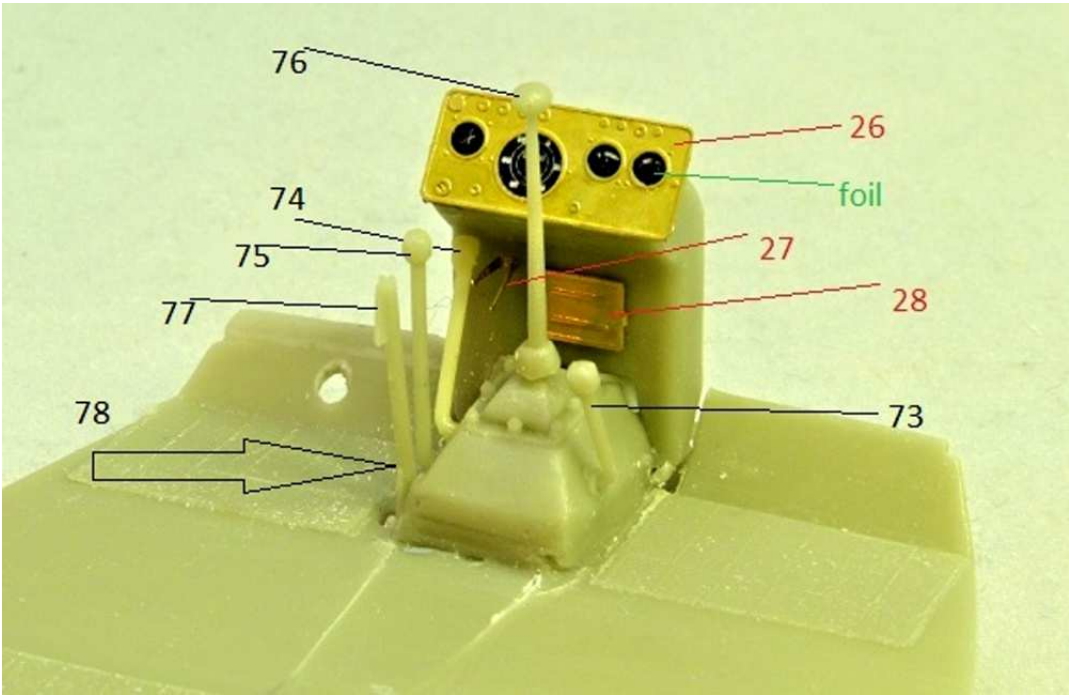
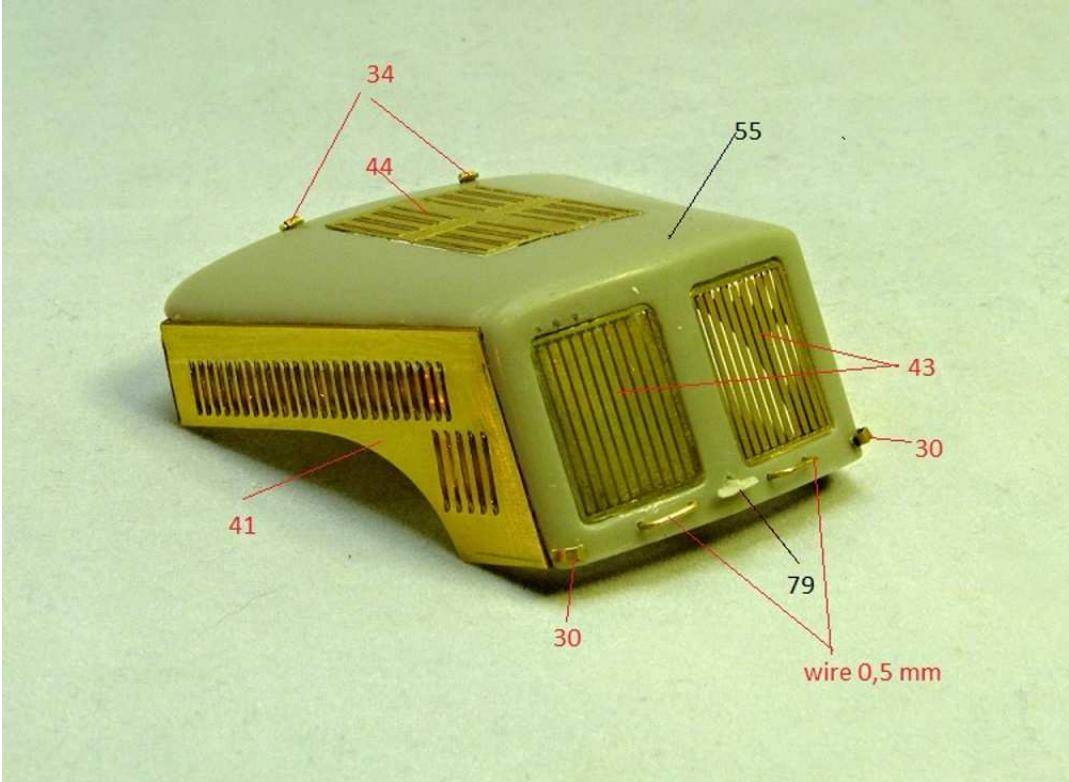

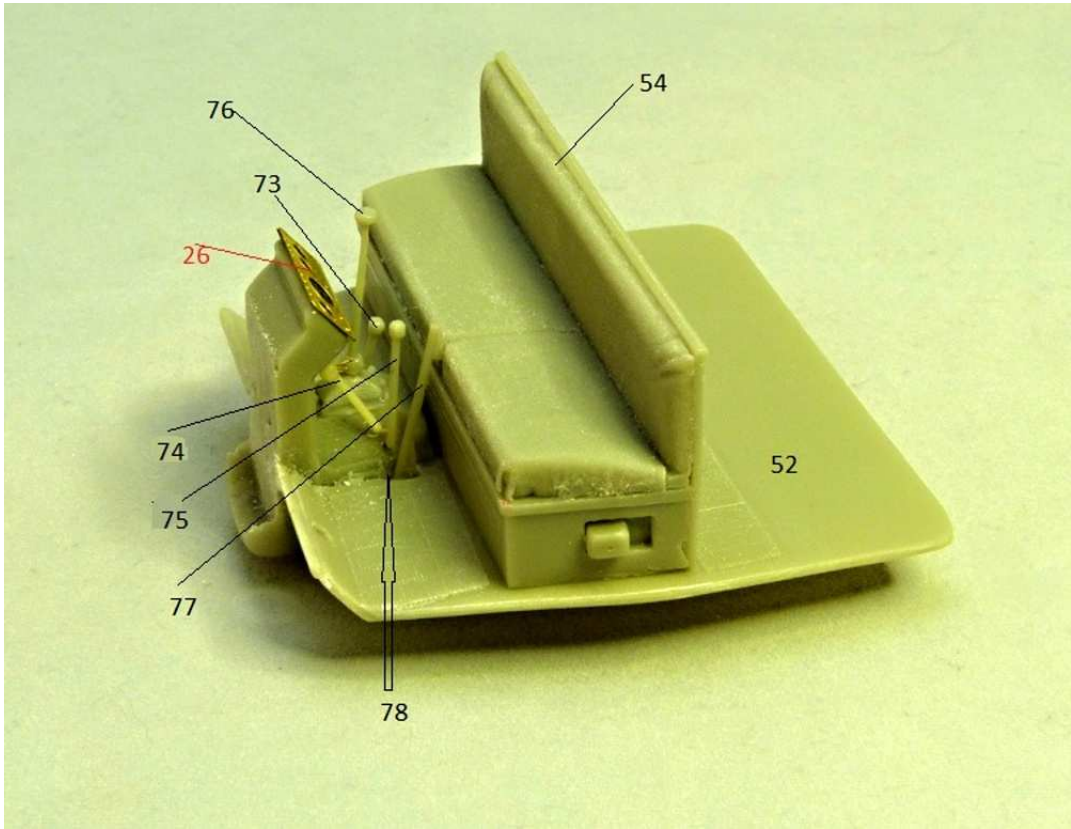
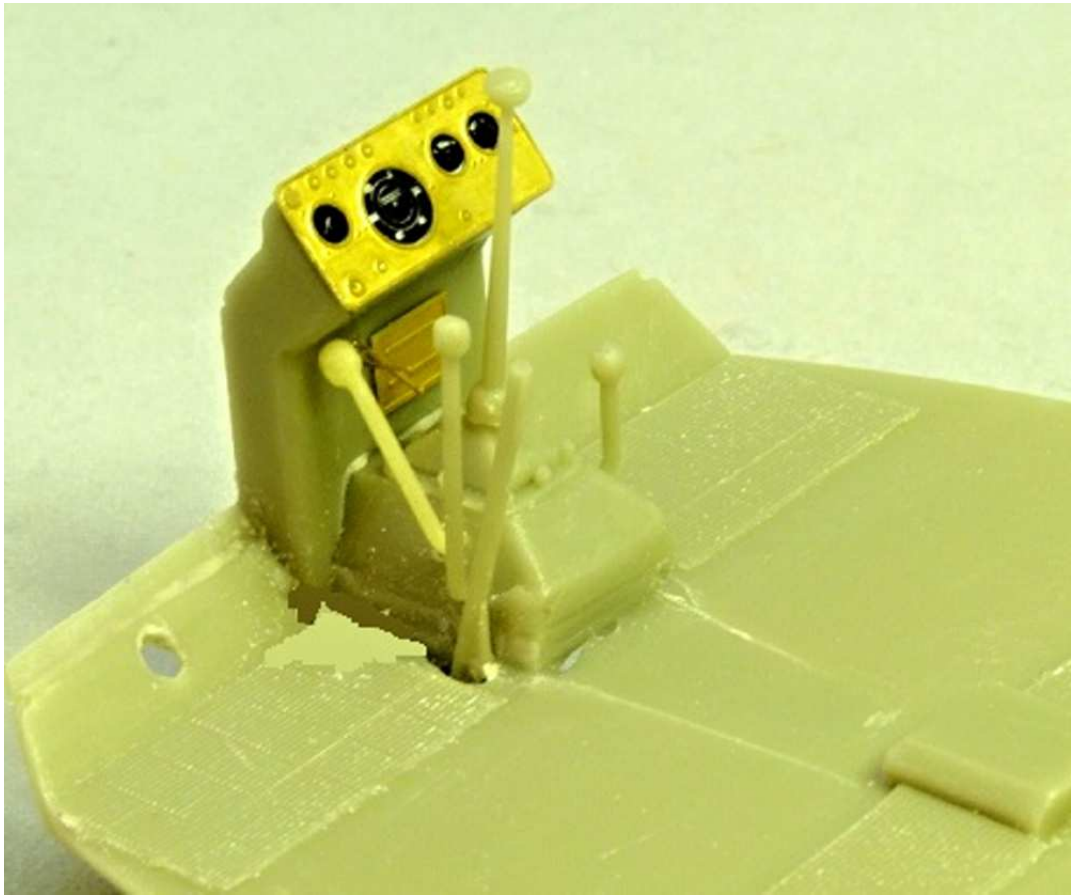

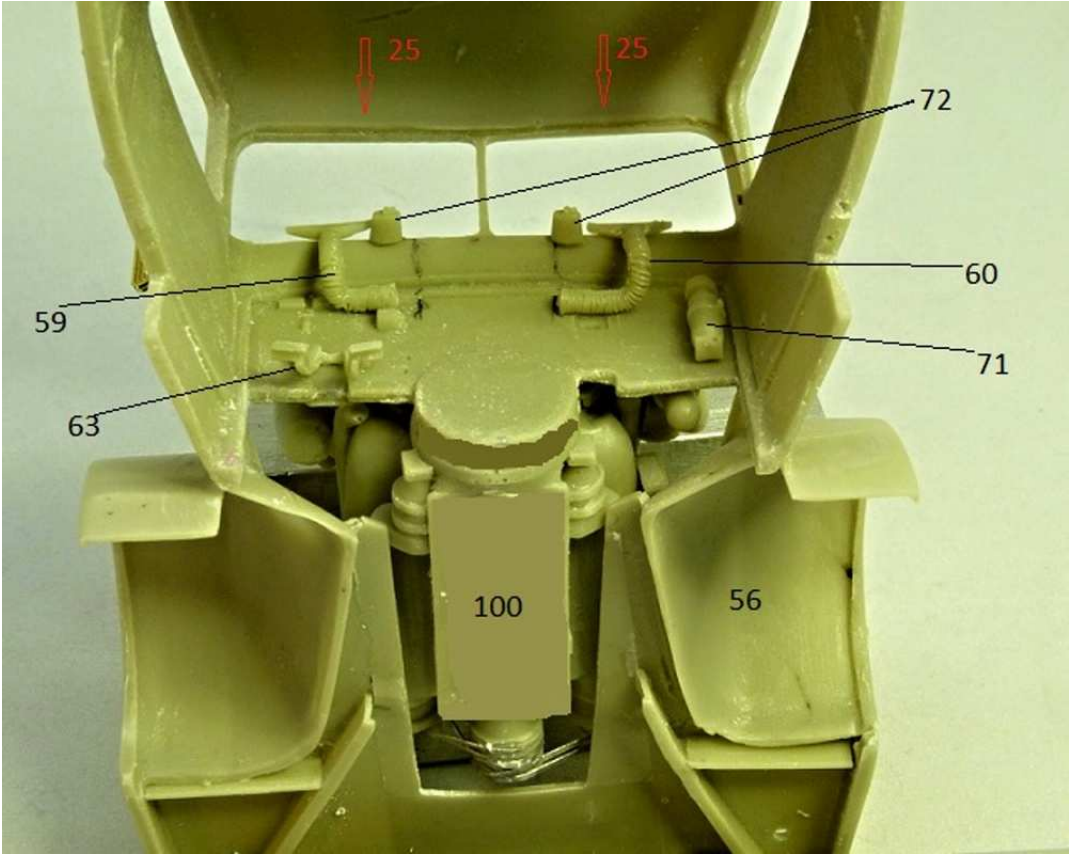

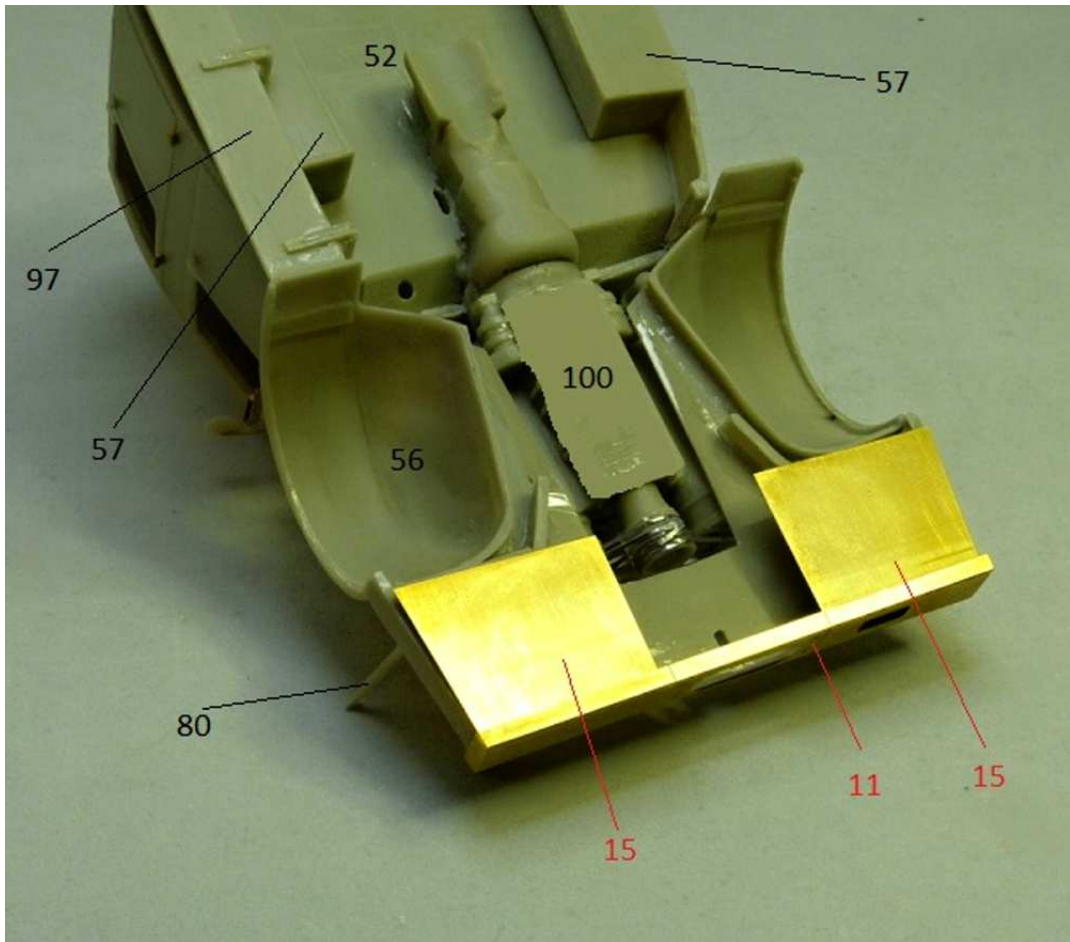
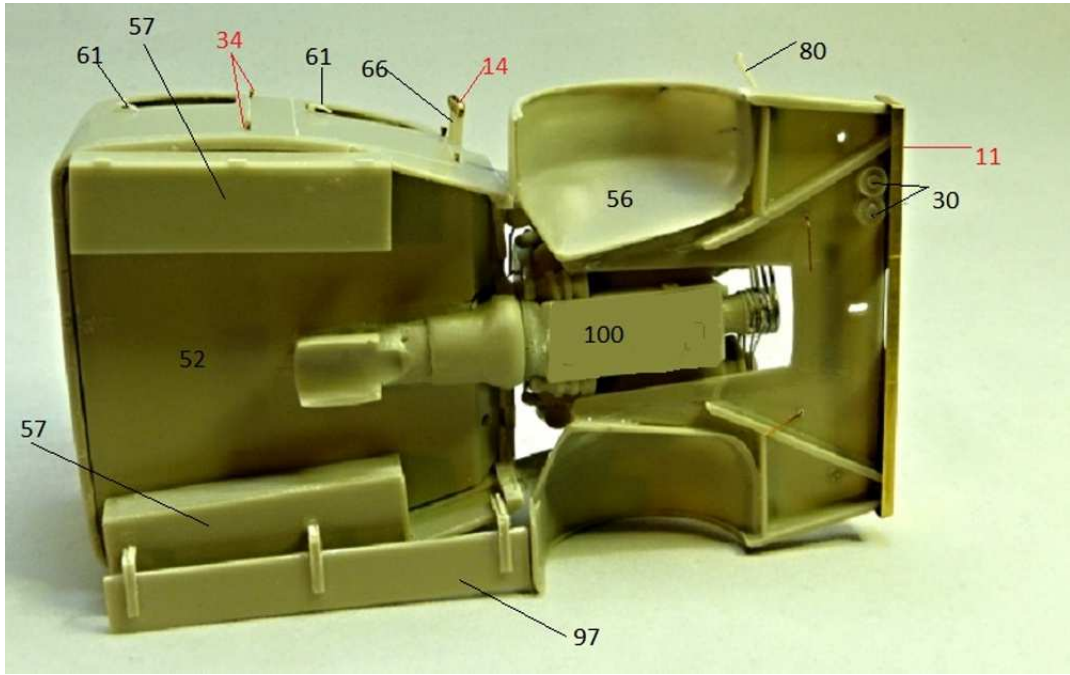

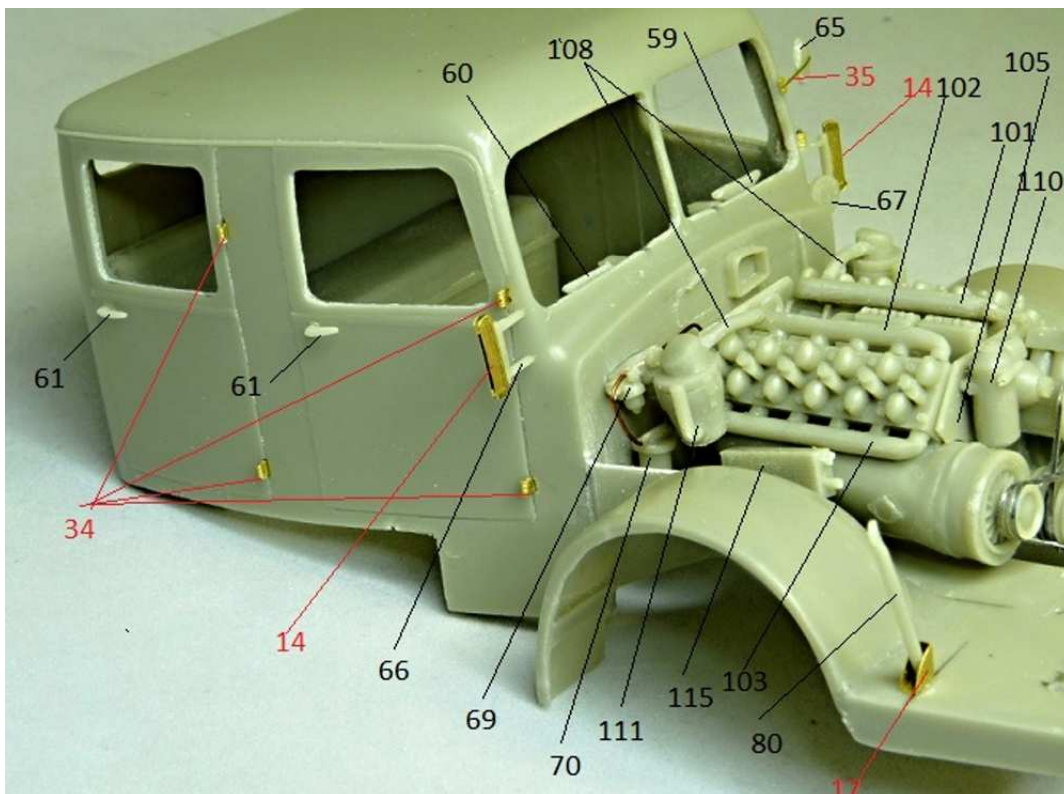
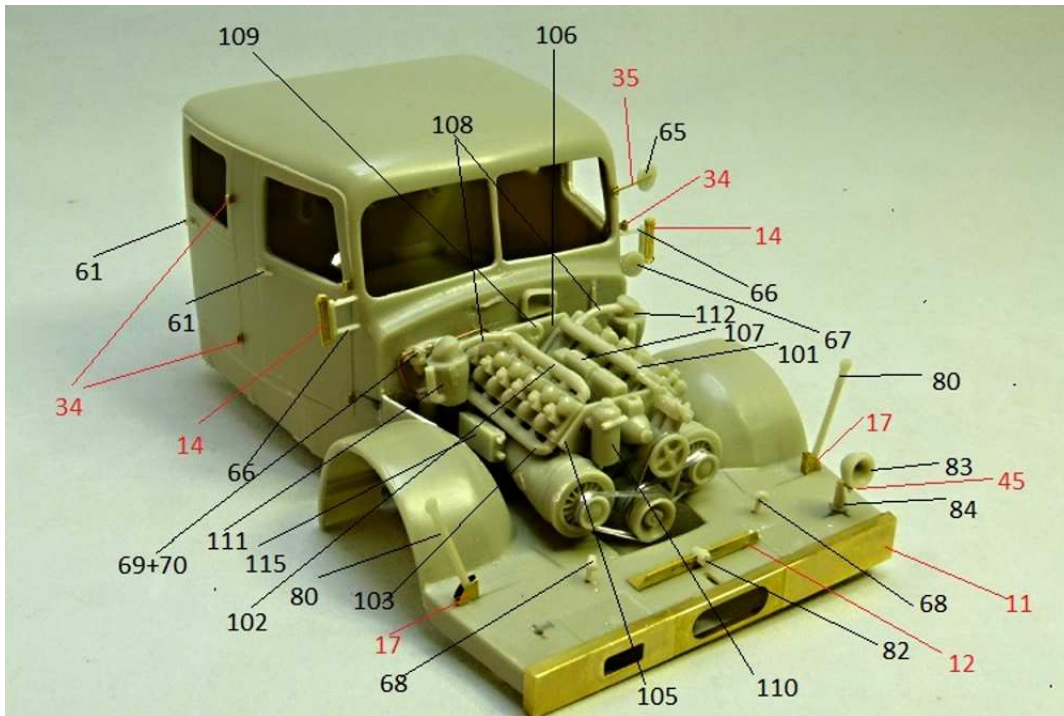

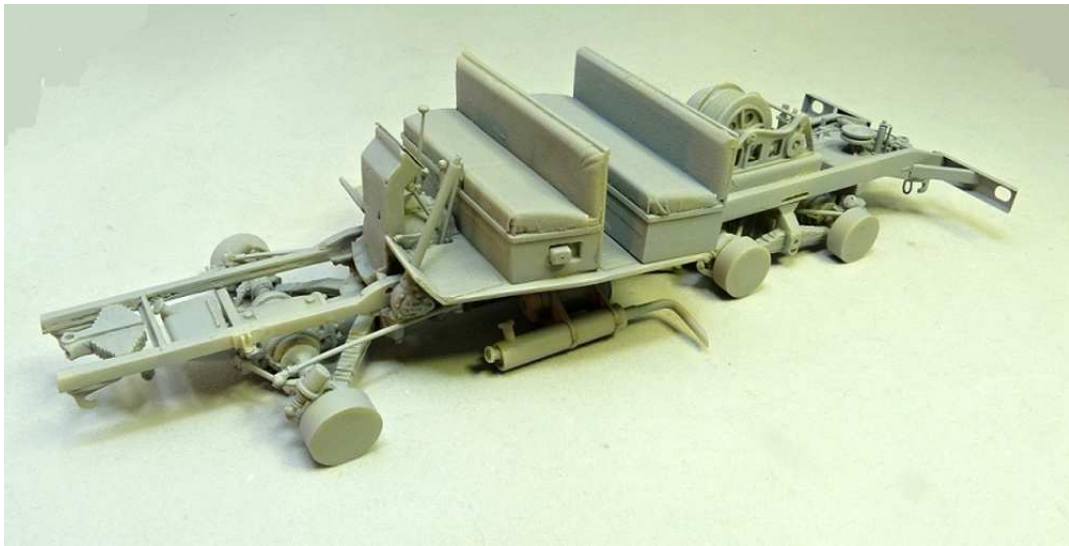



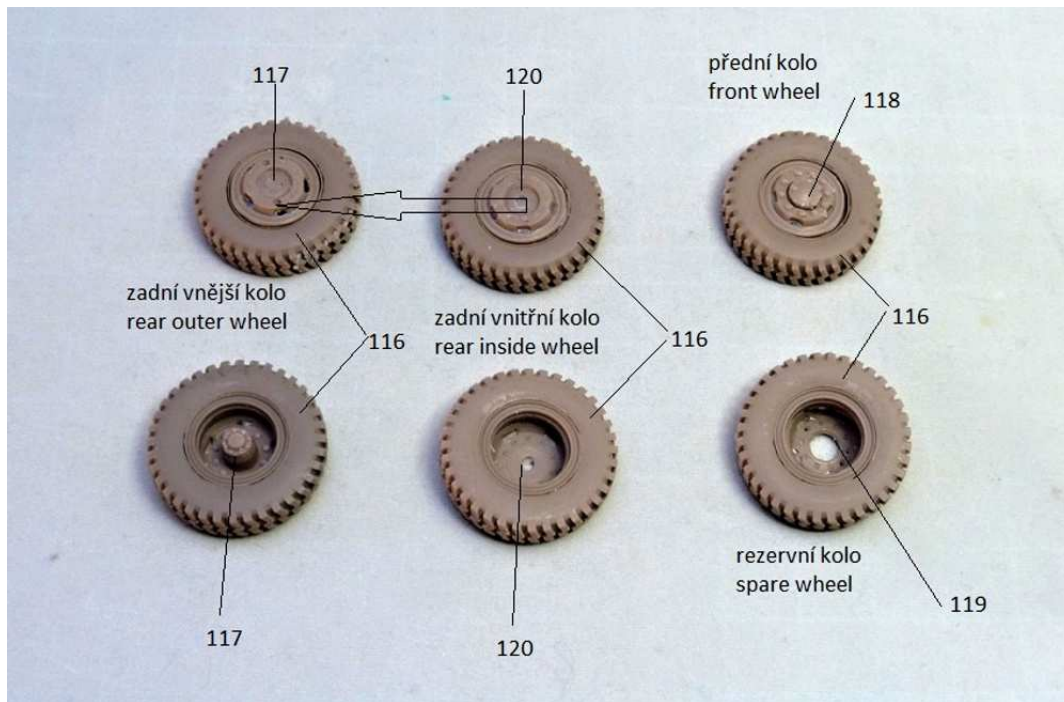



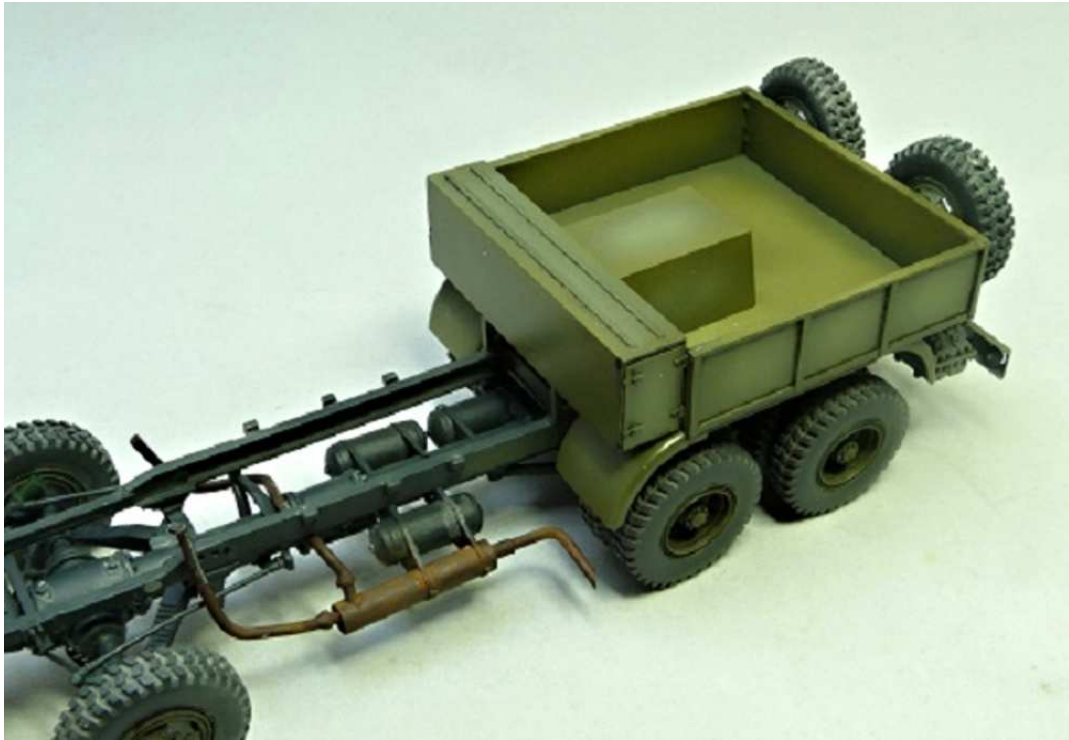







Československá státní automobilová doprava - ČSAD



Stavby Silnic a Železnic (restaurovaný veterán) - SSŽ

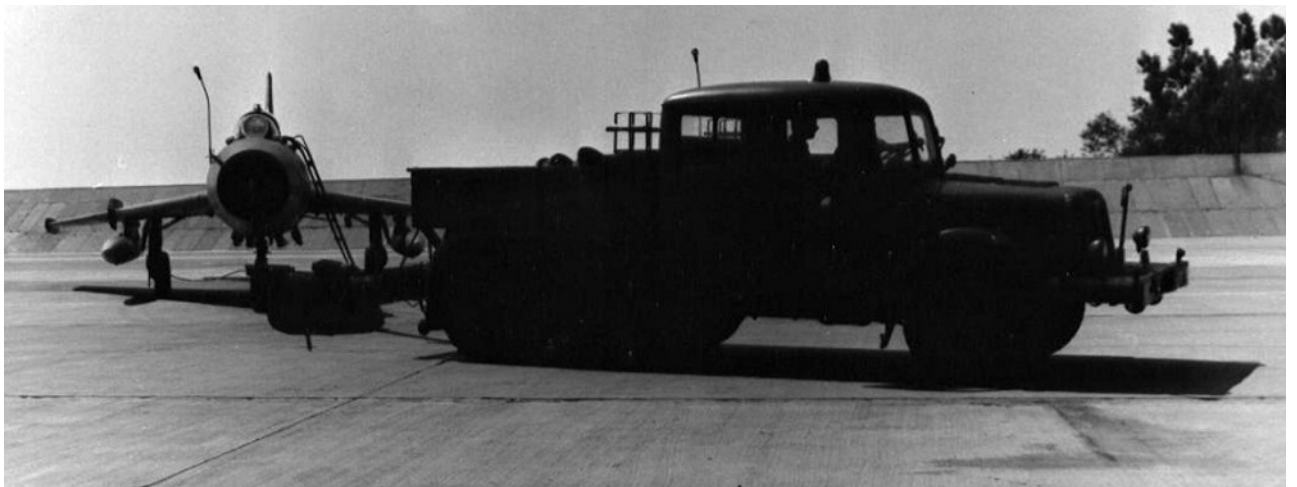

Československá lidová armáda - ČSLA



ČSLA



Wojsko Polske



Volksarmee DDR- VA



Deutsche Raichsbahn - DR

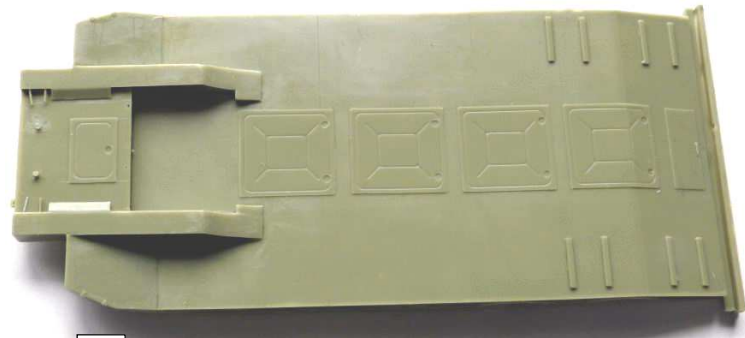

1

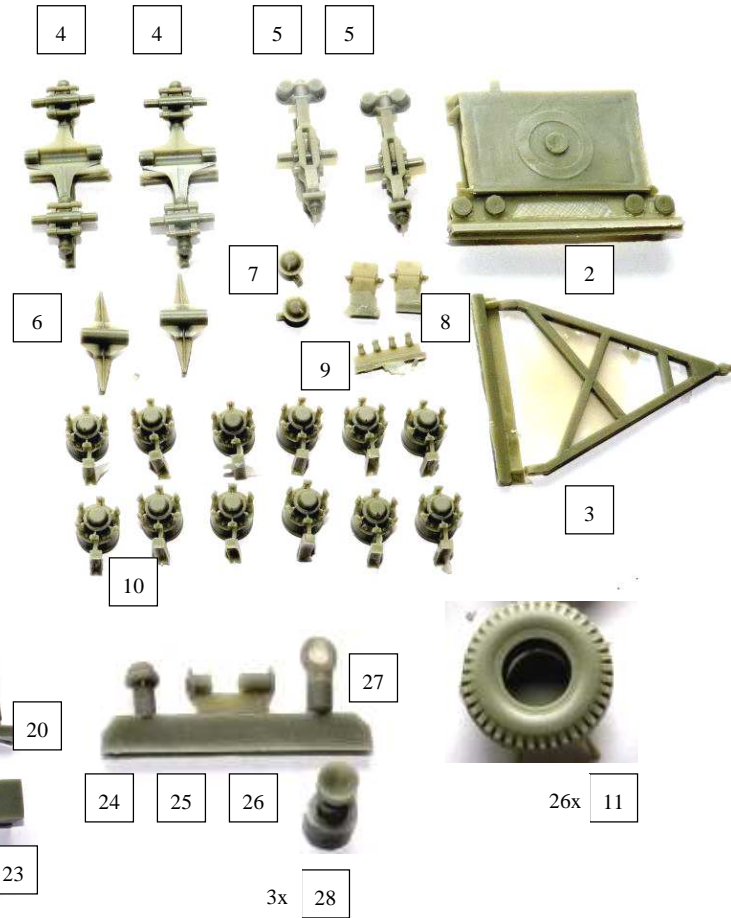

4

4

5

5

2

7

6

8

9

3

10

18

15

13

17

12

13

16

19

27

20



26x 11

12

14

29

24

25

26

21

22

23

3x 28

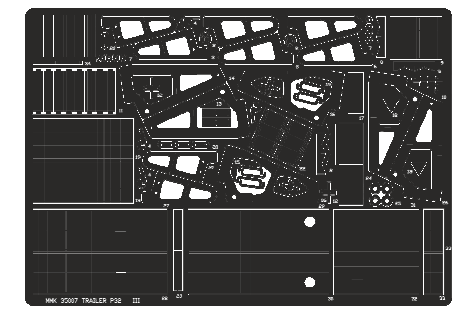
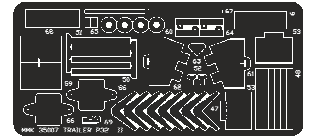
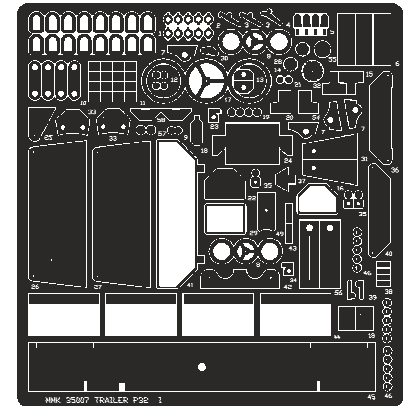

- RESIN PARTS



- PHOTO-ETCHED PARTS I, II



- PHOTO-ETCHED PARTS III

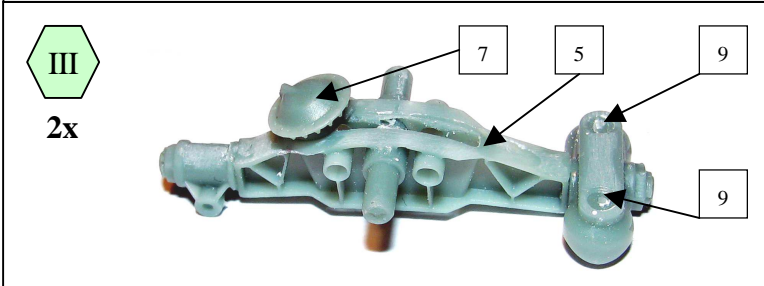
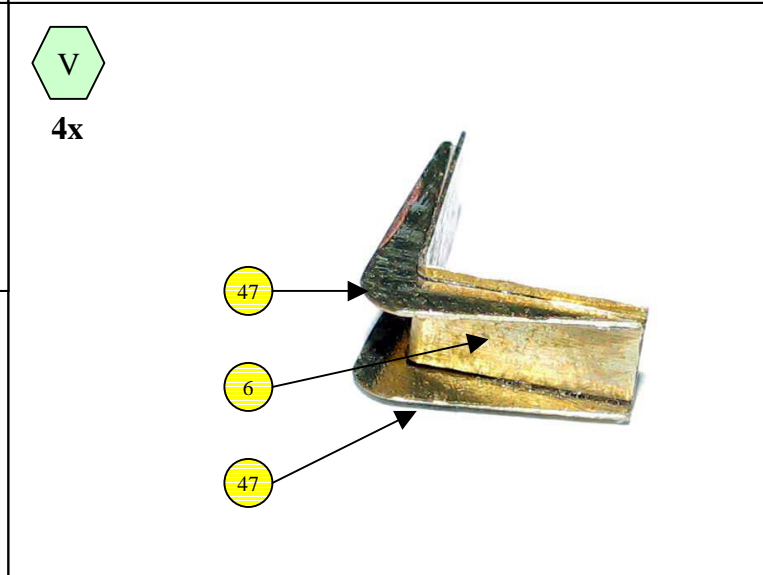
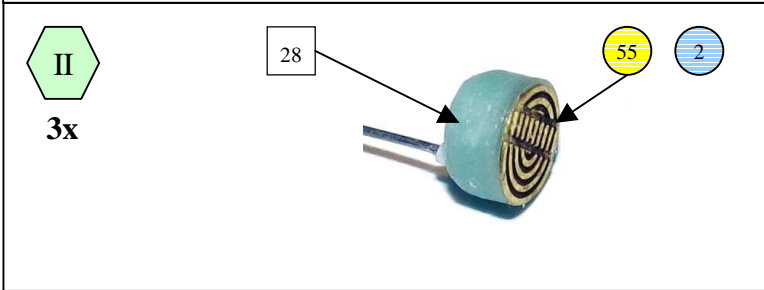
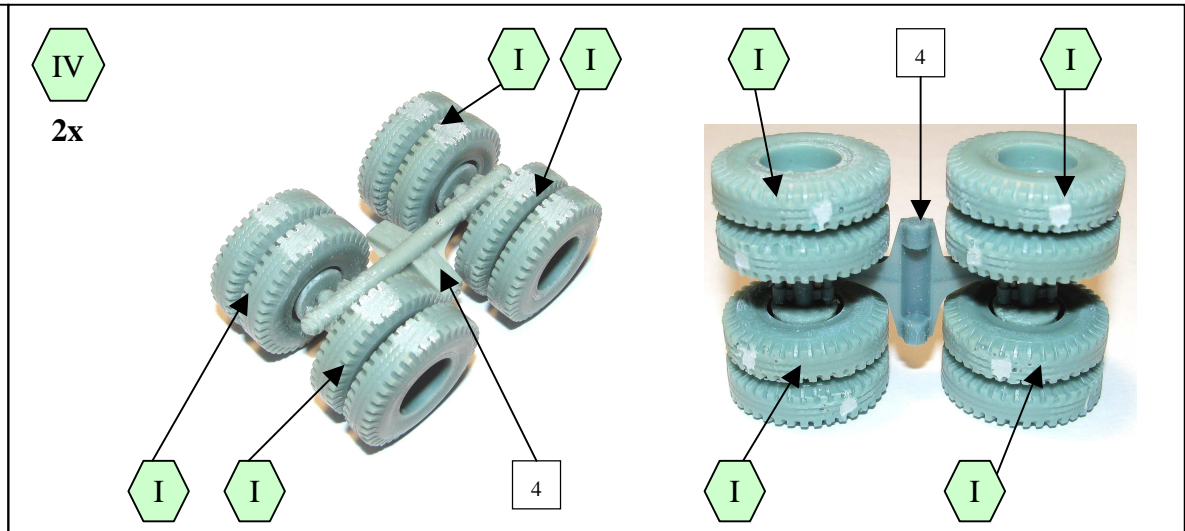
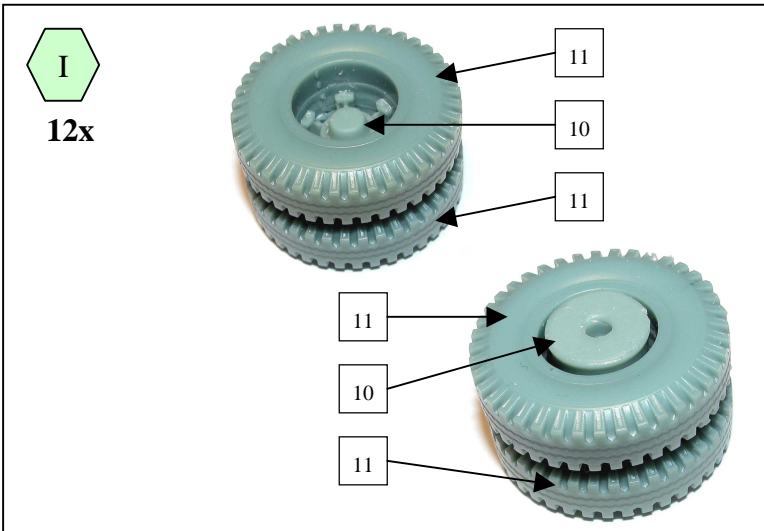

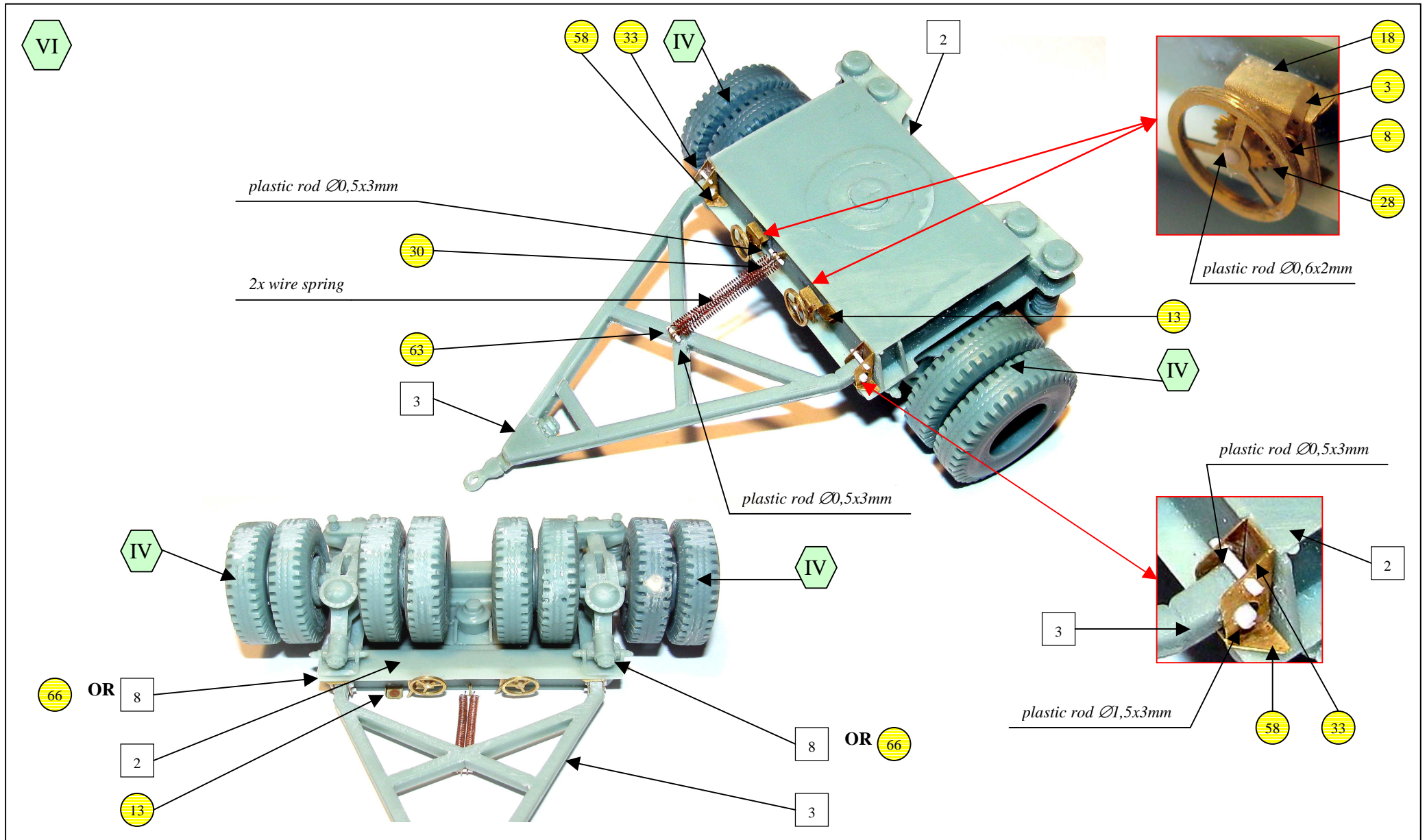

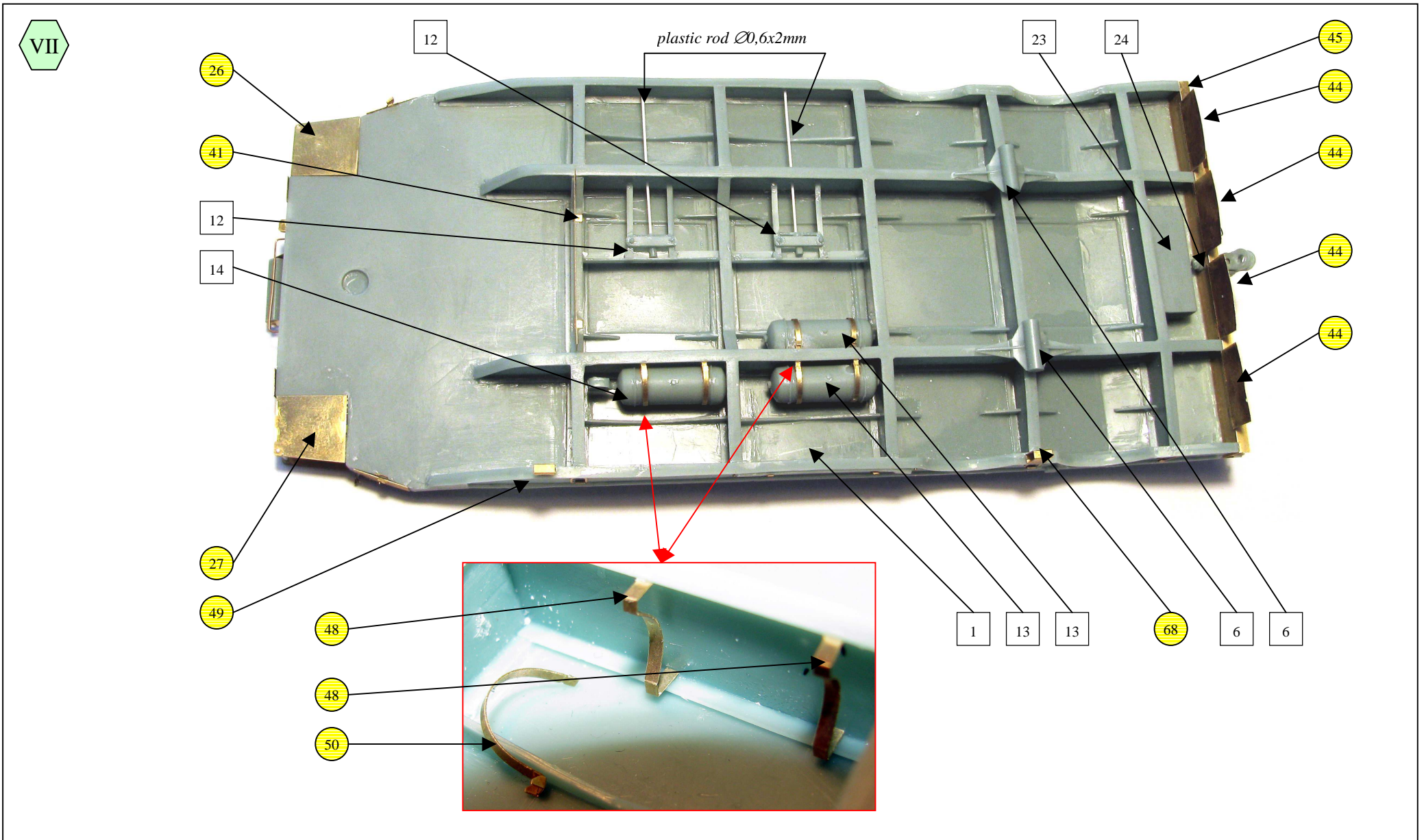
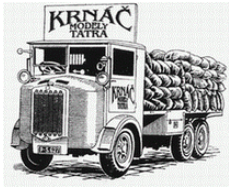



VIII

left side

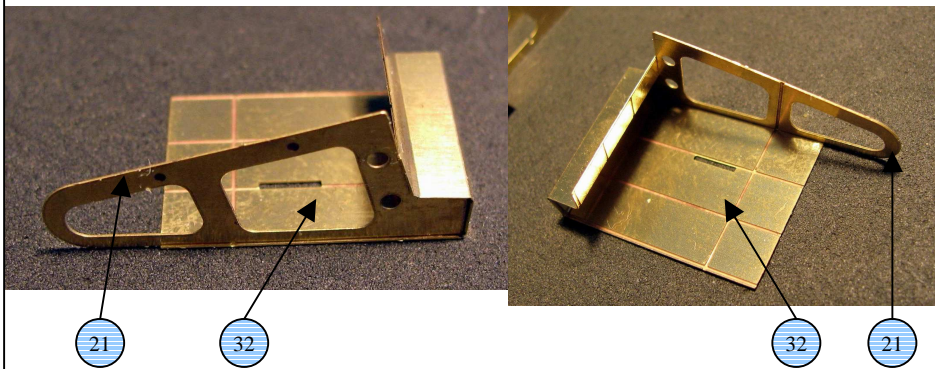
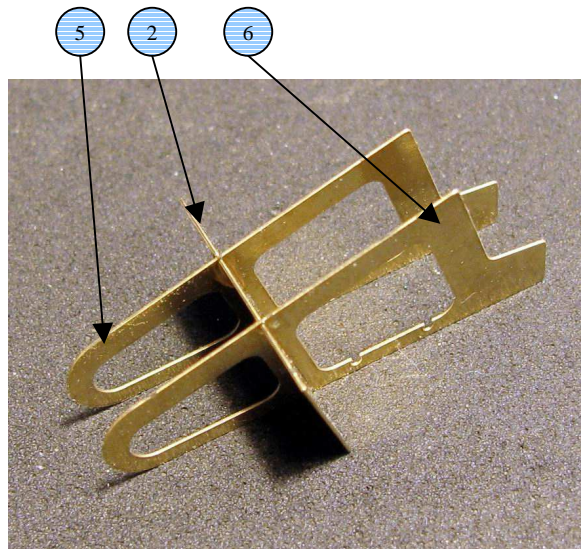

right side

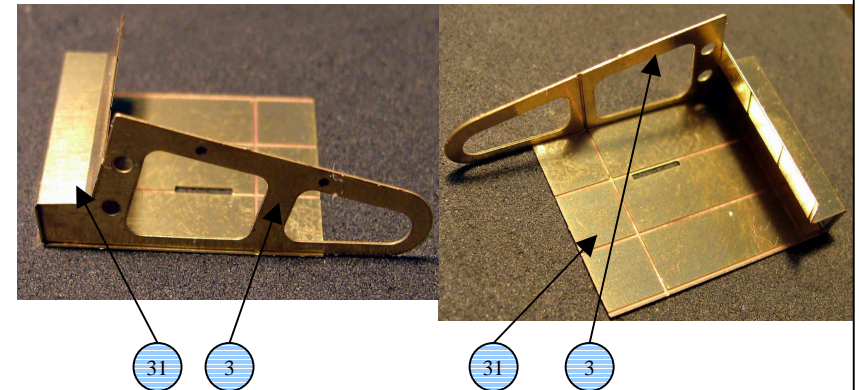
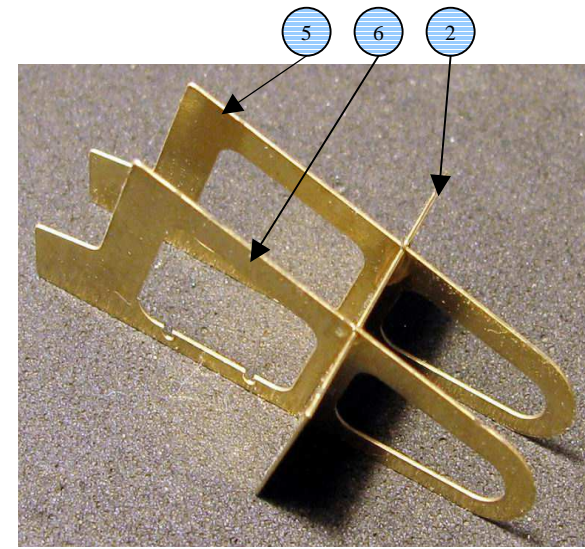

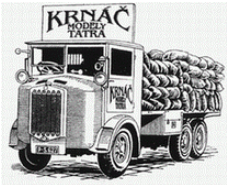

VIII

left side

right side

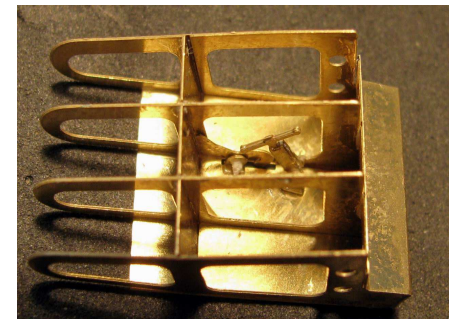
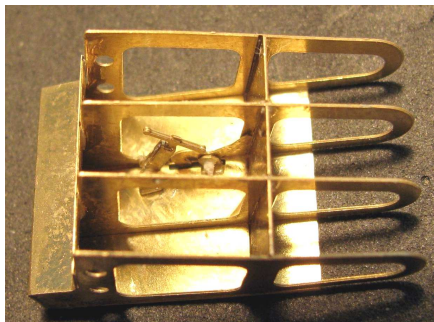
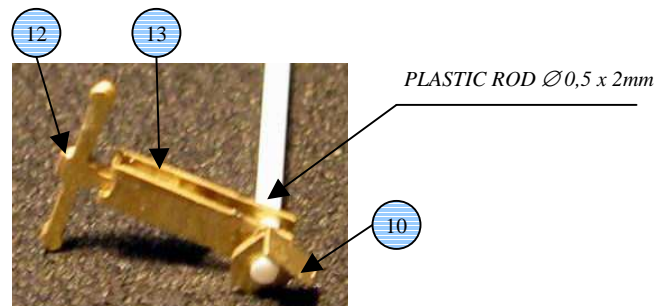
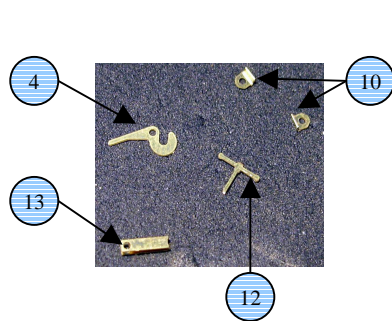
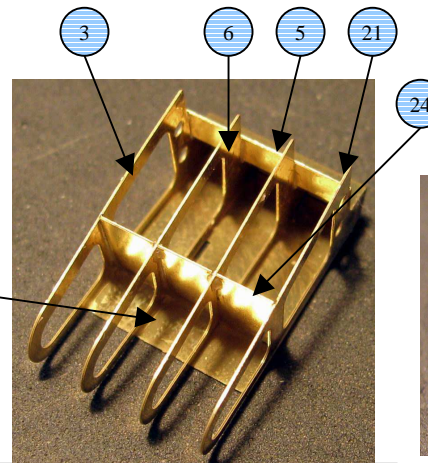
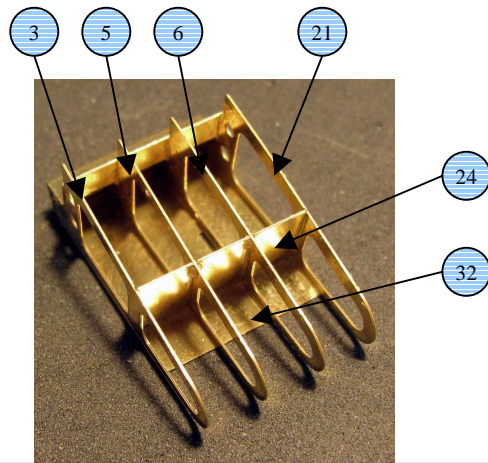

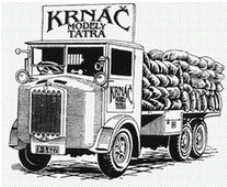

VIII

left side

right side

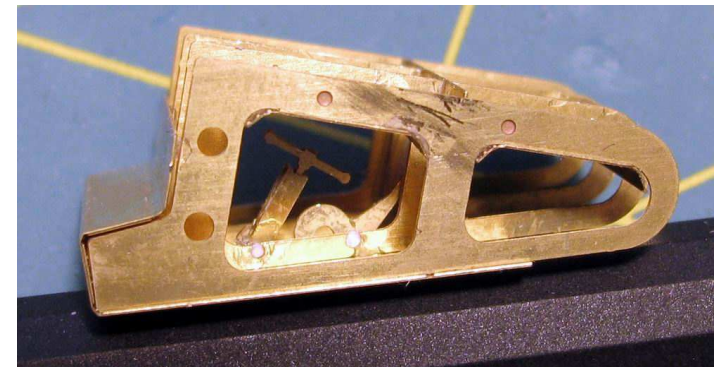
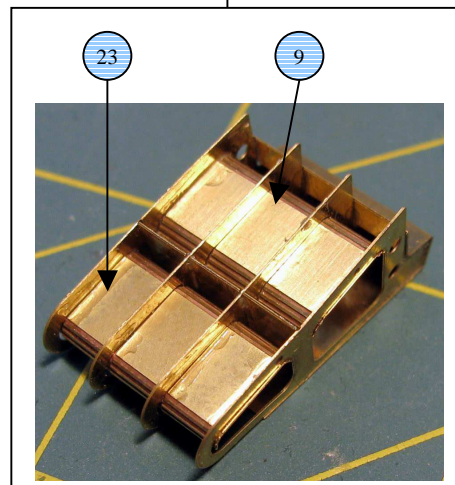
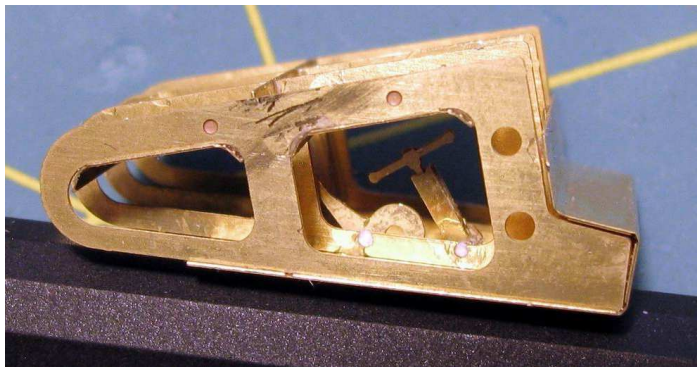
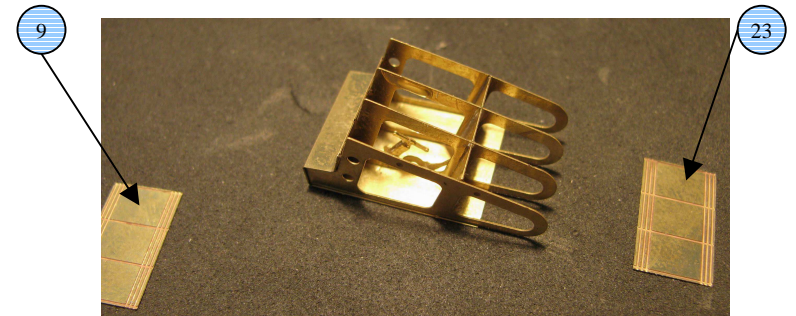
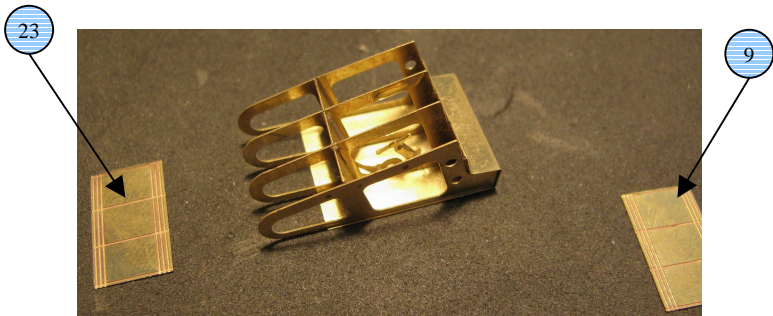



VIII

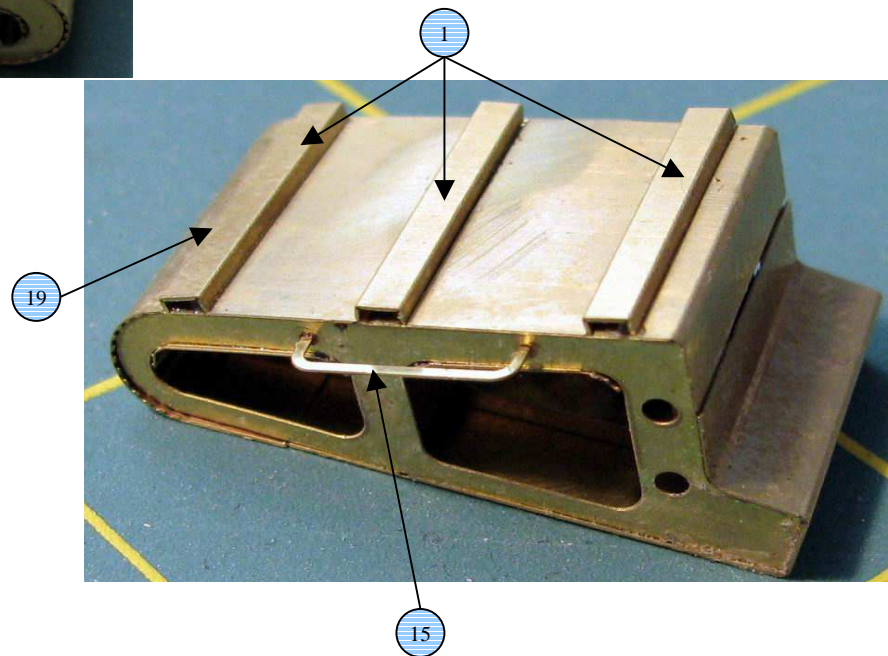
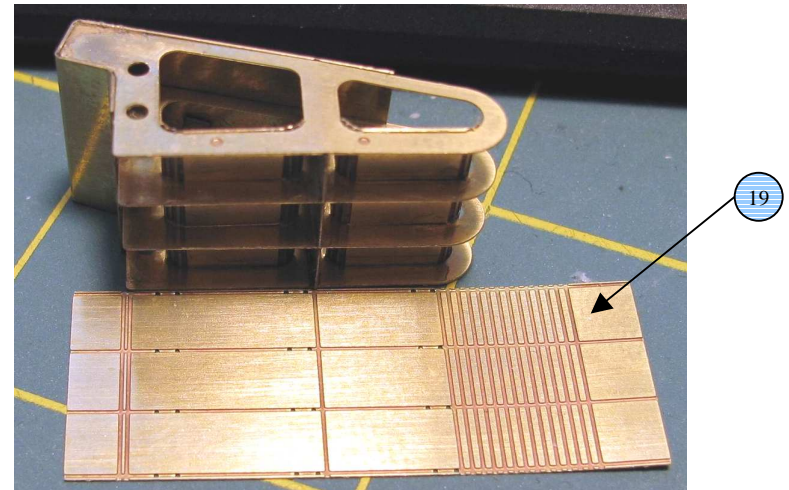
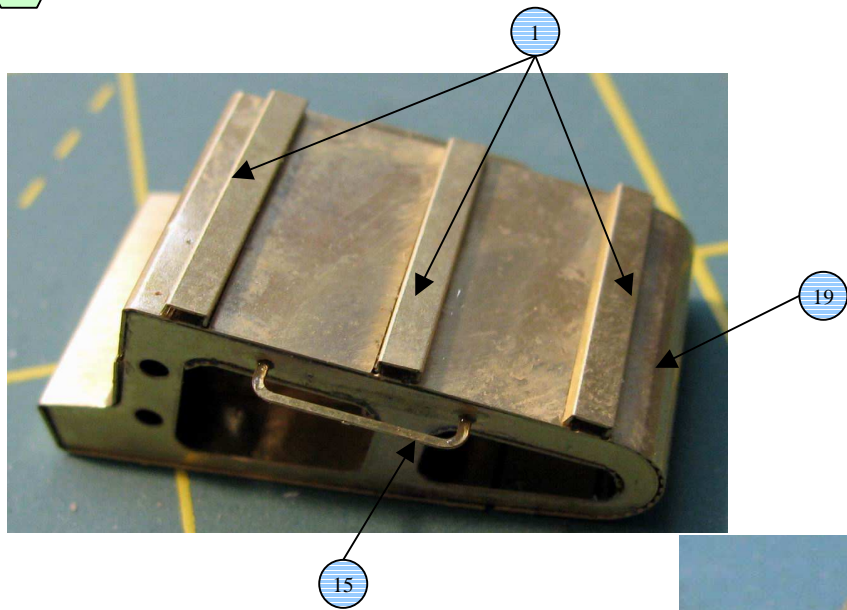

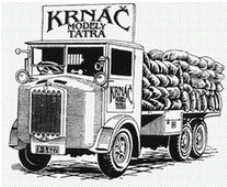

VIII

left side

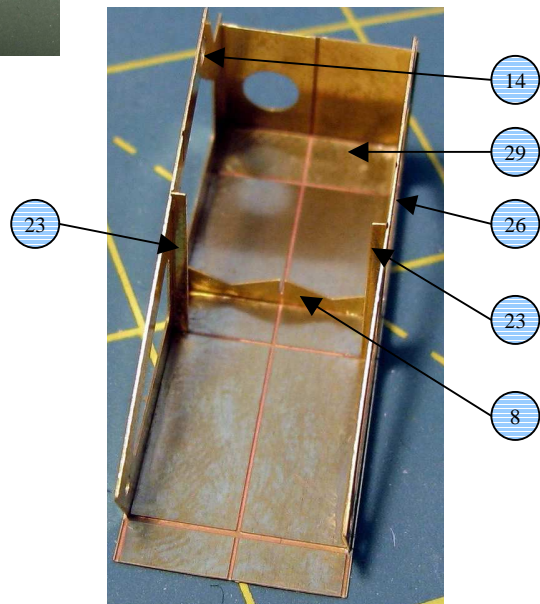
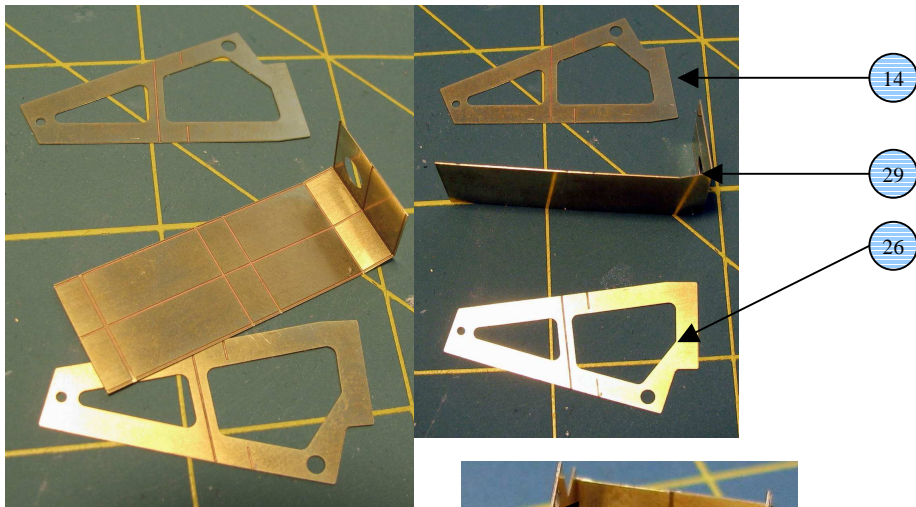

right side

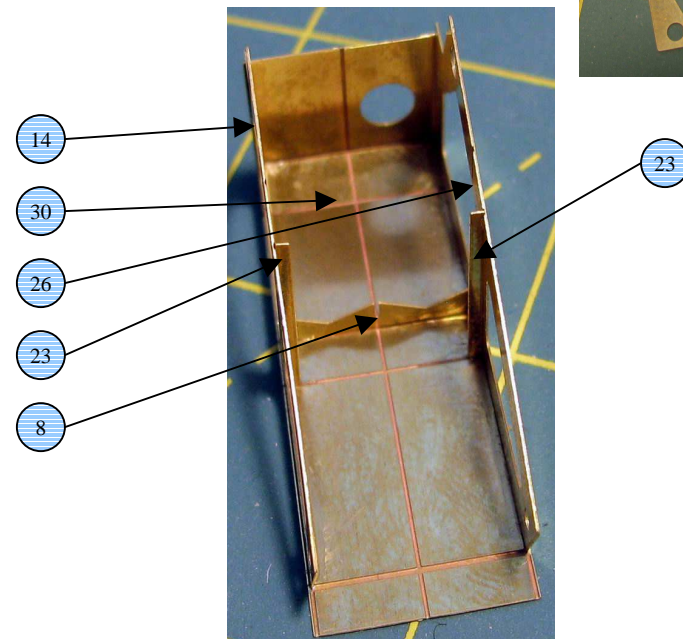
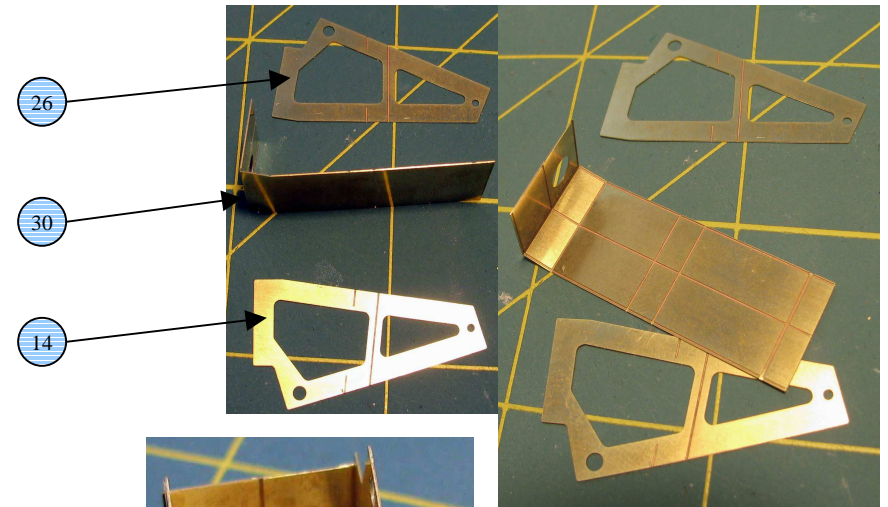



VIII

left side

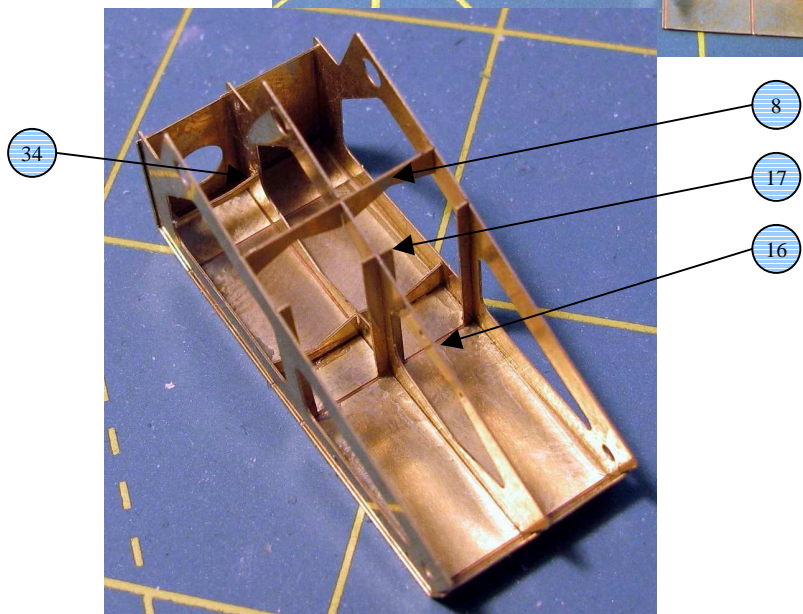
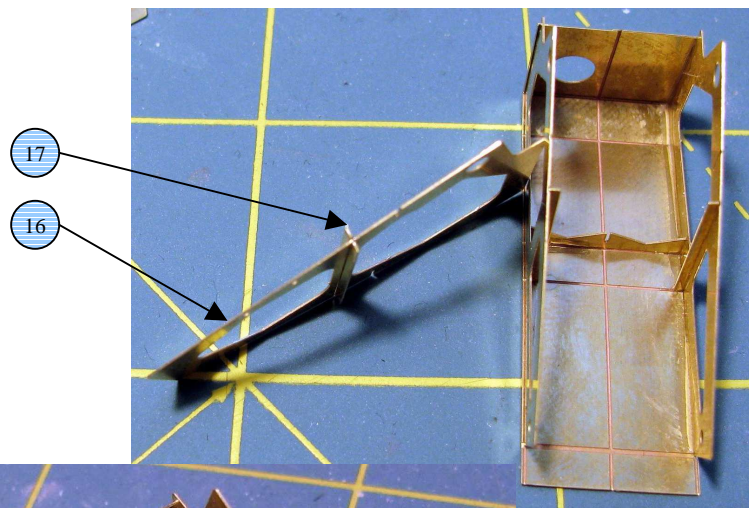

right side

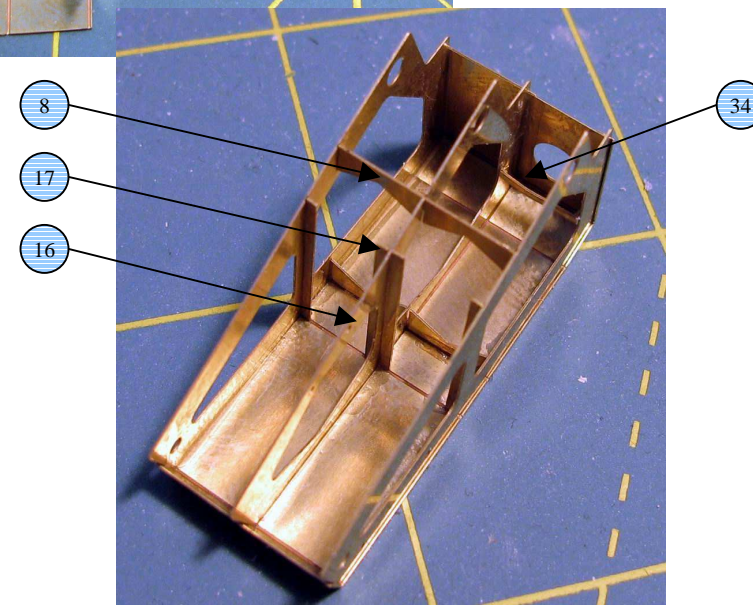
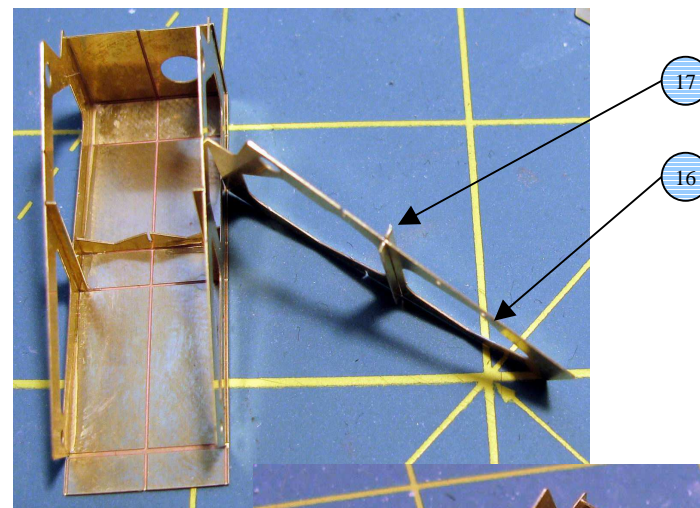



VIII

left side

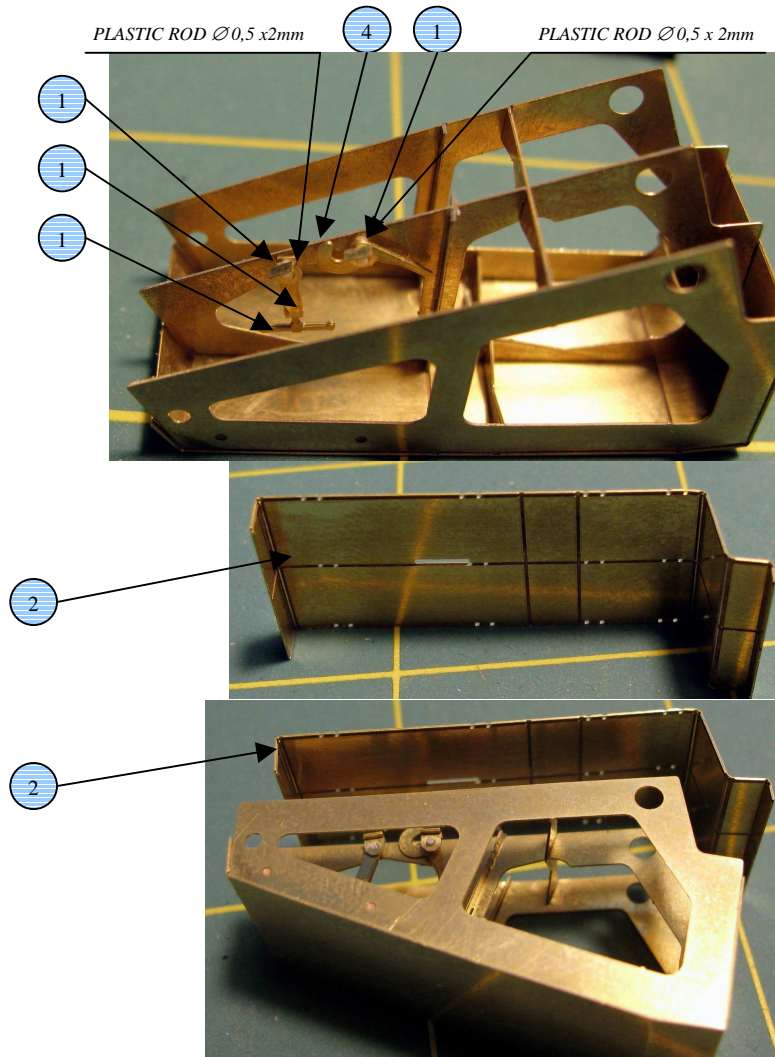

right side

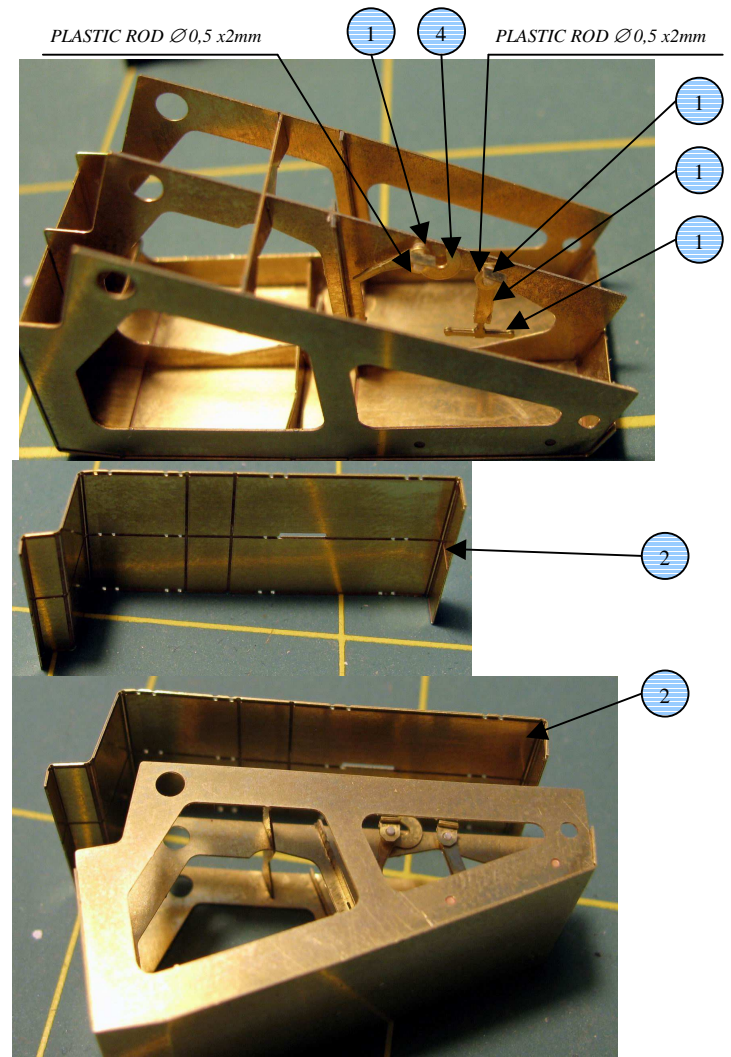

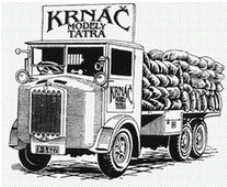

VIII

left side

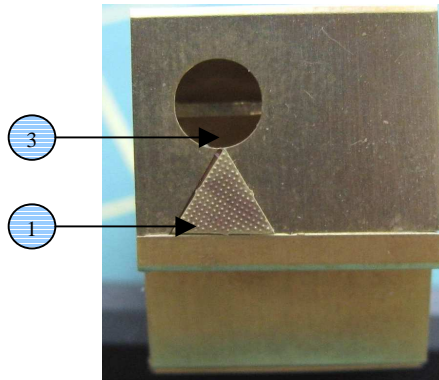
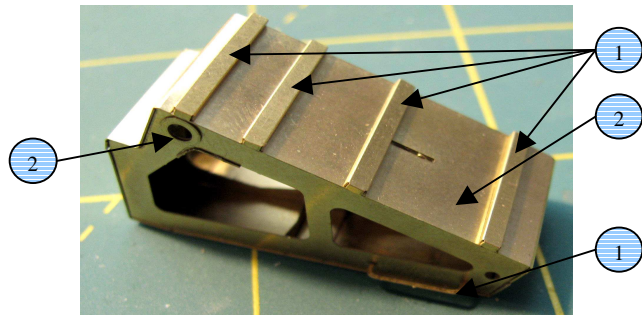

right side

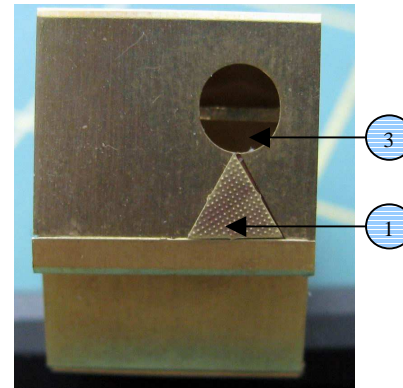
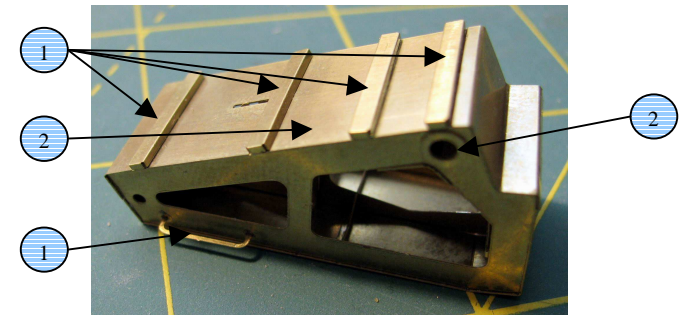

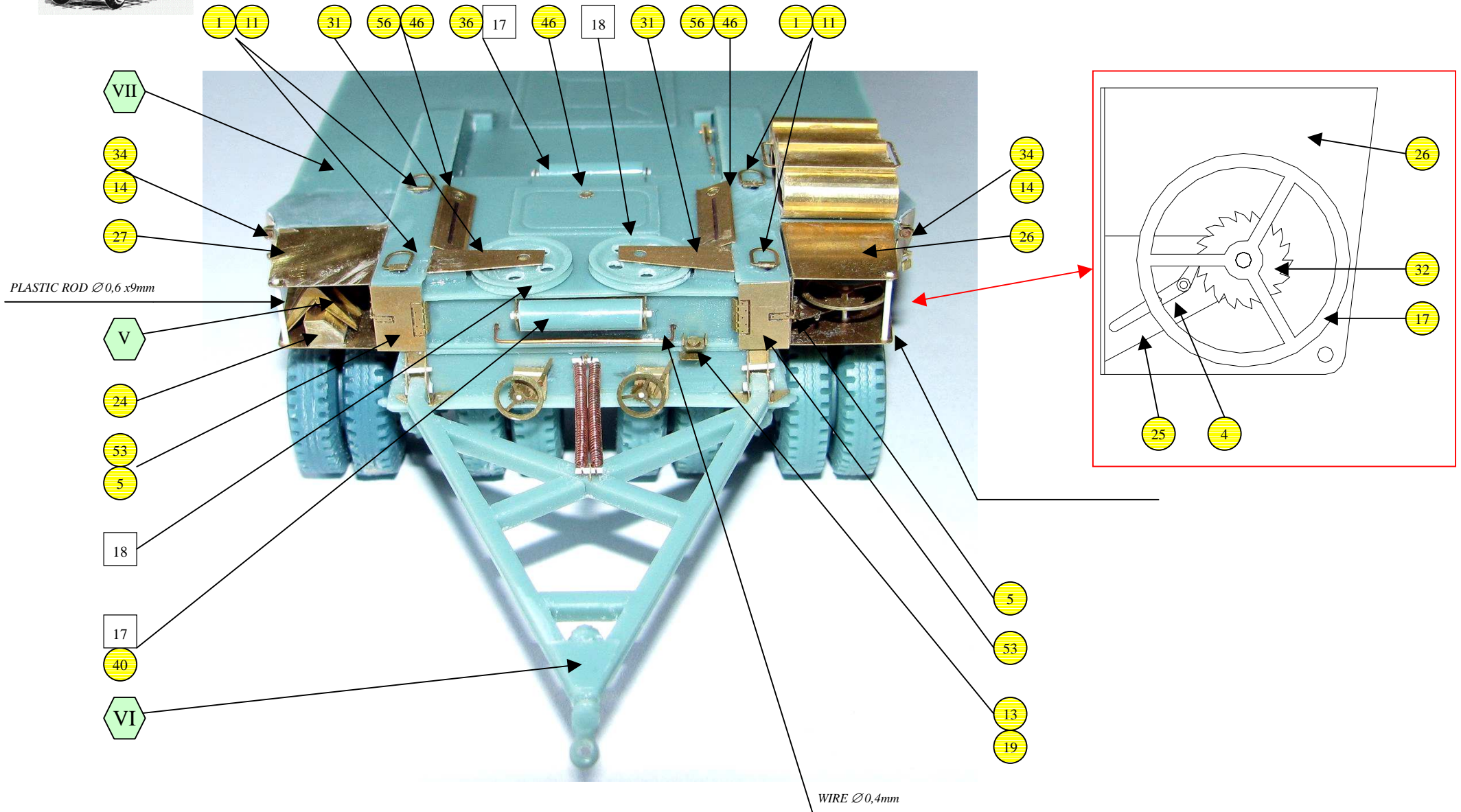



TRANSPORT CONFIGURATION

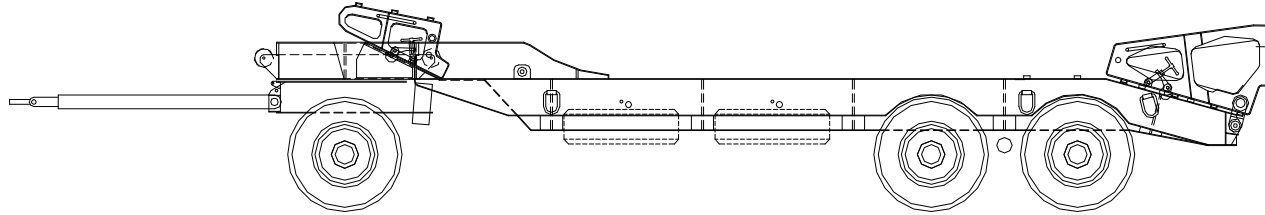

LOADING CONFIGURATION

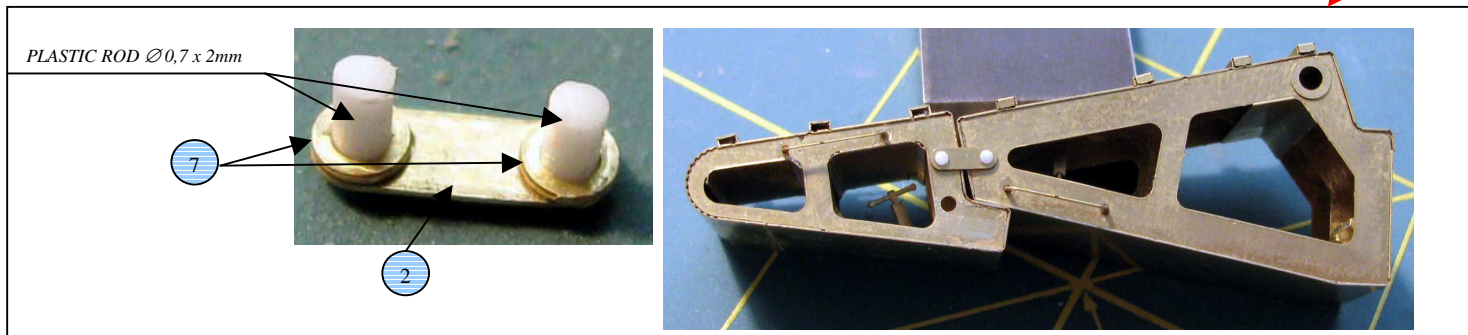
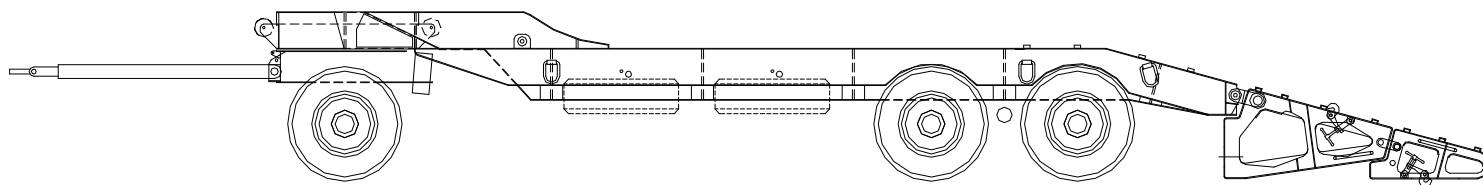

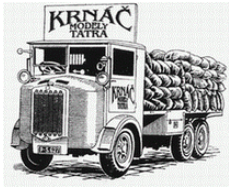

Podvalník P 32 1/35 35058

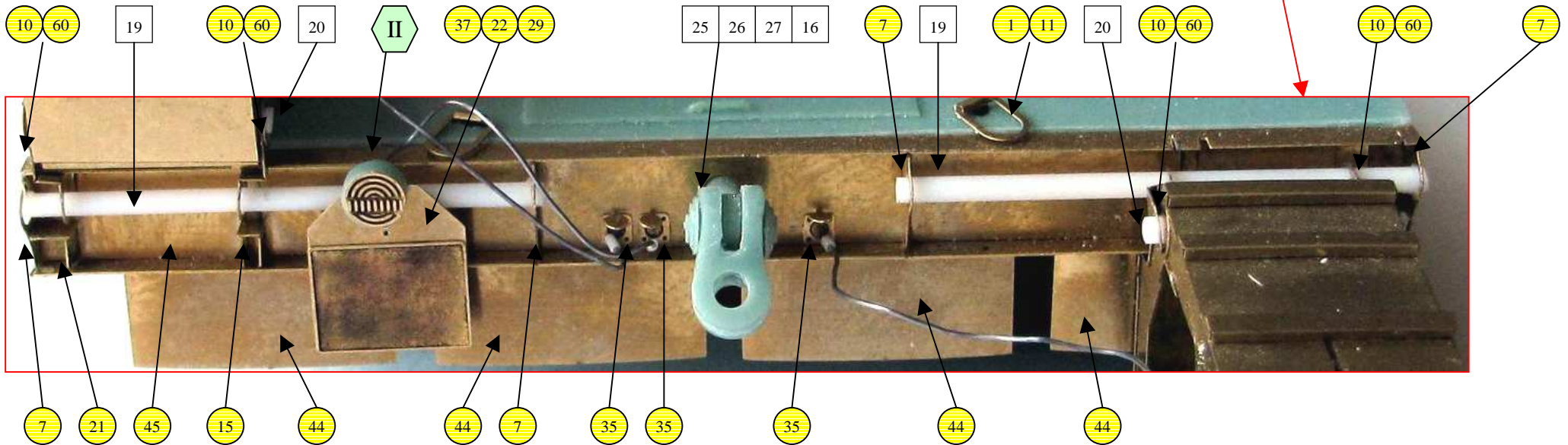
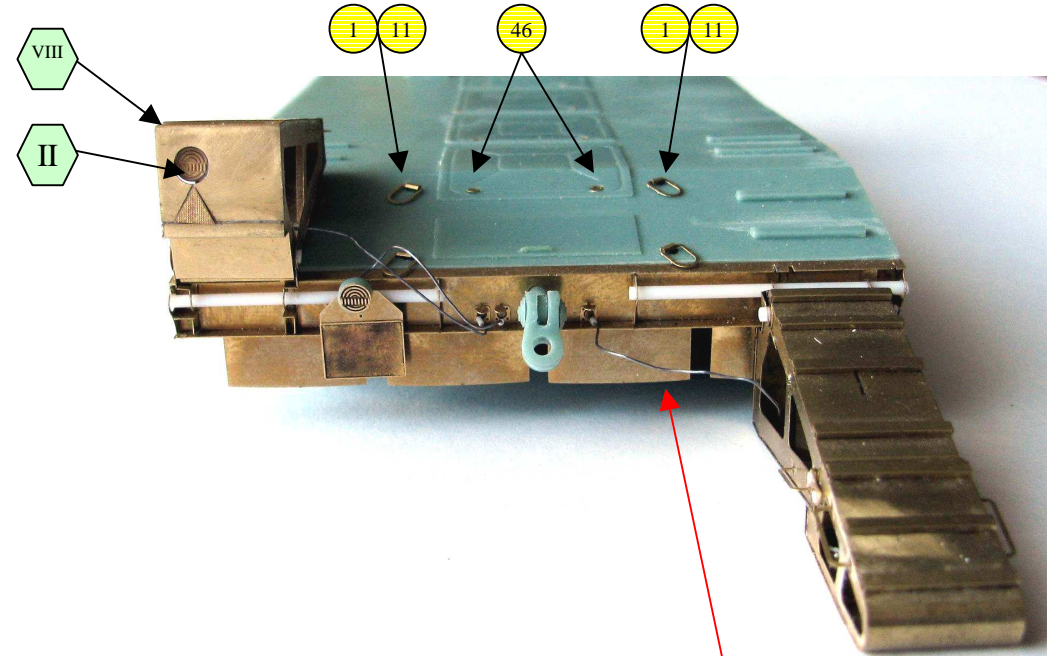
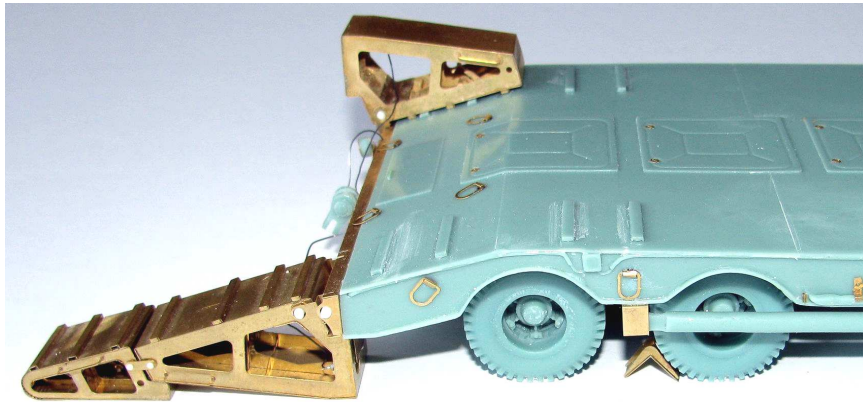

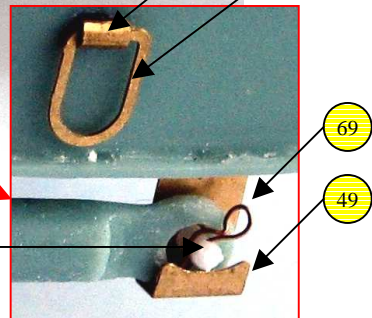
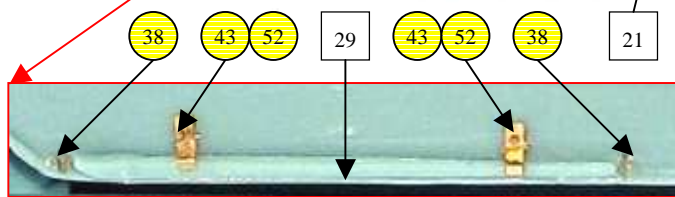
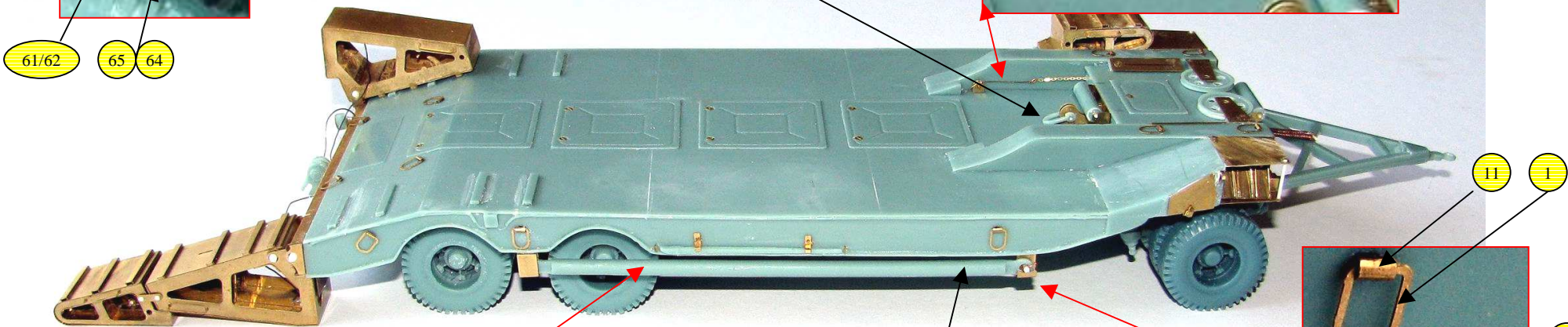
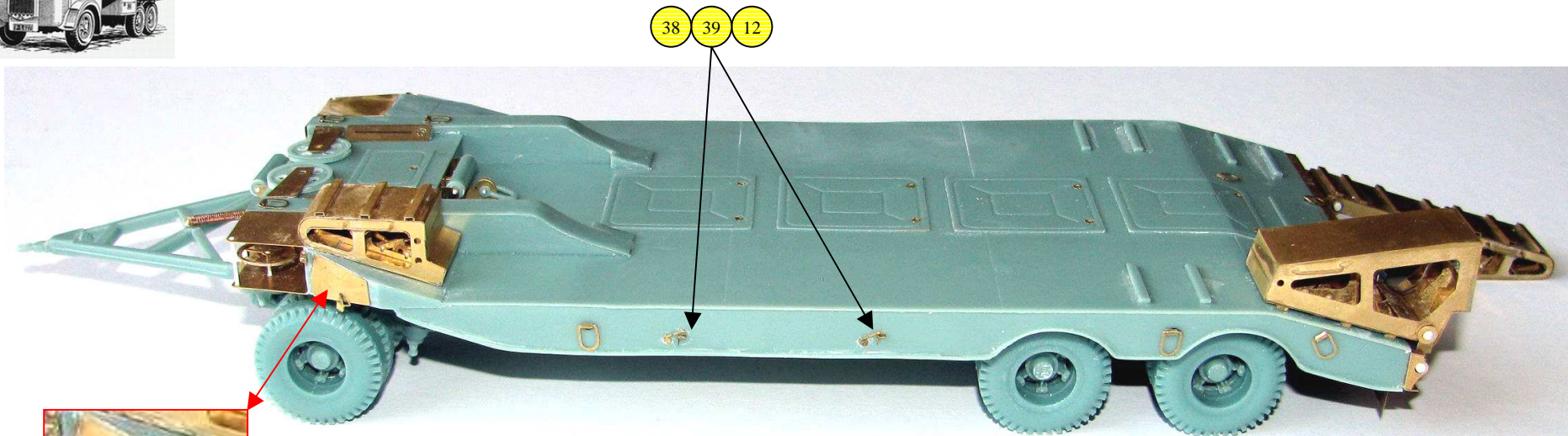

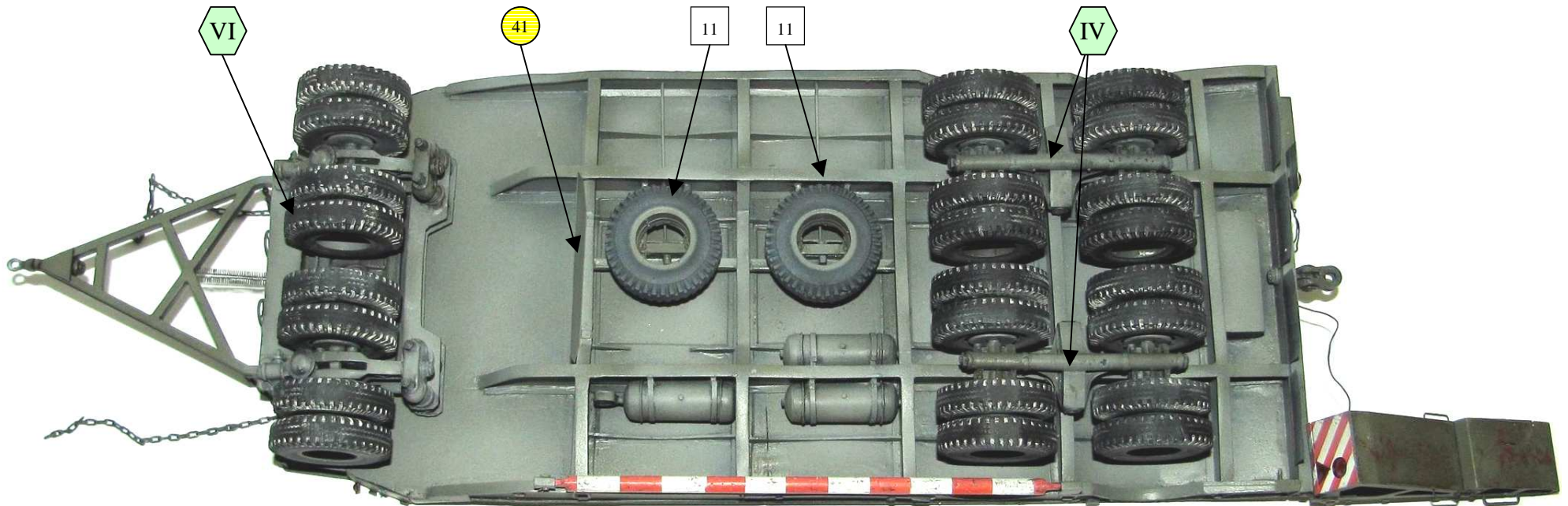



Podvalník P 32

1/35

35058

18/19





Podvalník P 32

1/35

35058

19/19

