

TL-4 OPLEN

1/35

35060

1/30

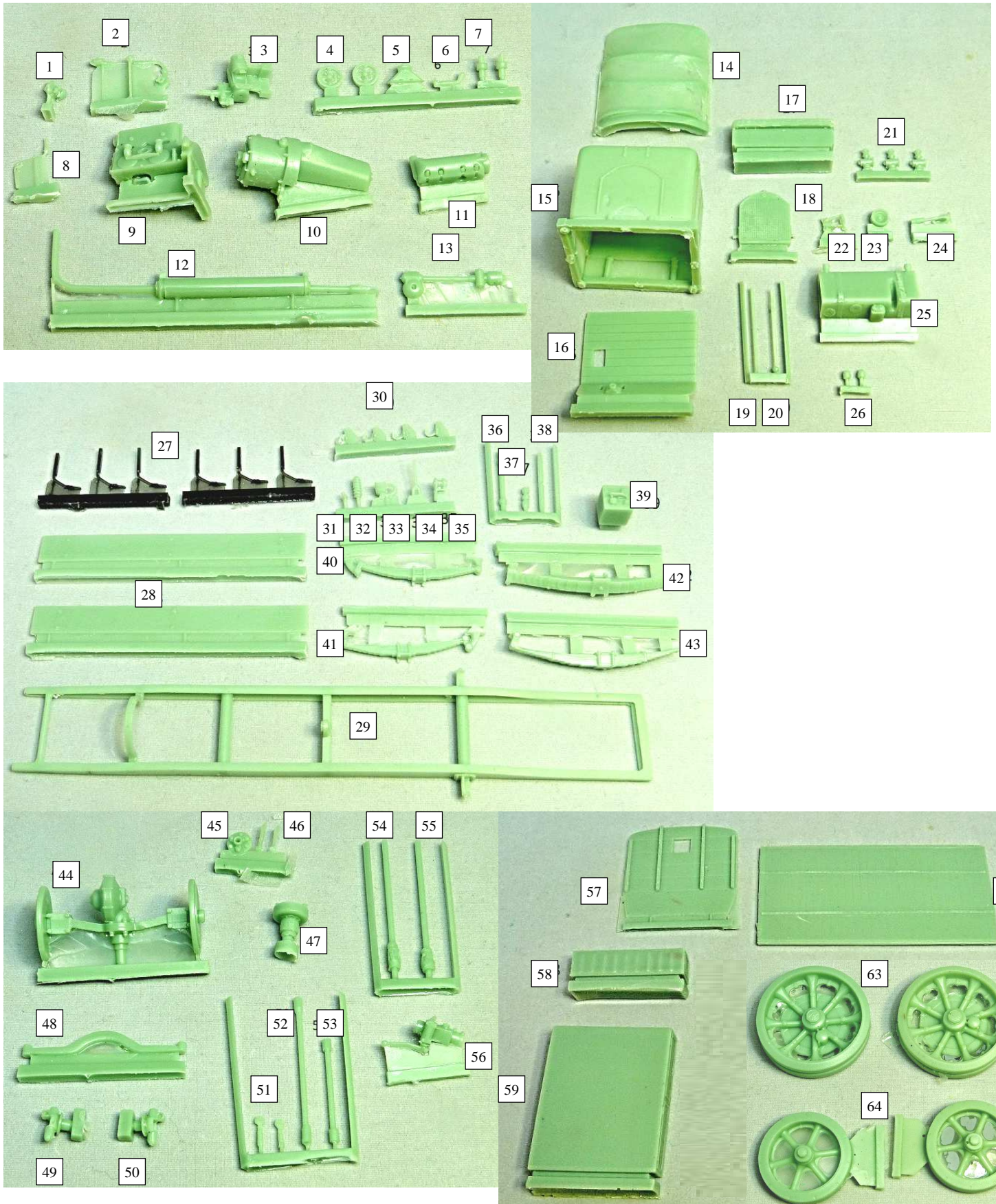

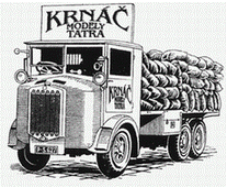

65

65

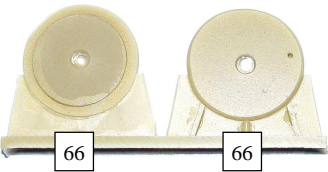

66

66



67



68

69

70

71



72



73

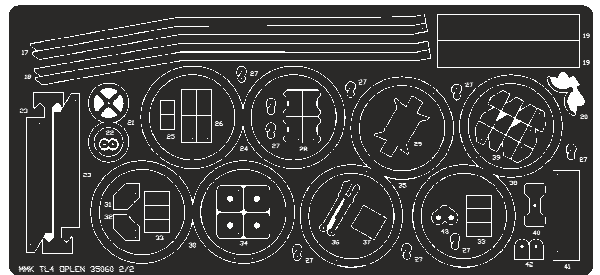
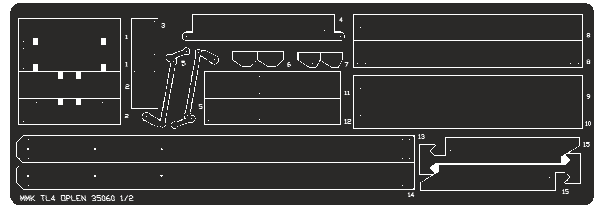
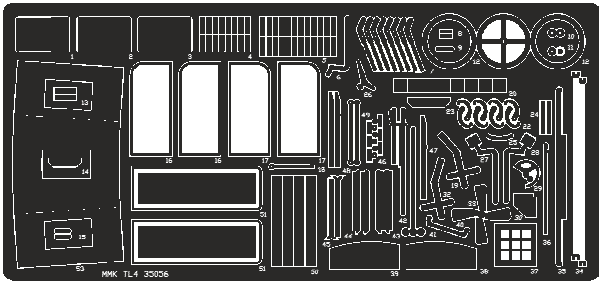
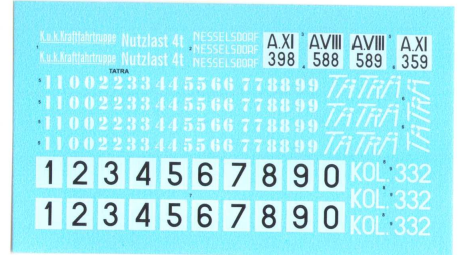

XX - RESIN PARTS

X - PHOTO-ETCHED PARTS 35056

X - PHOTO-ETCHED PARTS 35060

TL-4 OPLEN $\frac{1}{35}$ MMK

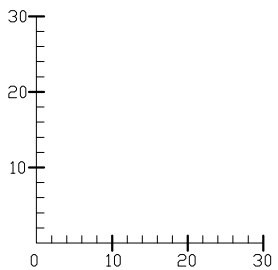
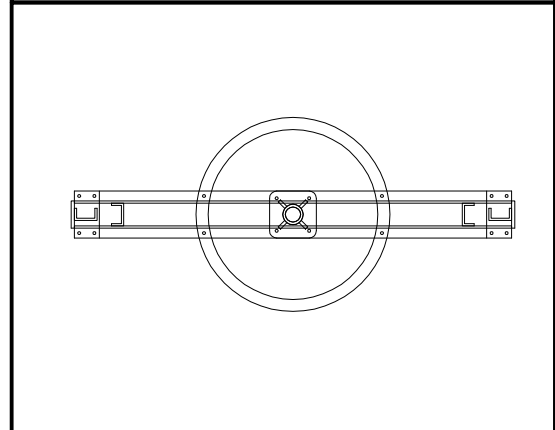
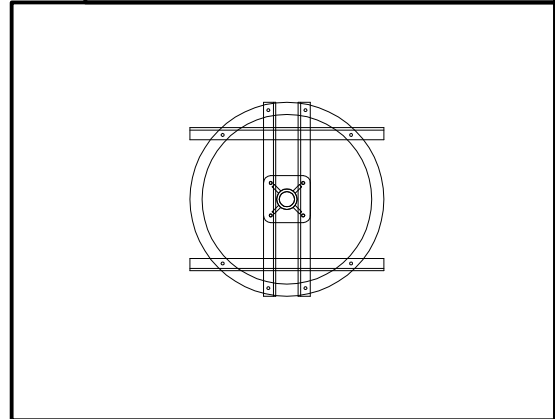
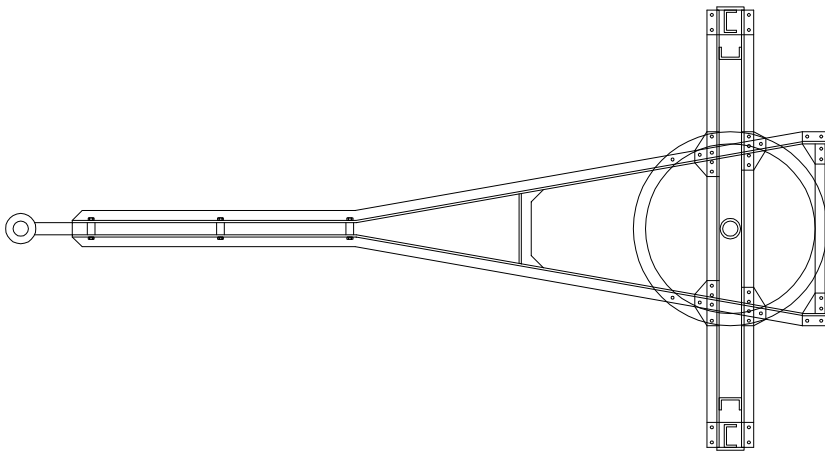
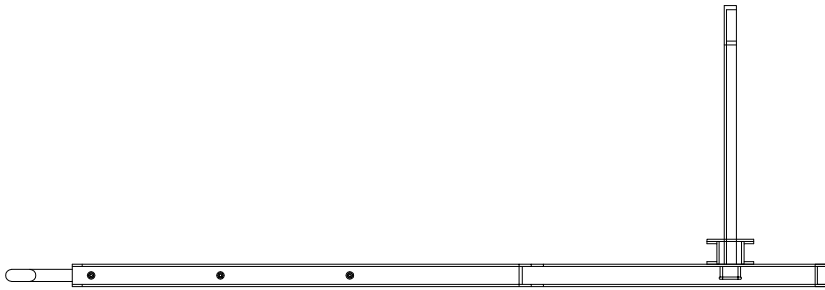
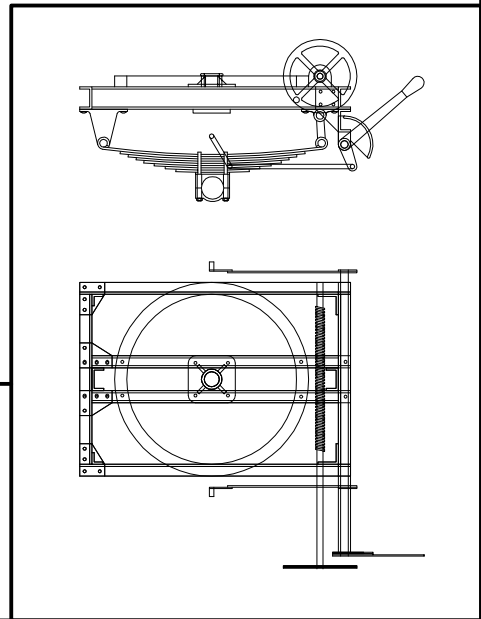
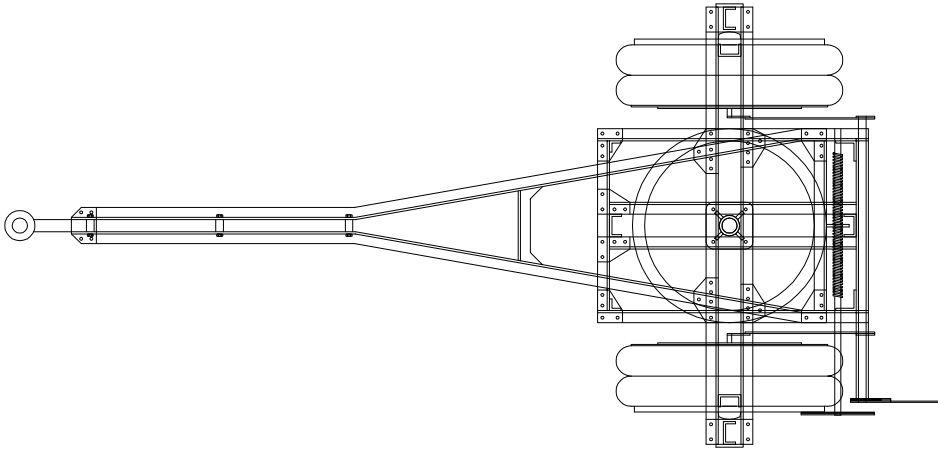
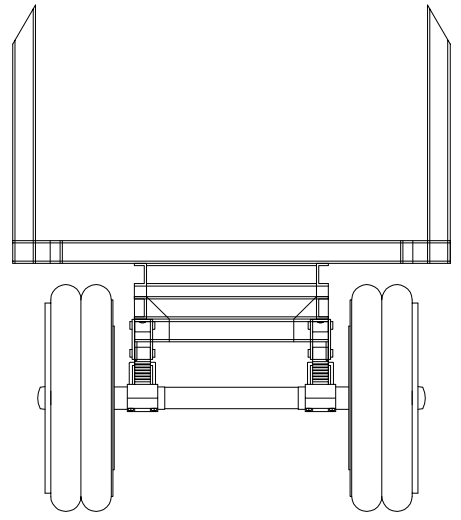
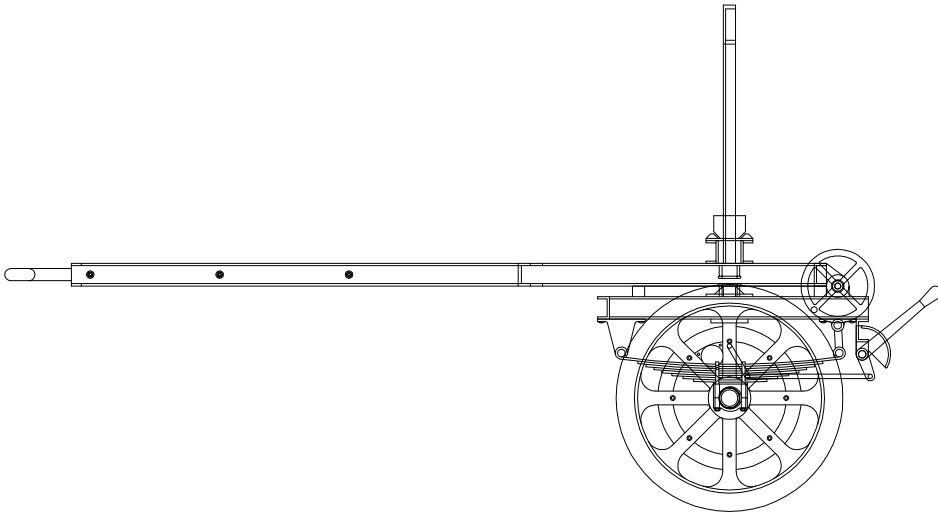

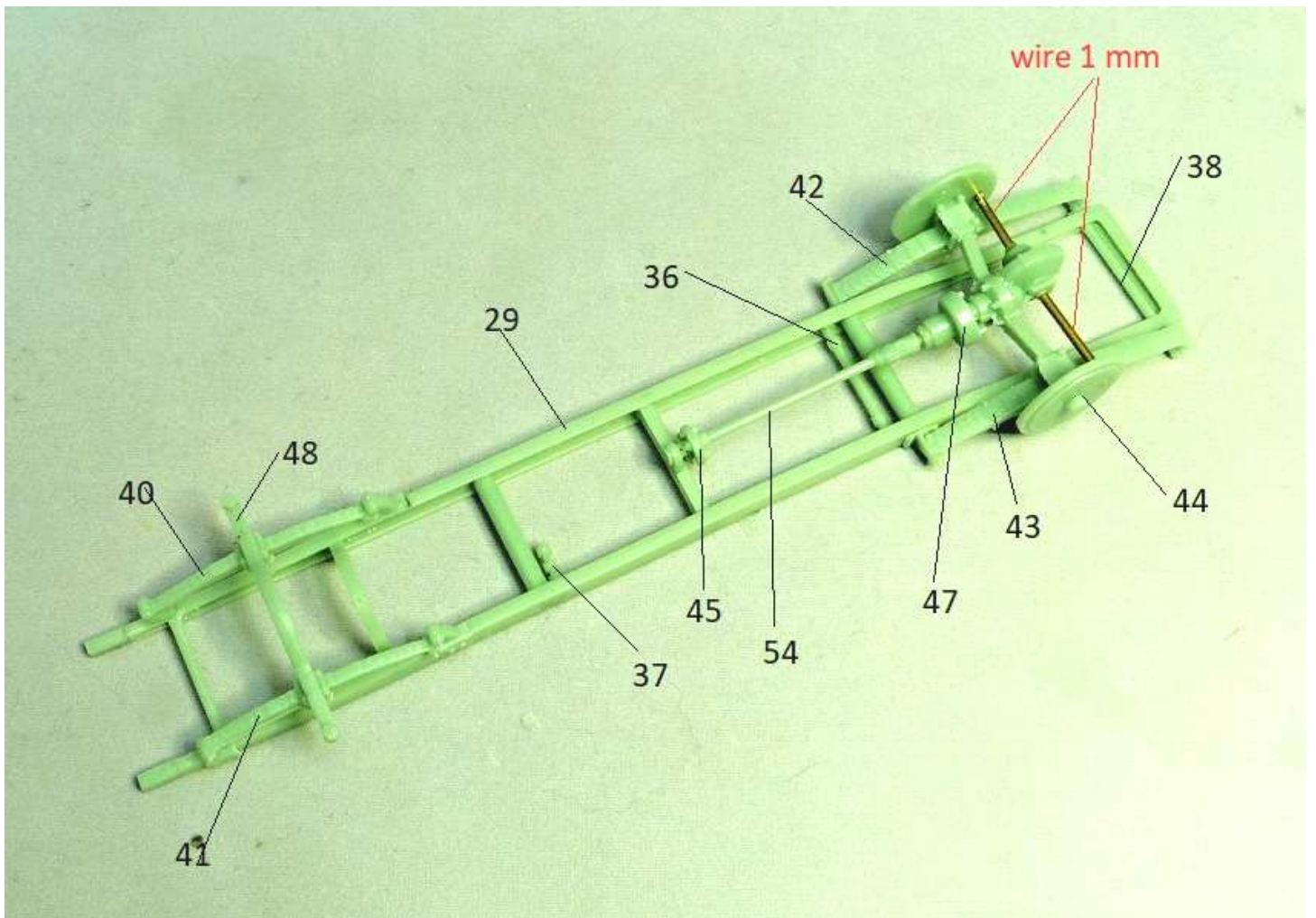
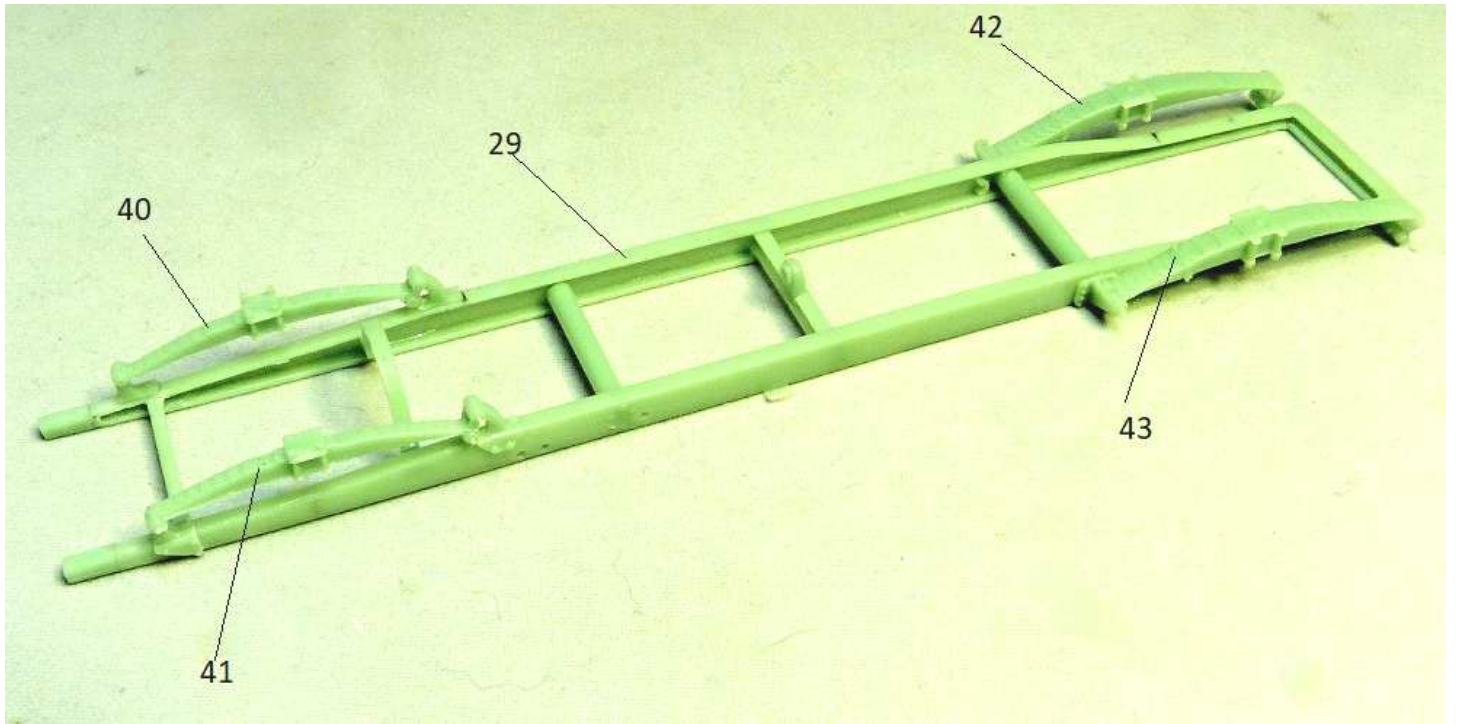
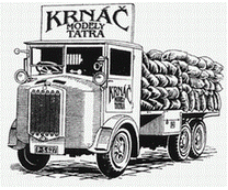

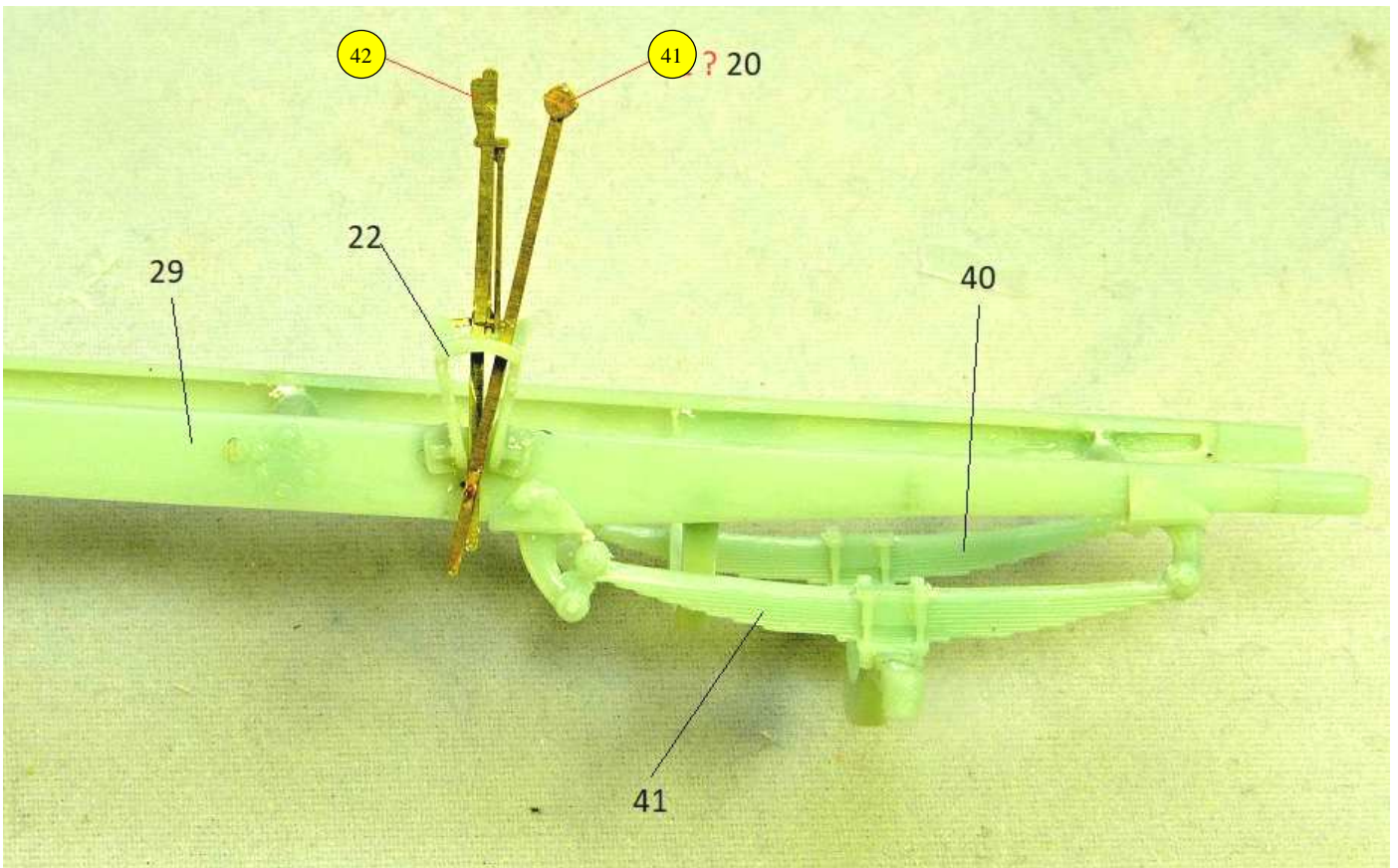
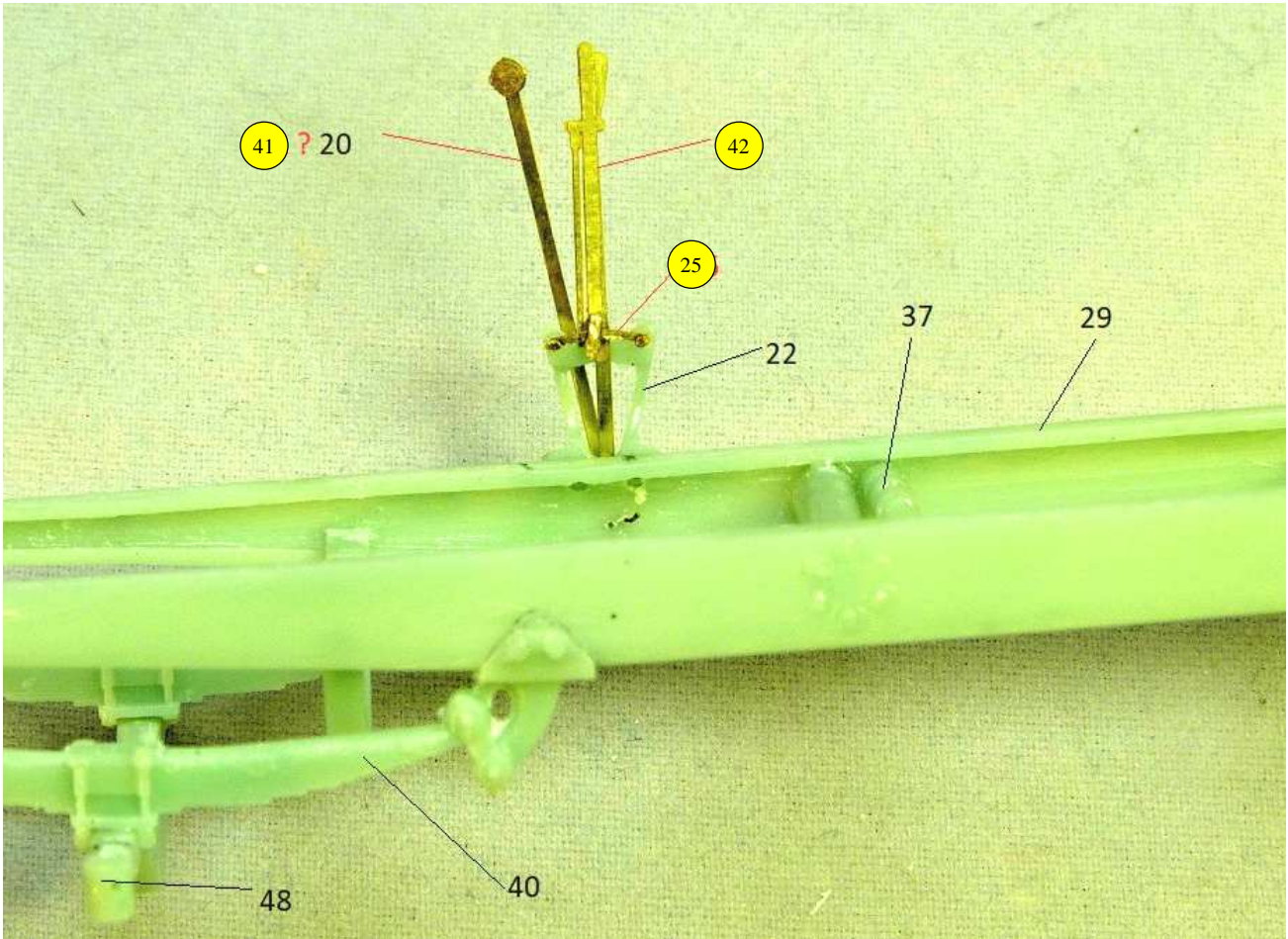
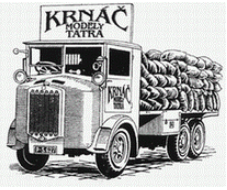

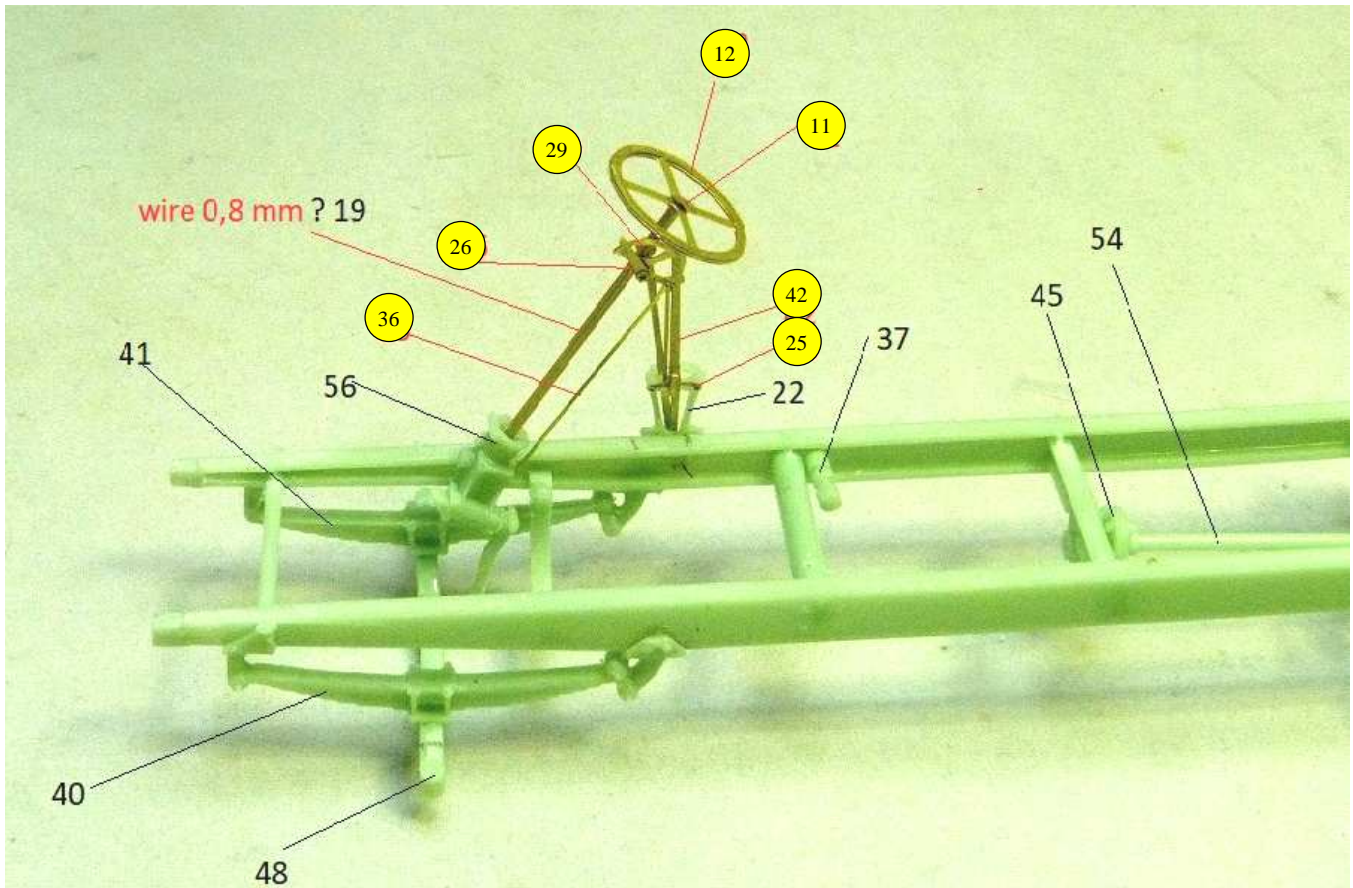
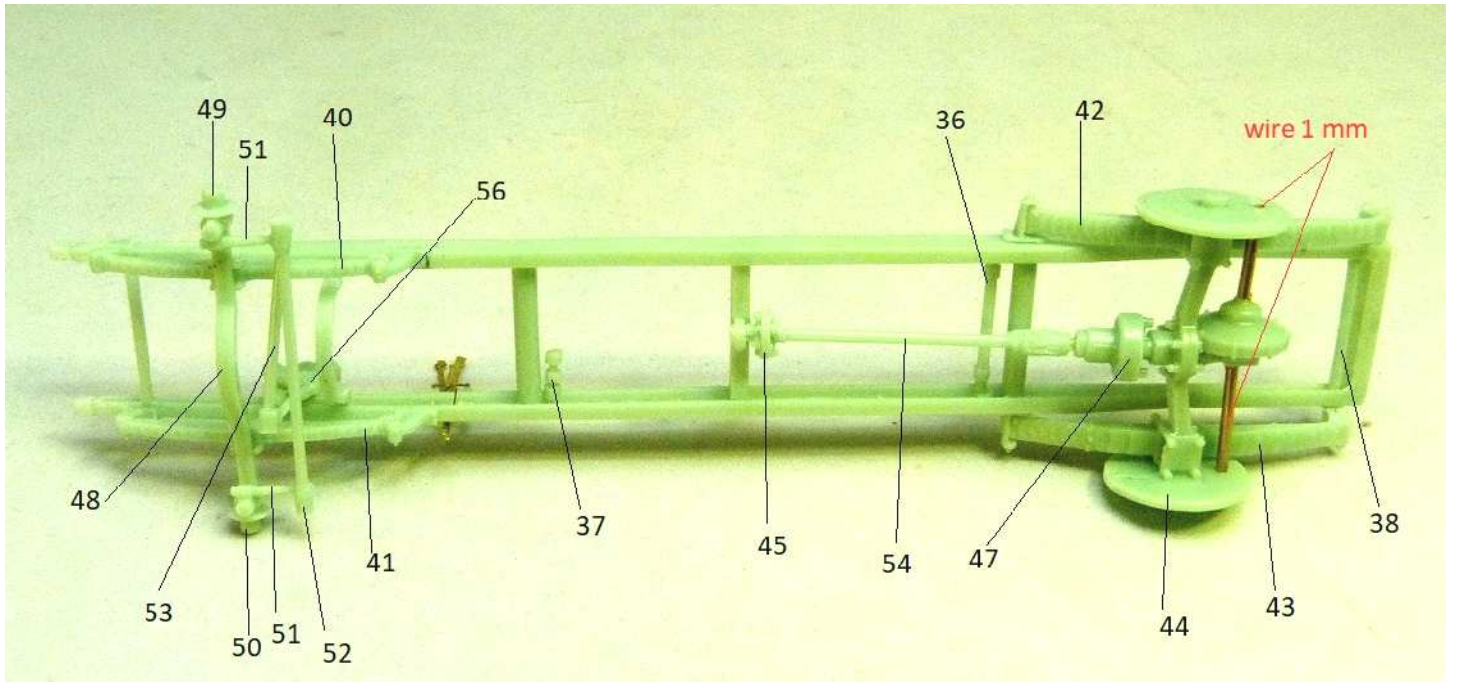
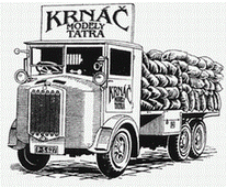

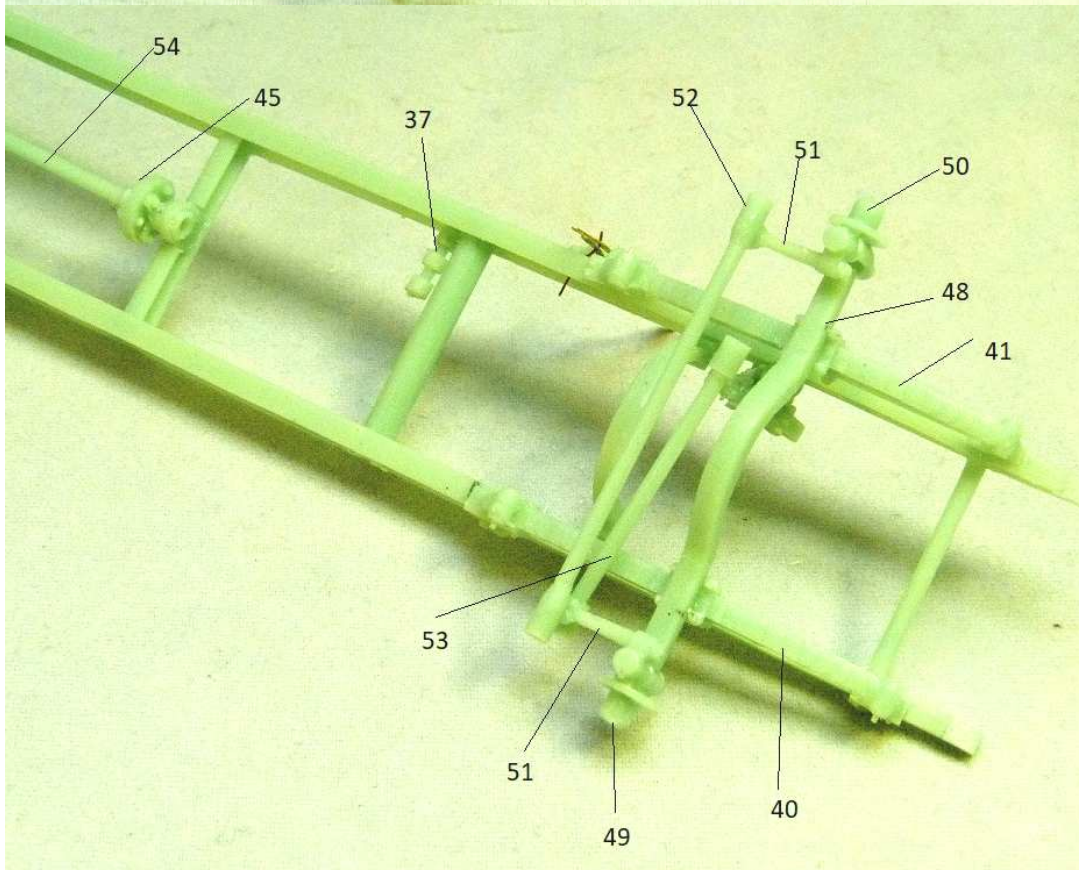
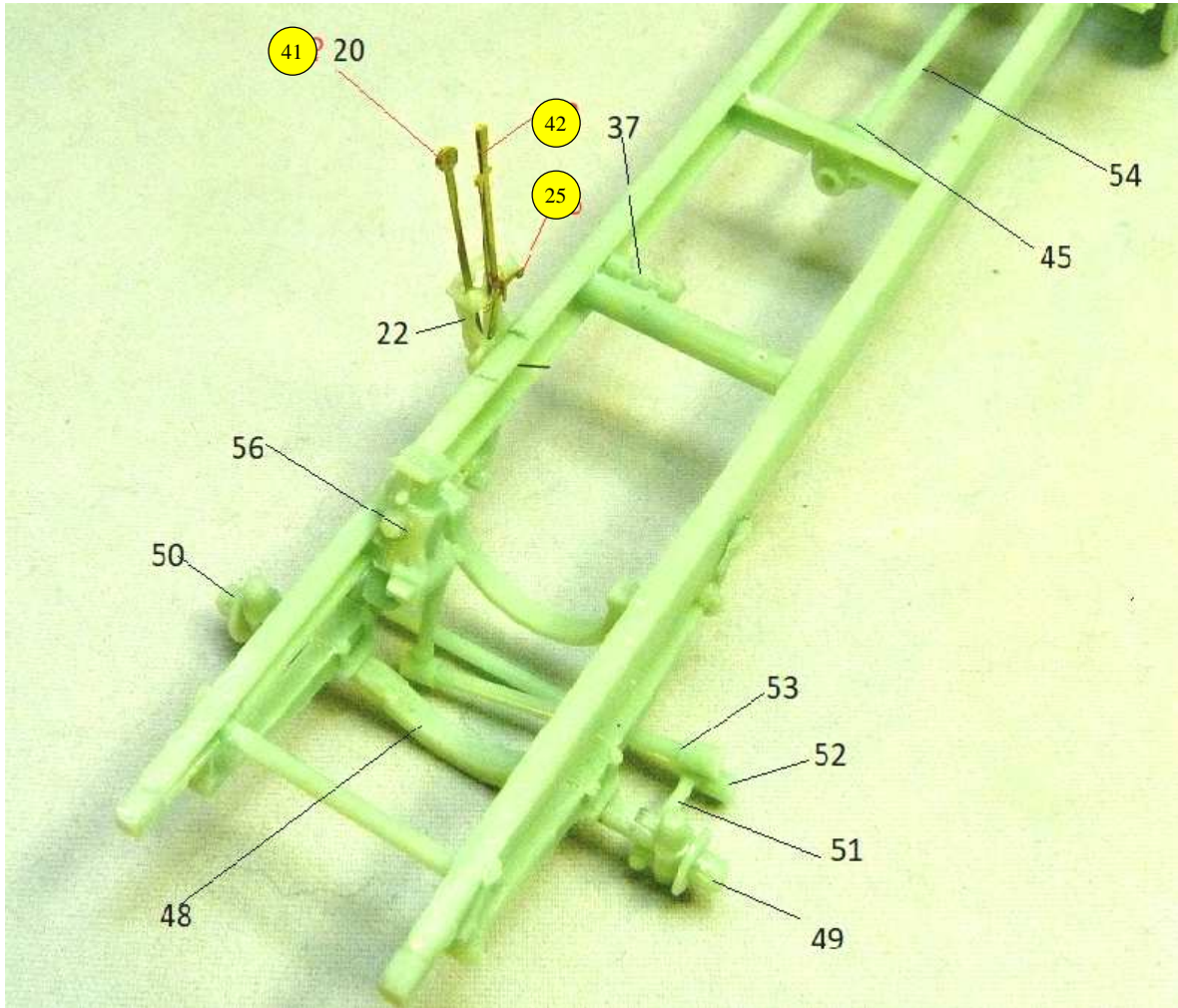
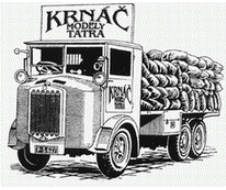

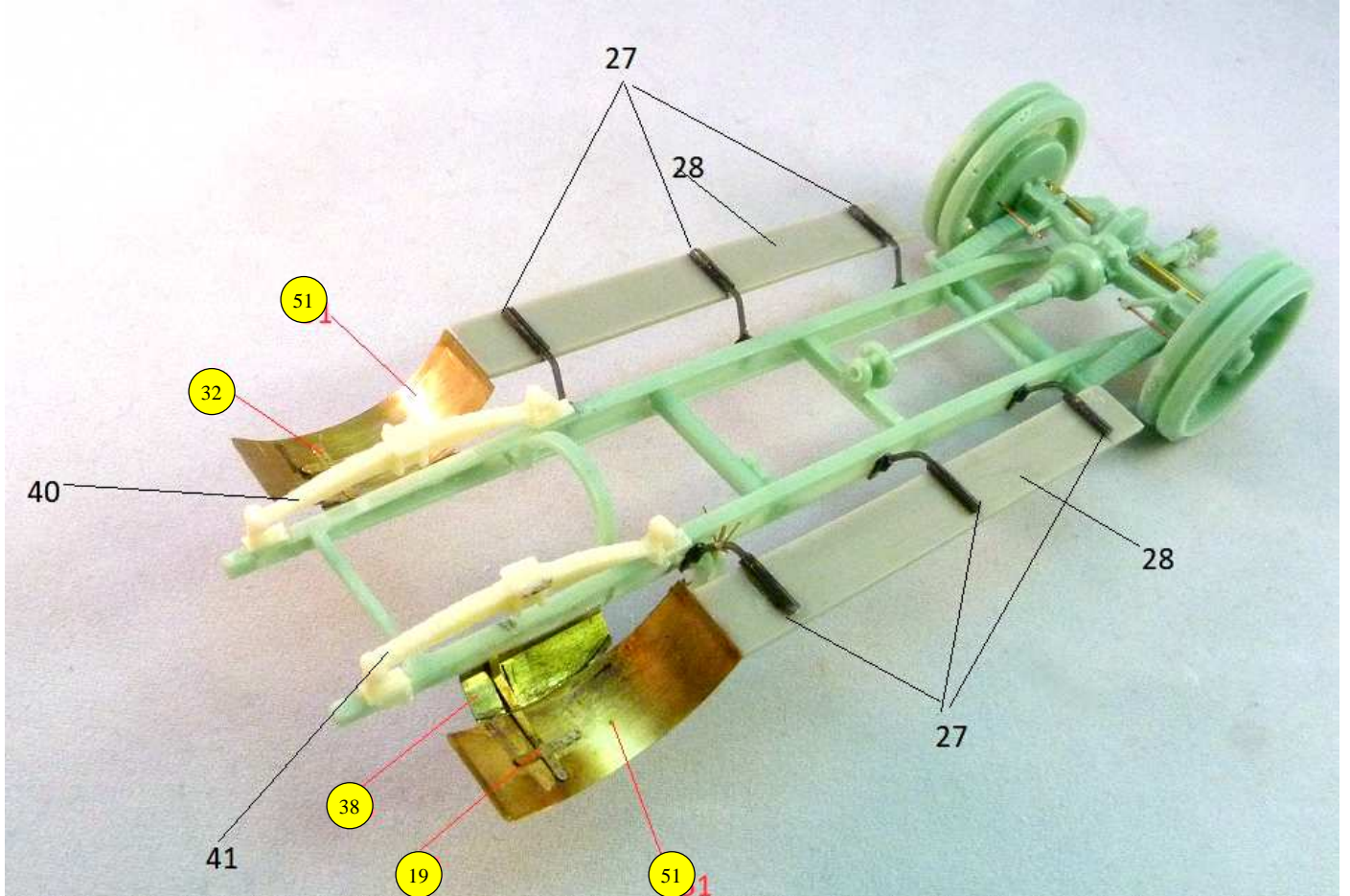
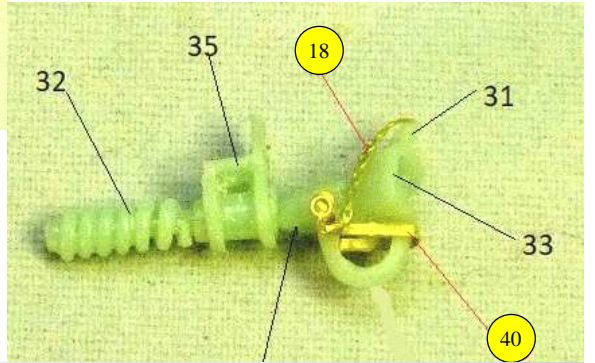
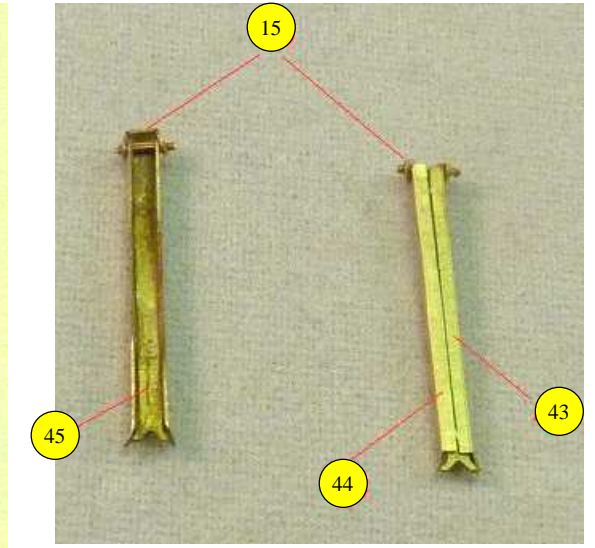
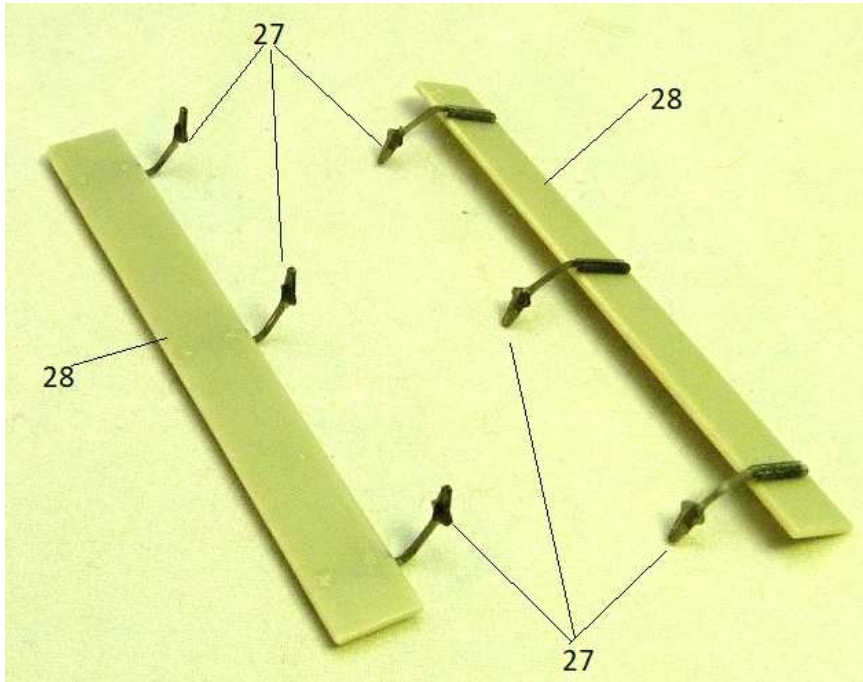
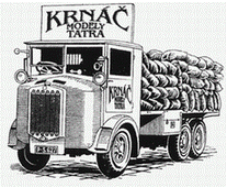

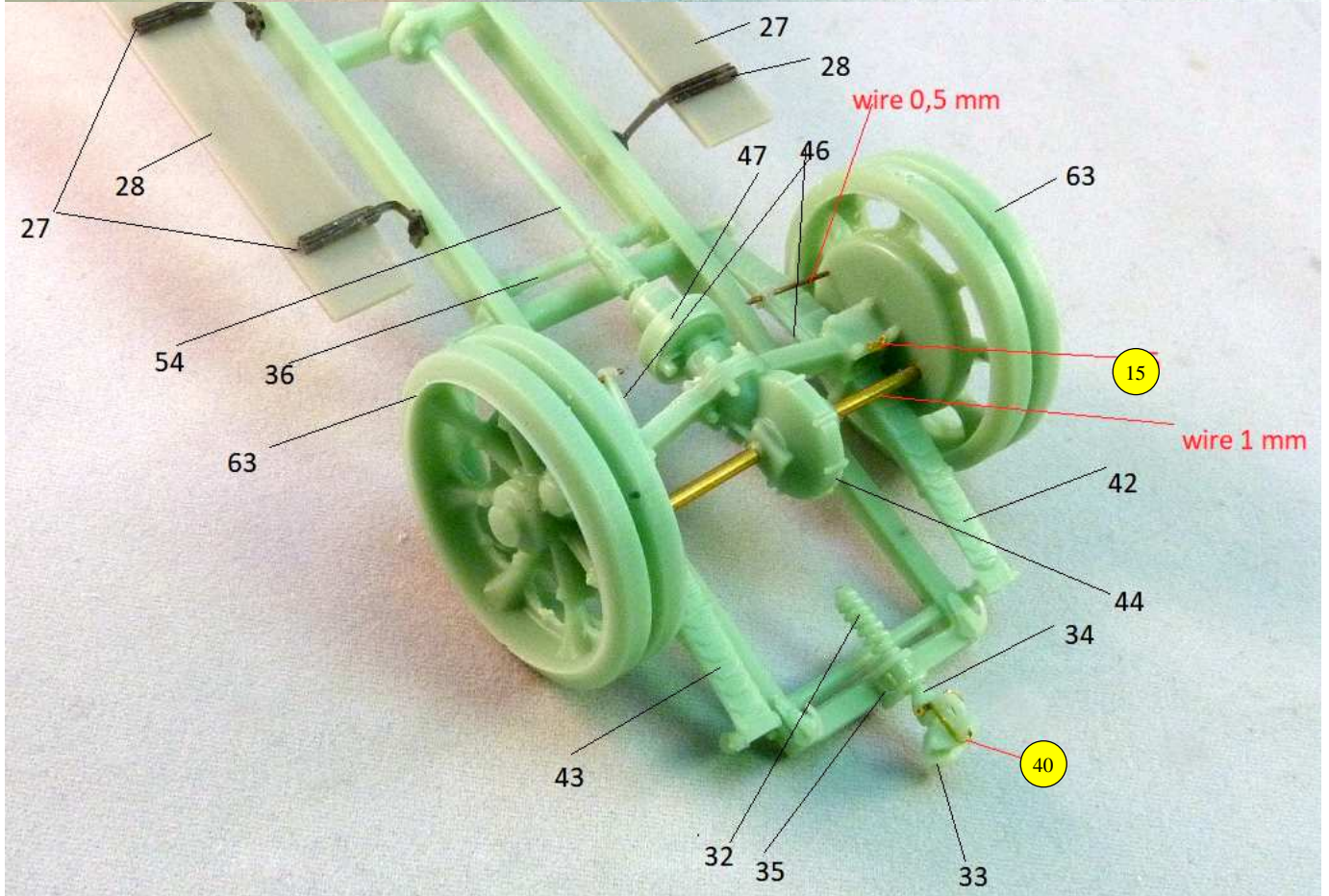
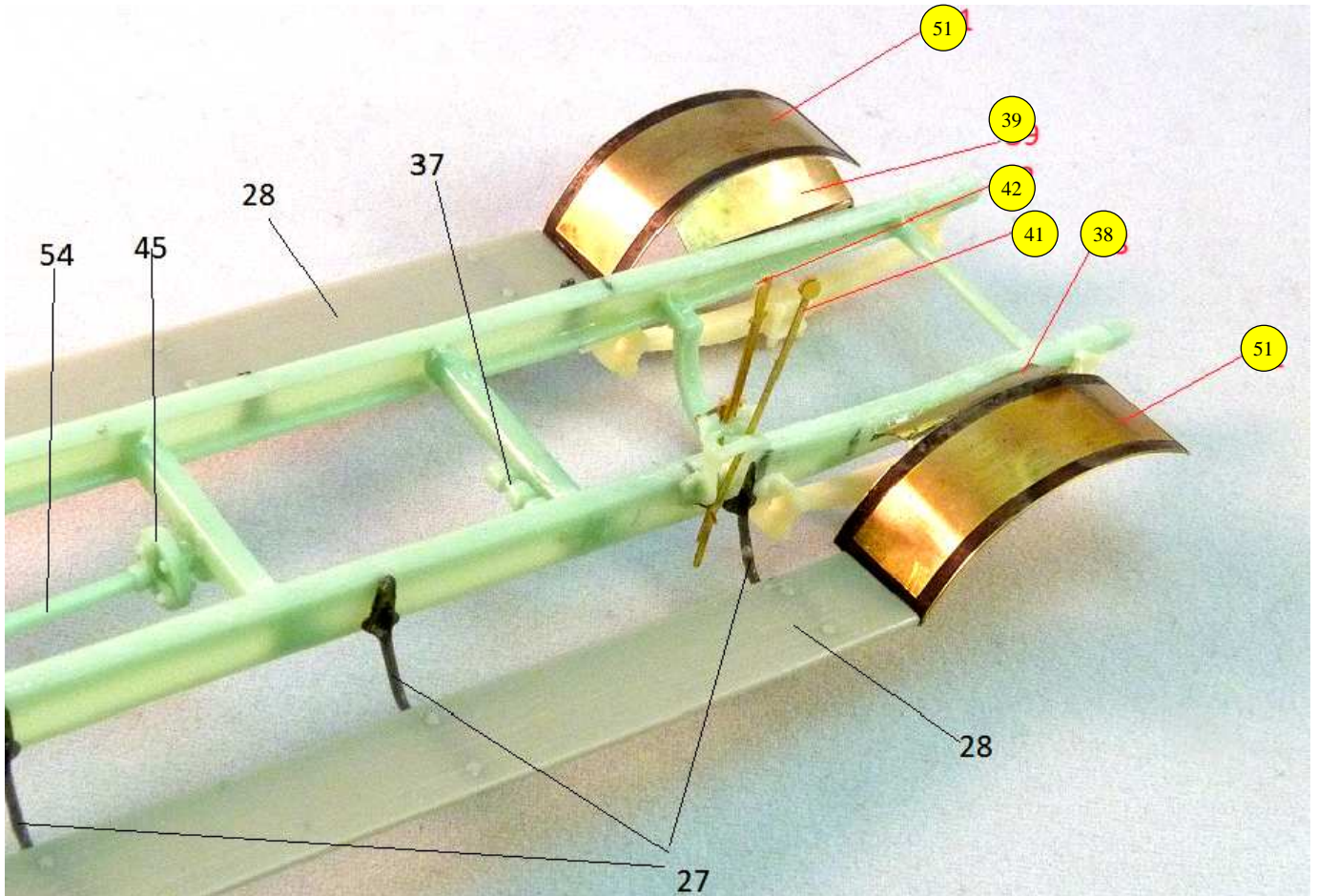
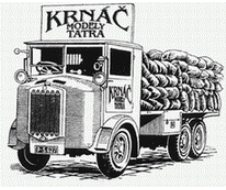

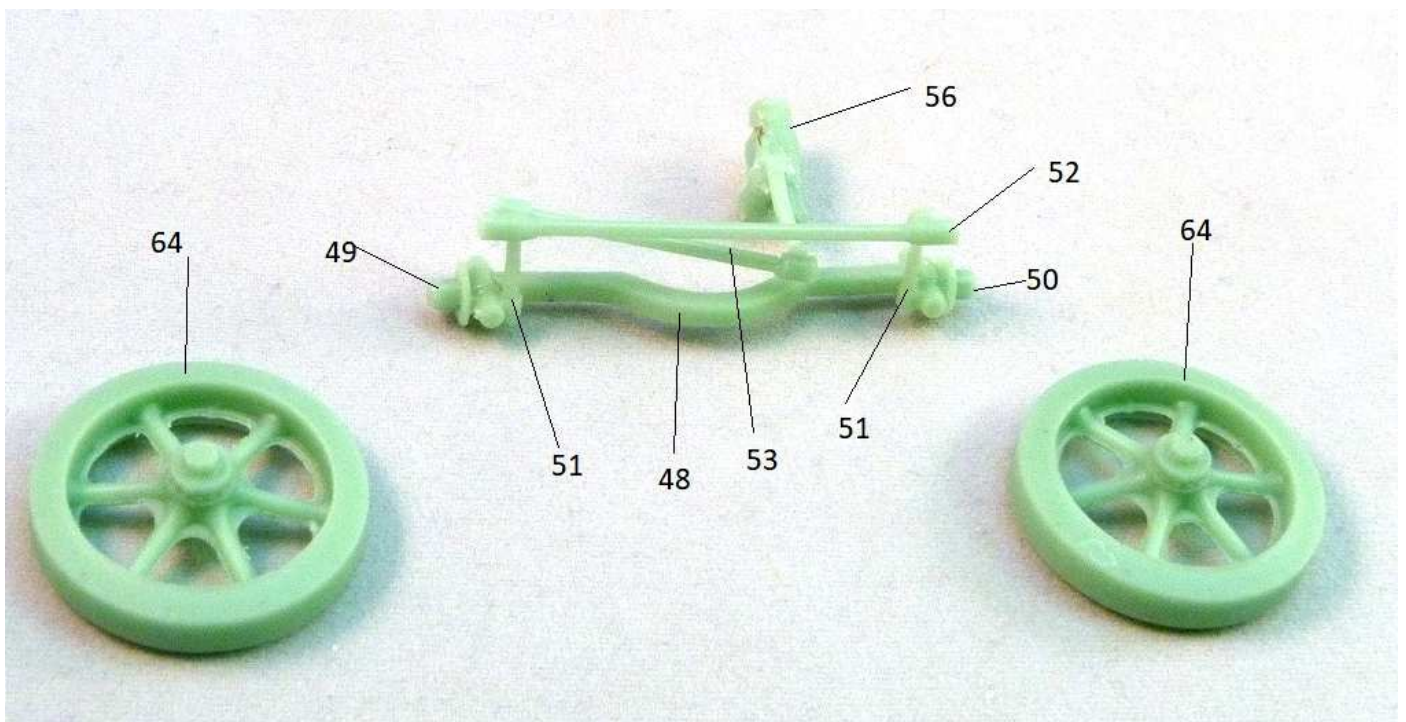
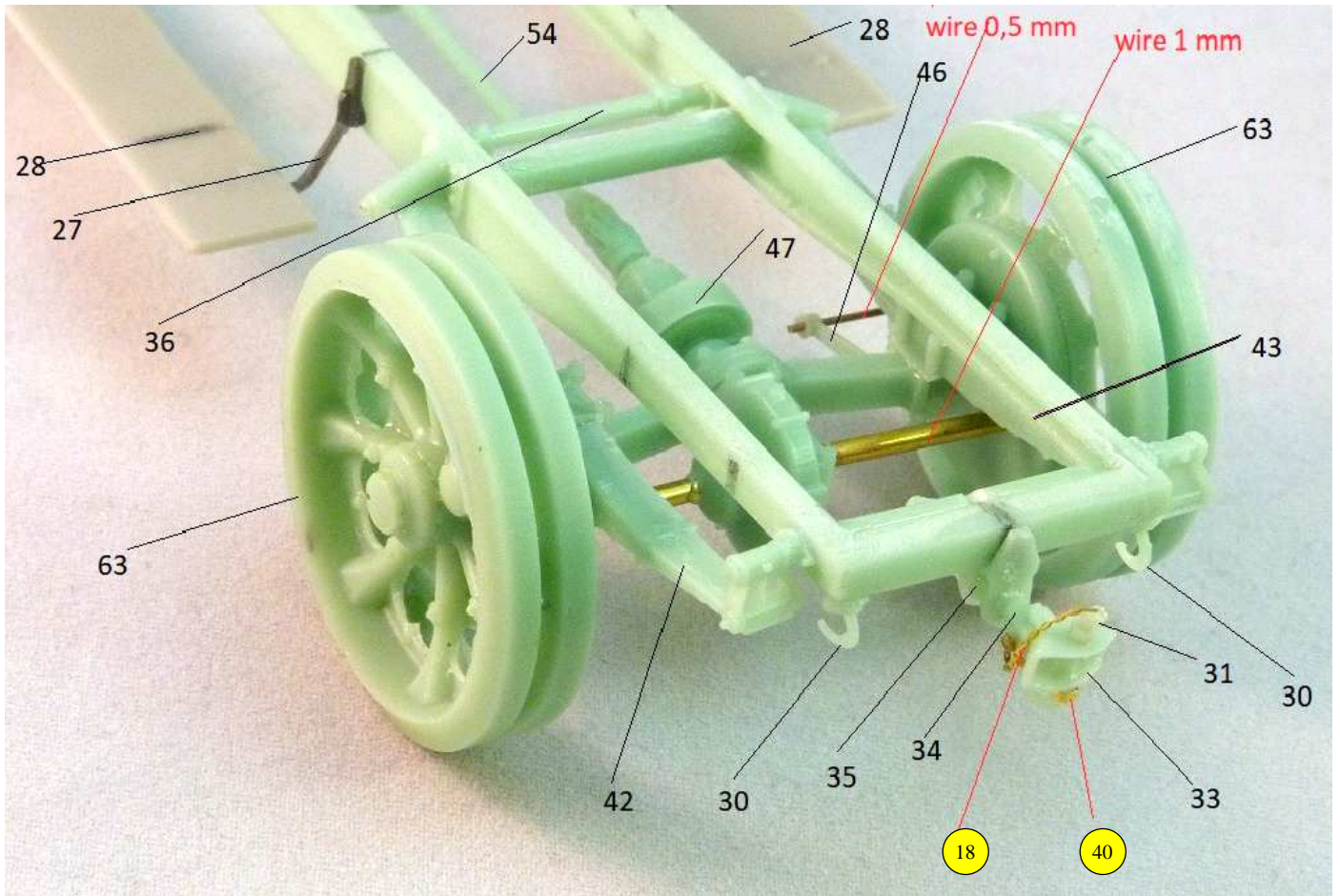
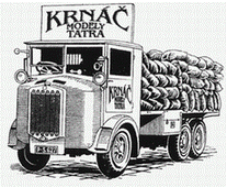

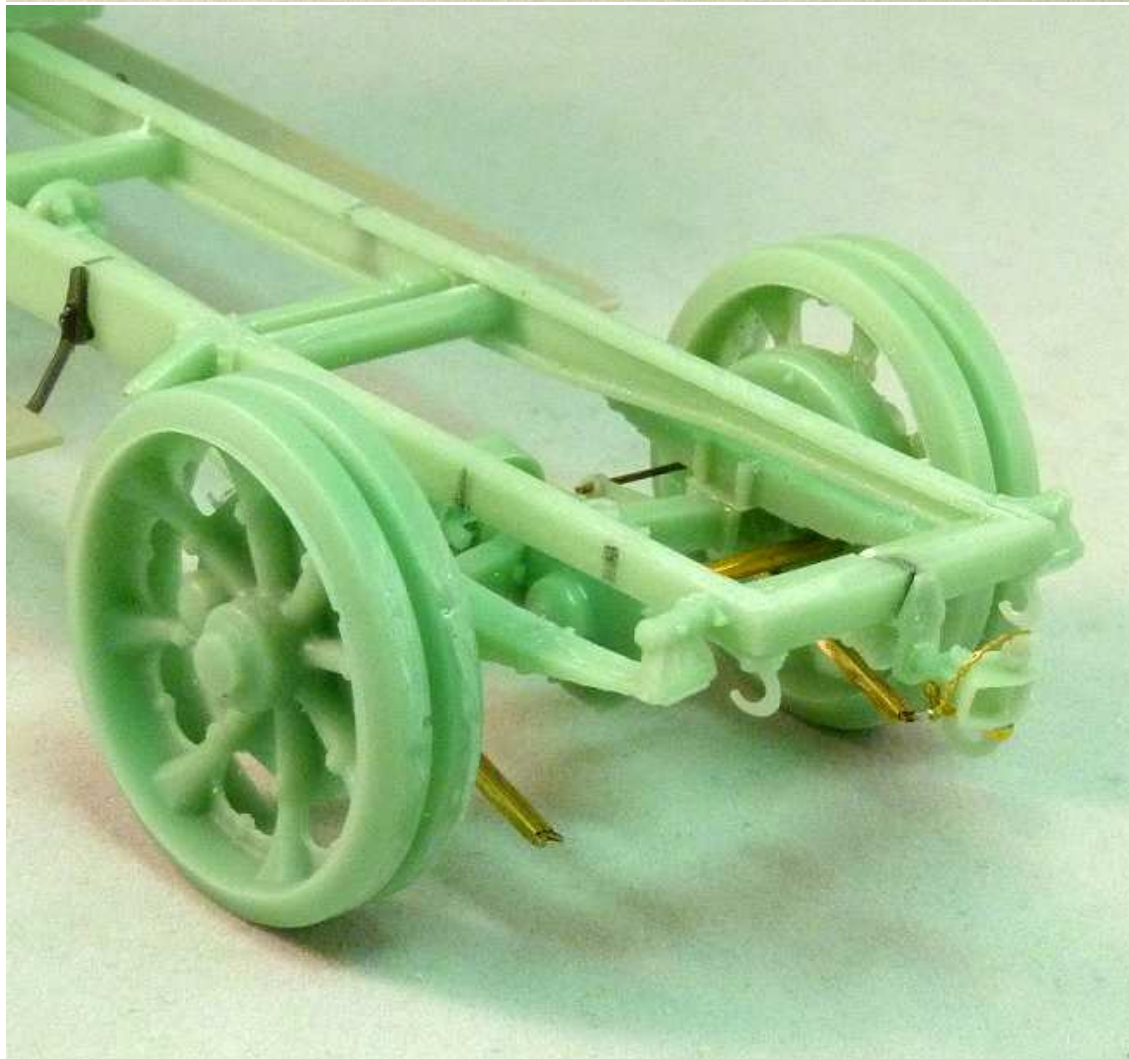
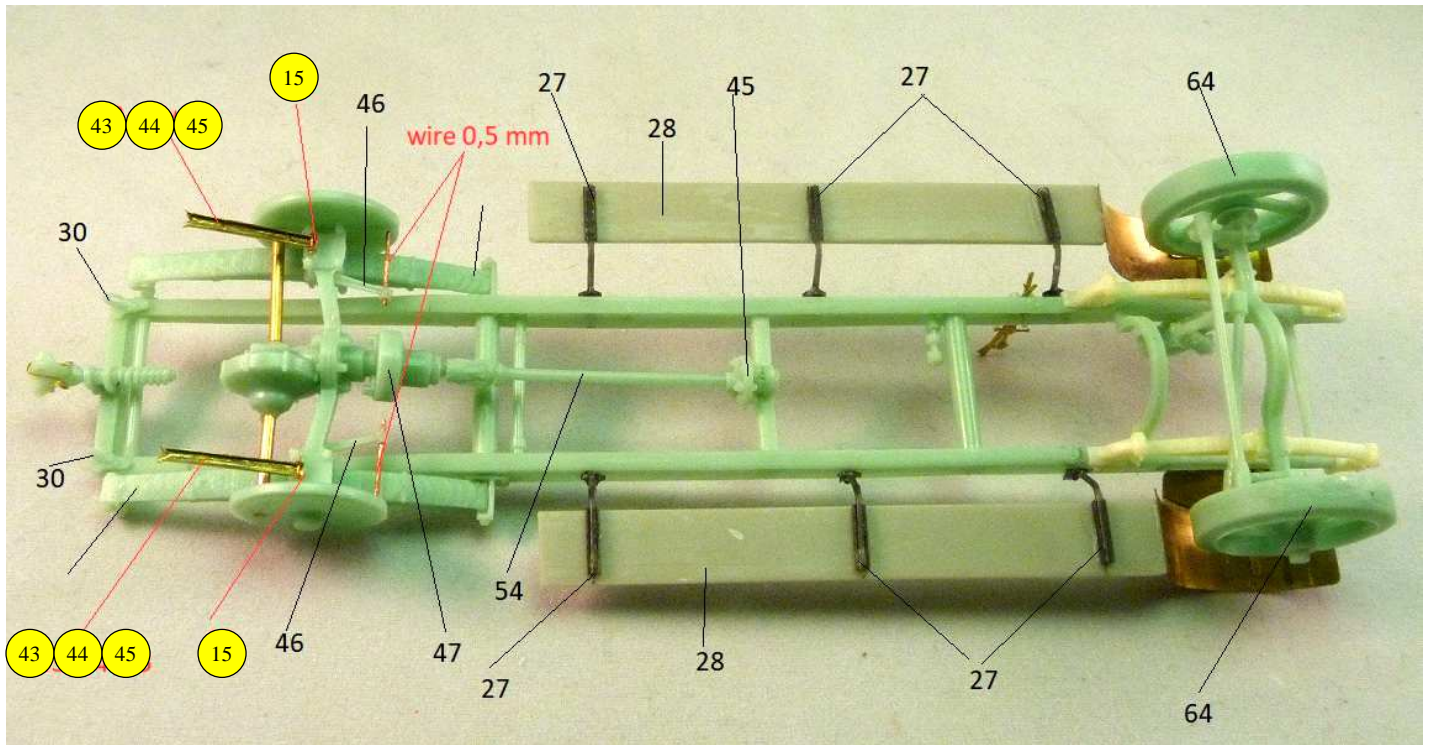
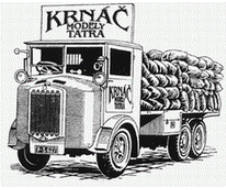

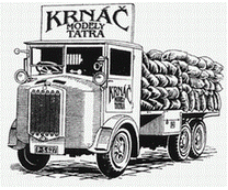

TL-4 OPLEN

1/35

35060

12/32

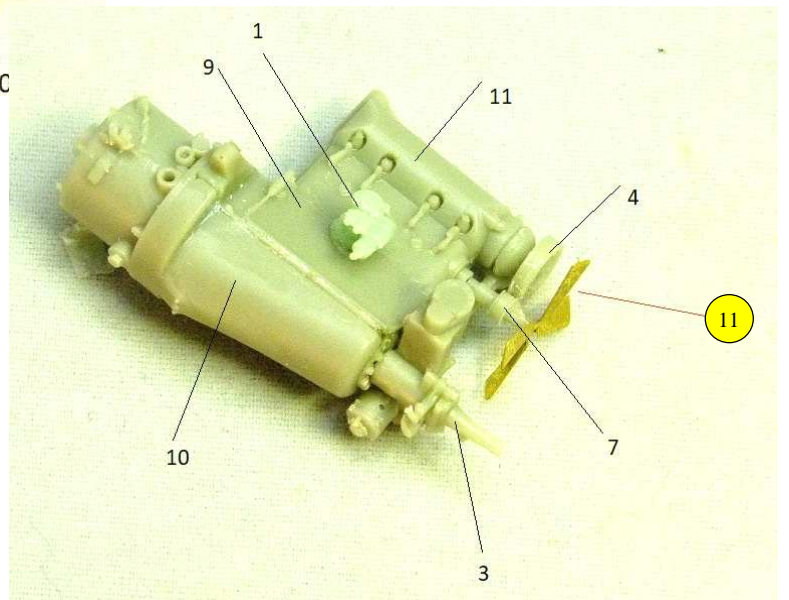
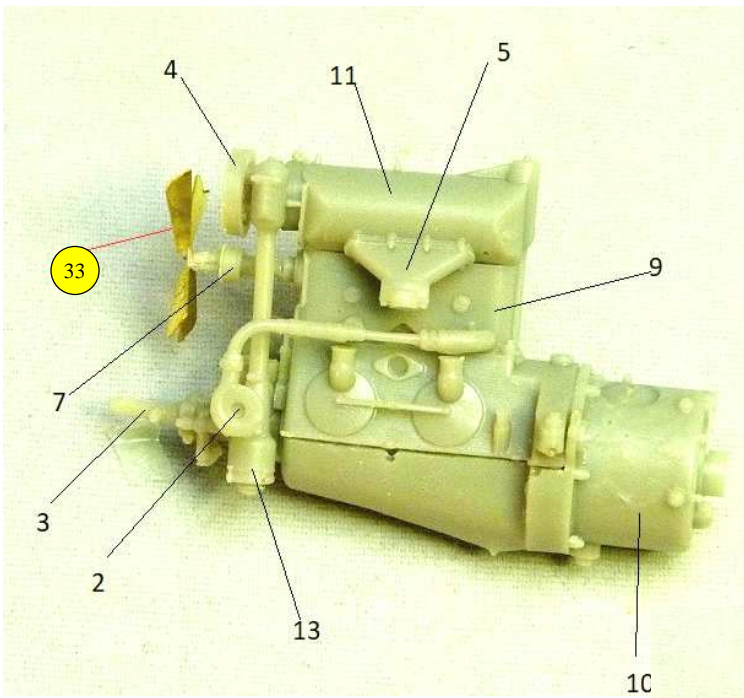
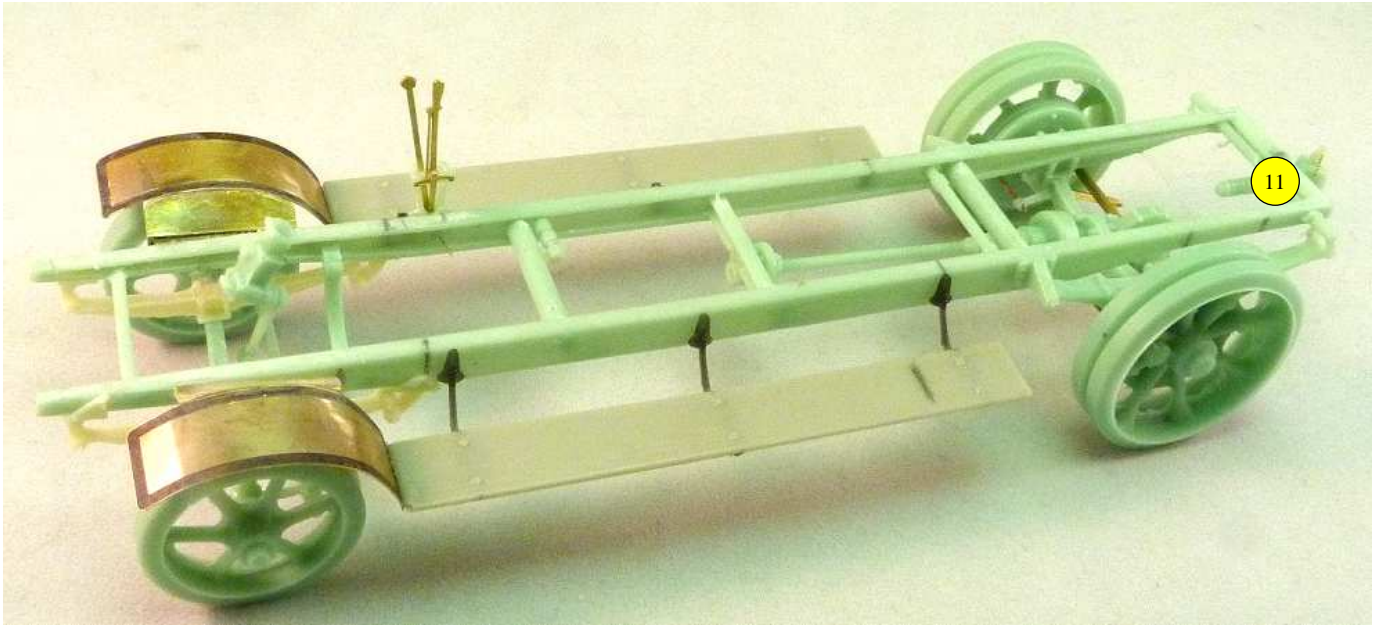

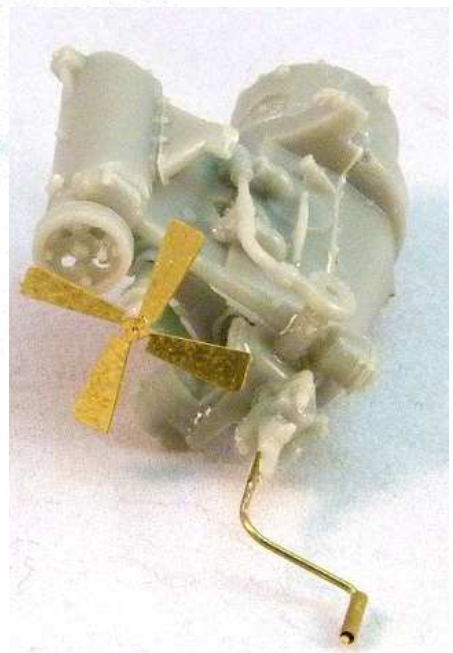
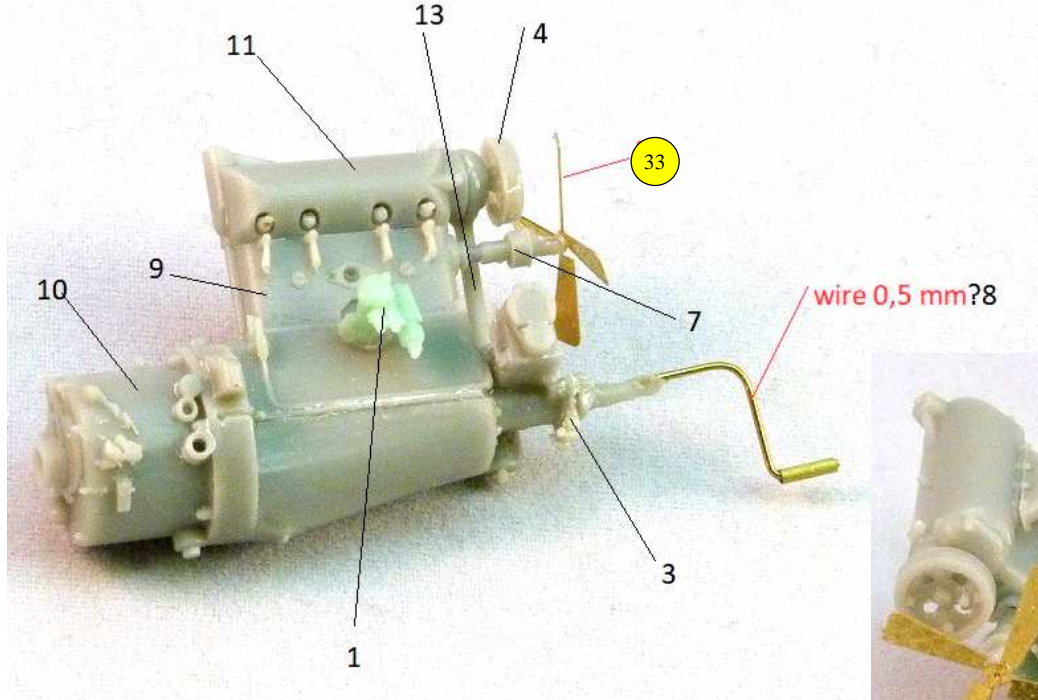
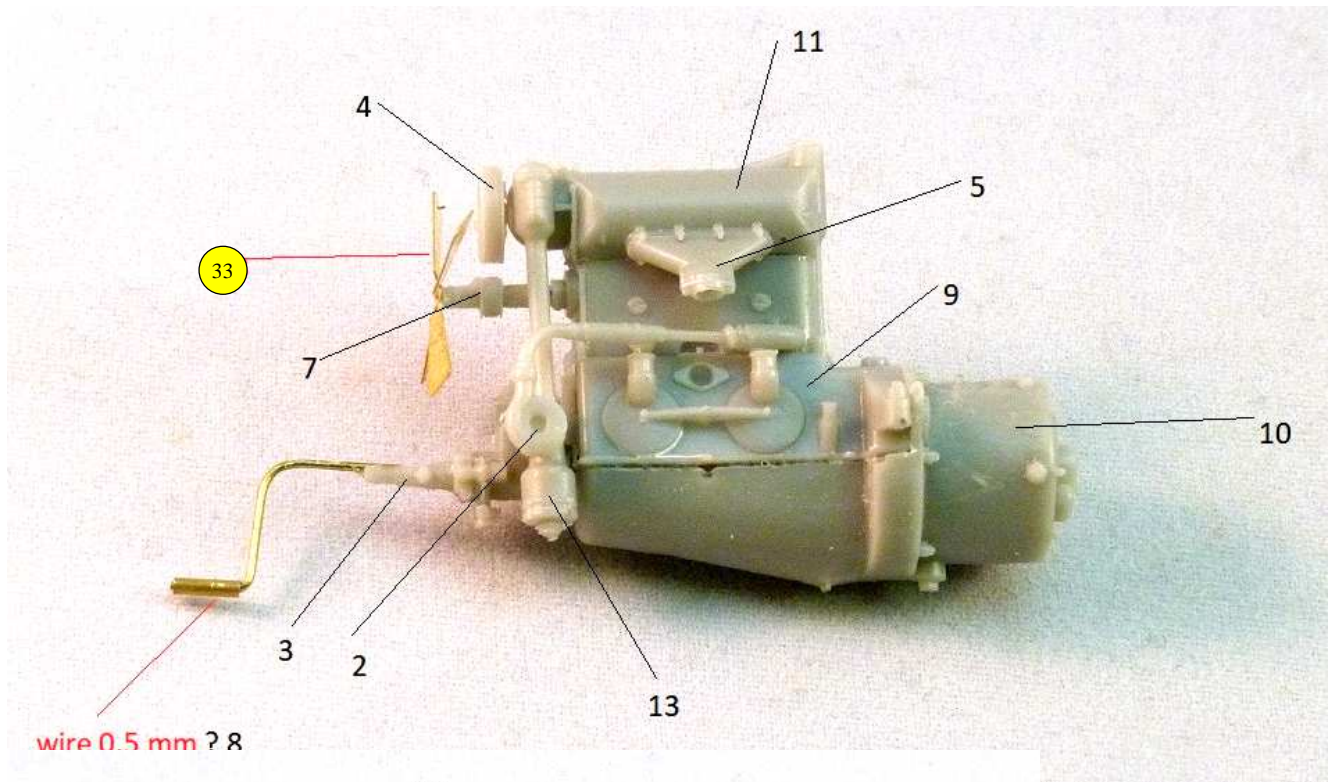

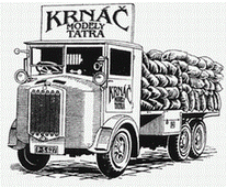

TL-4 OPLEN

1/35

35060

14/32

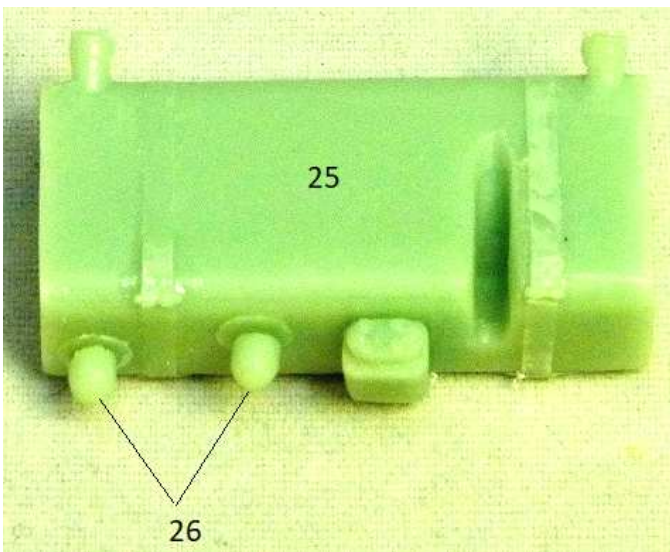
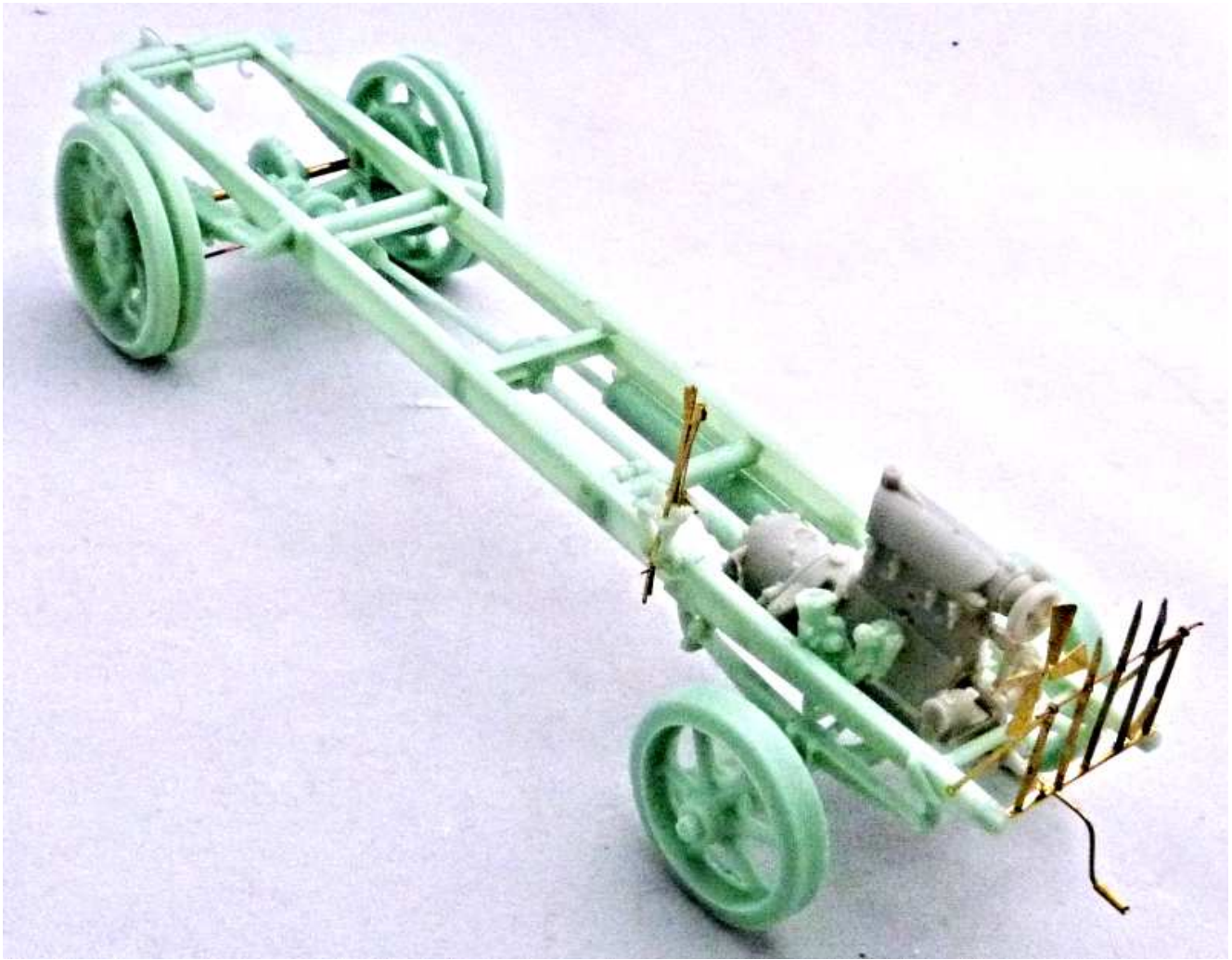

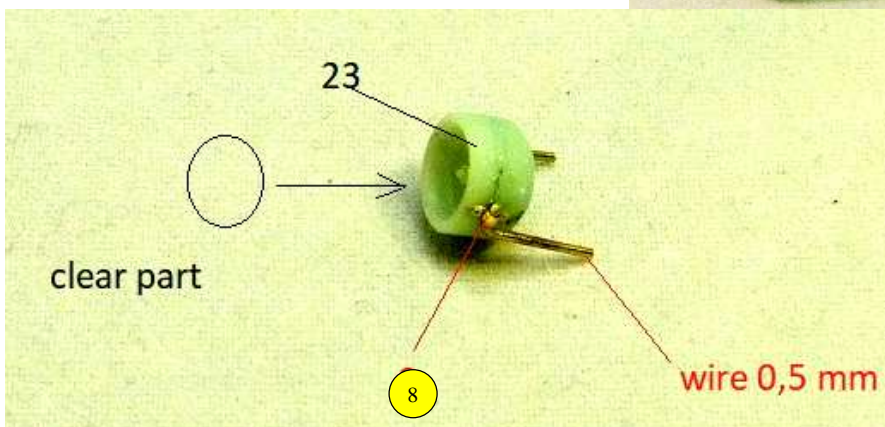
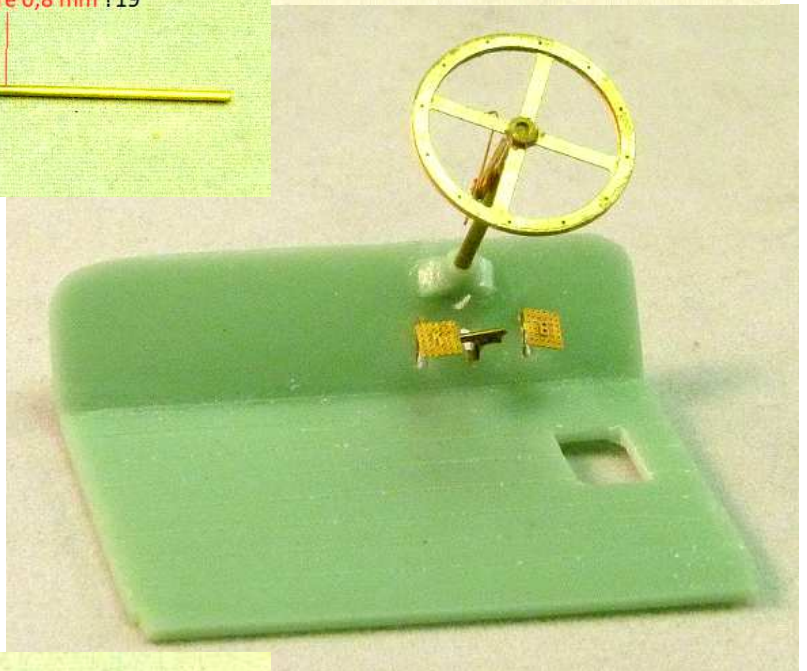
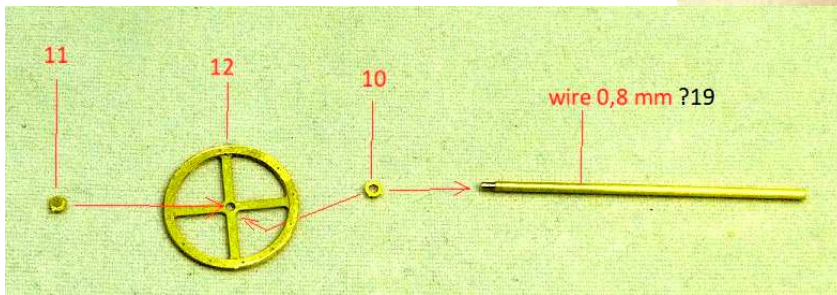
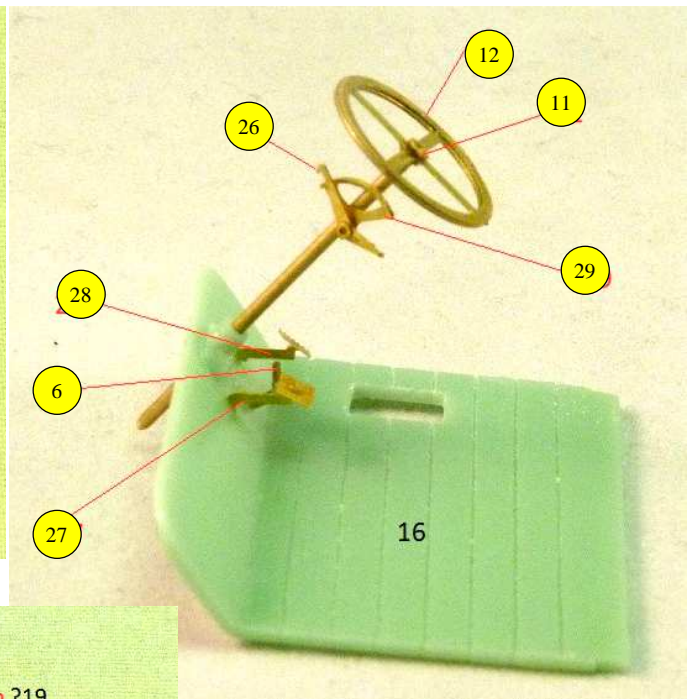
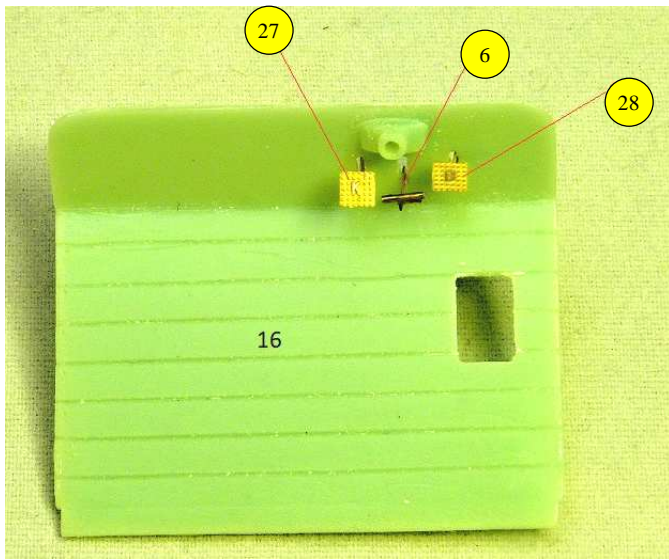
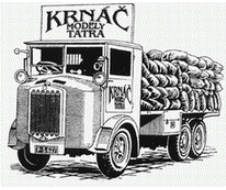

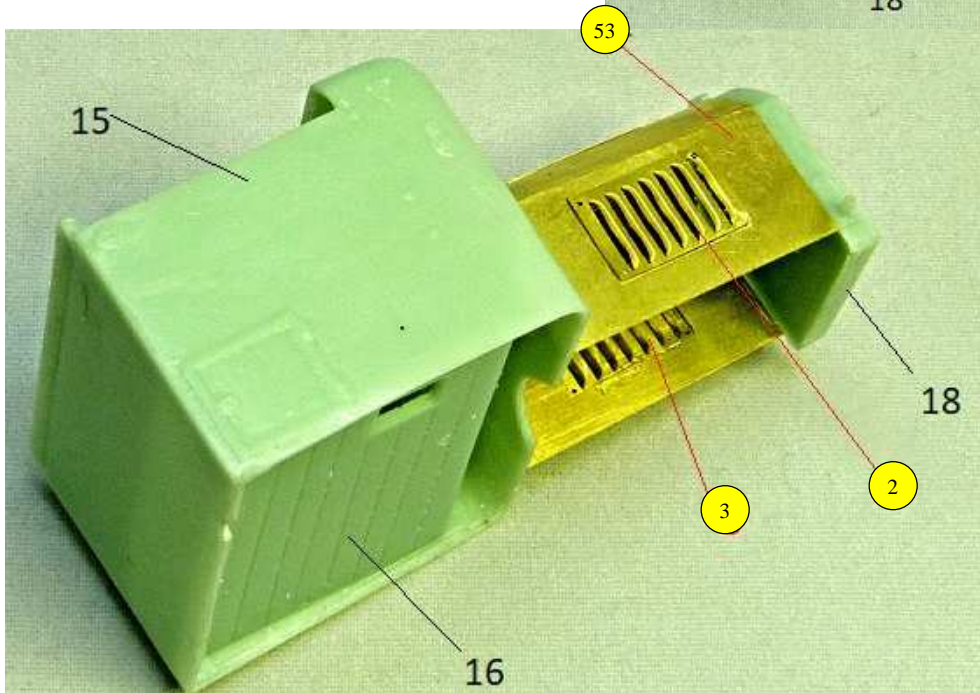
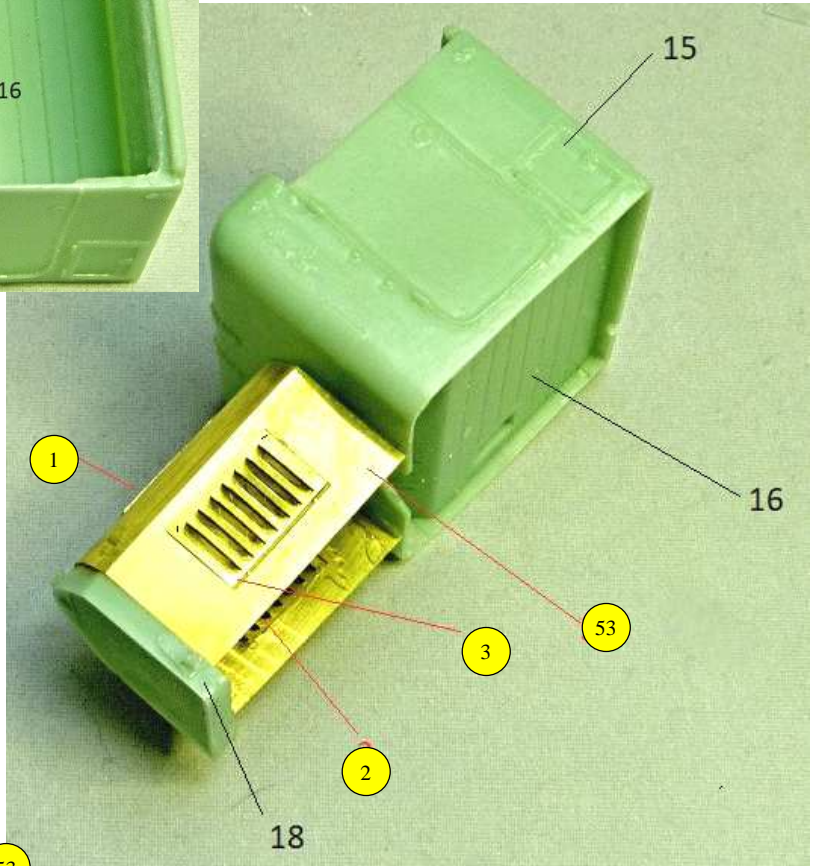
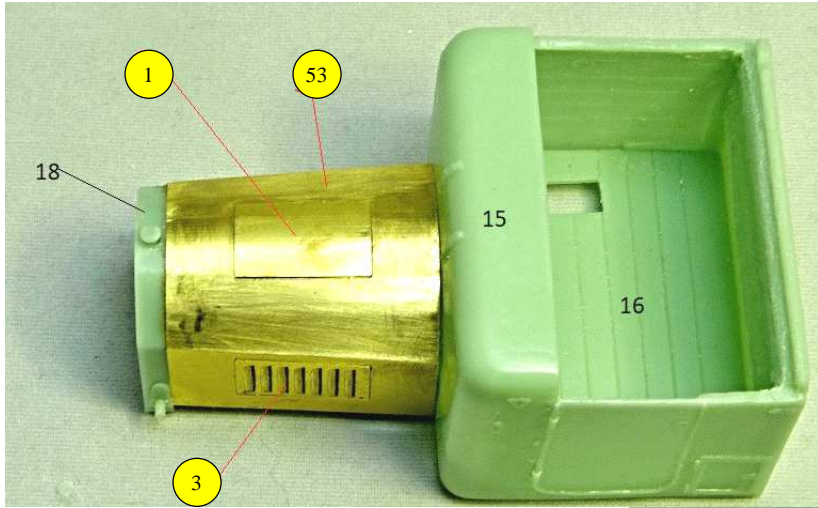
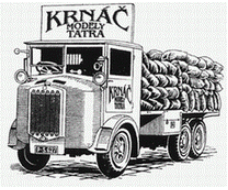

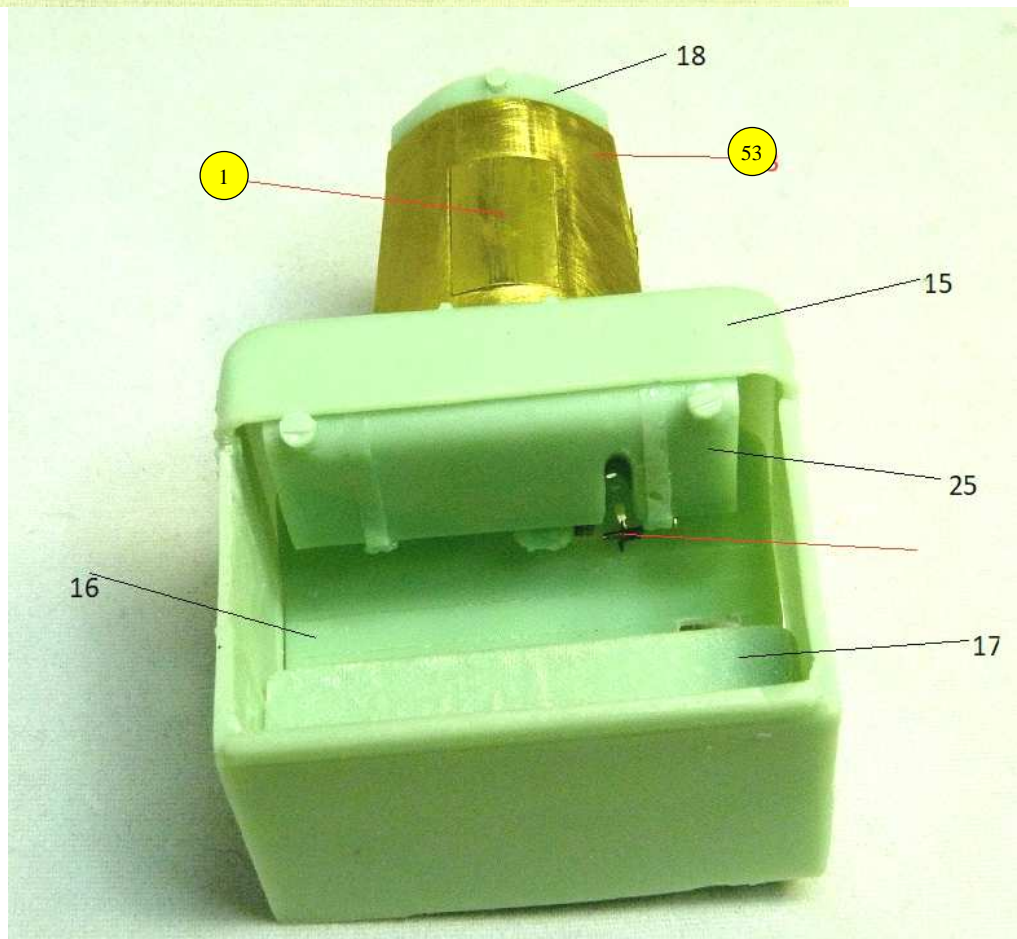
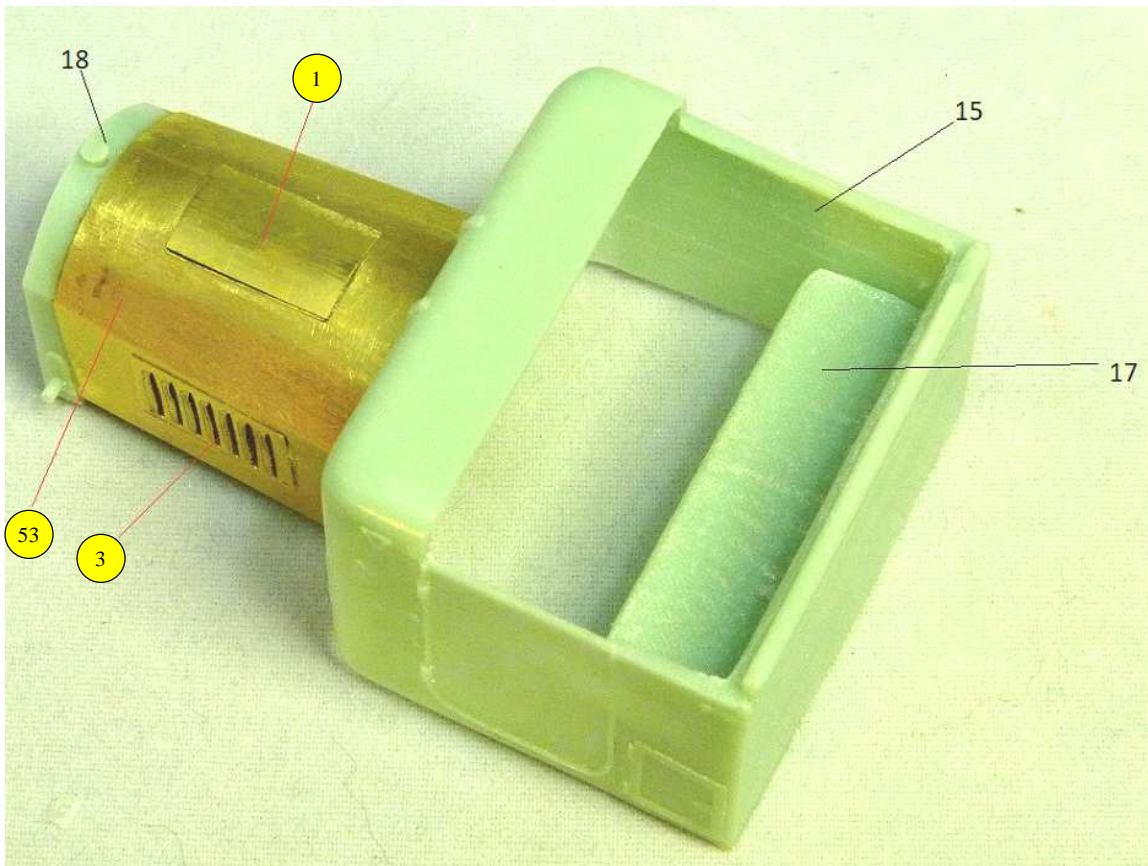
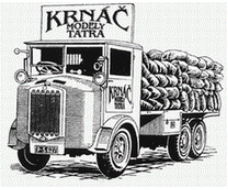

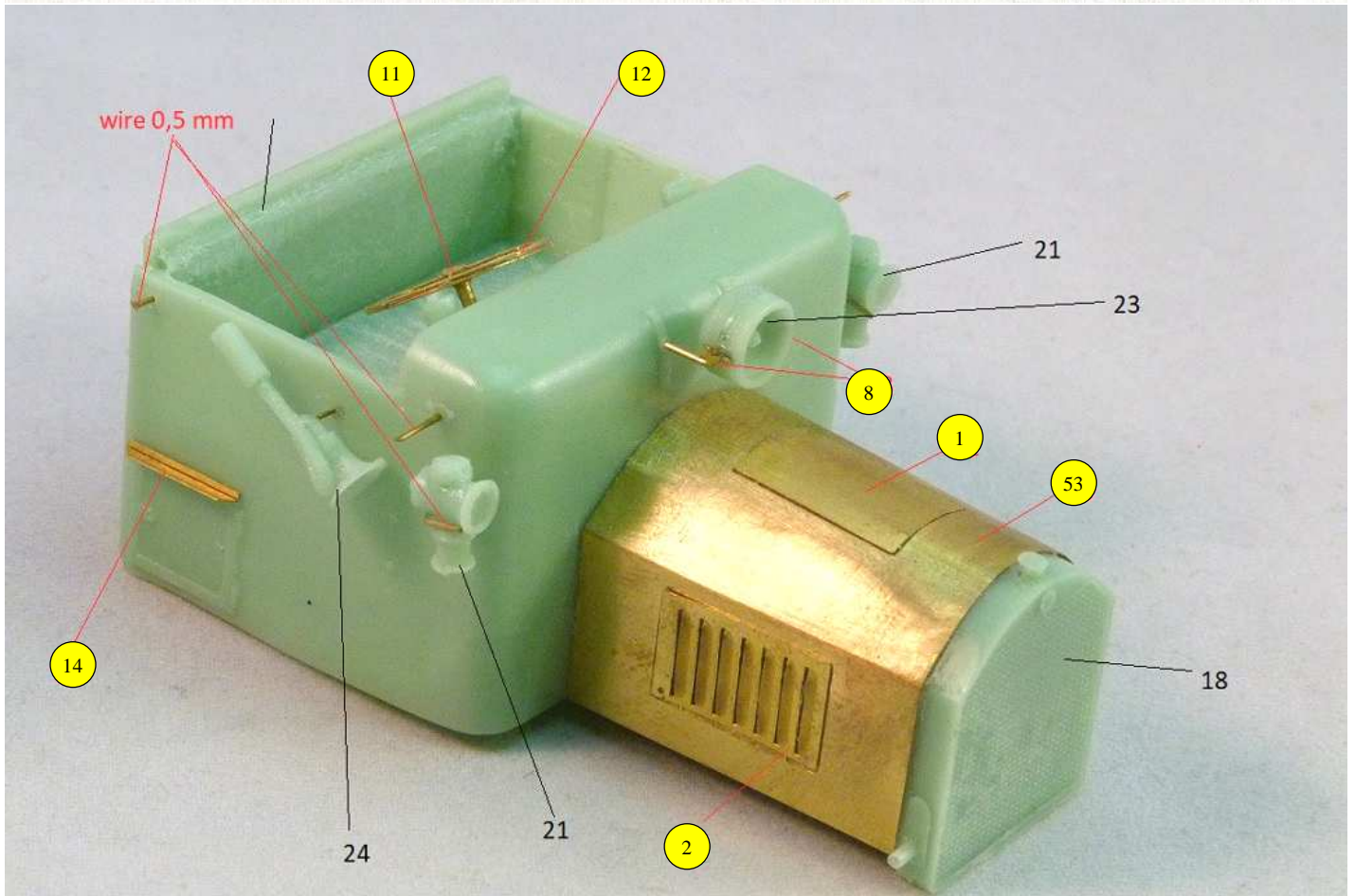
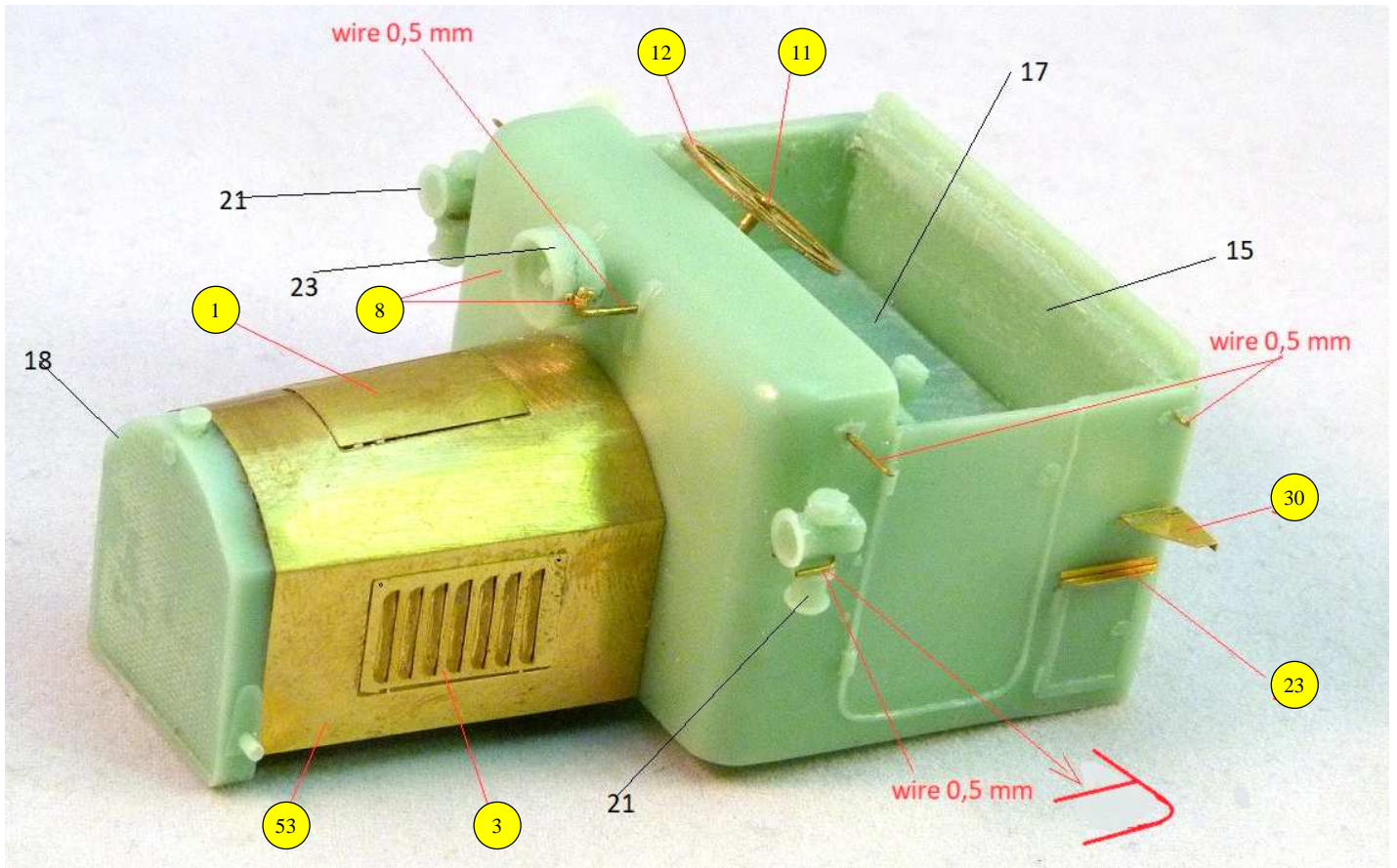
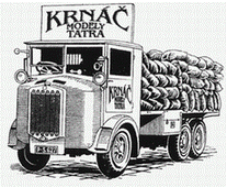

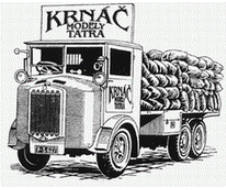

TL-4 OPLEN

1/35

35060

19/32

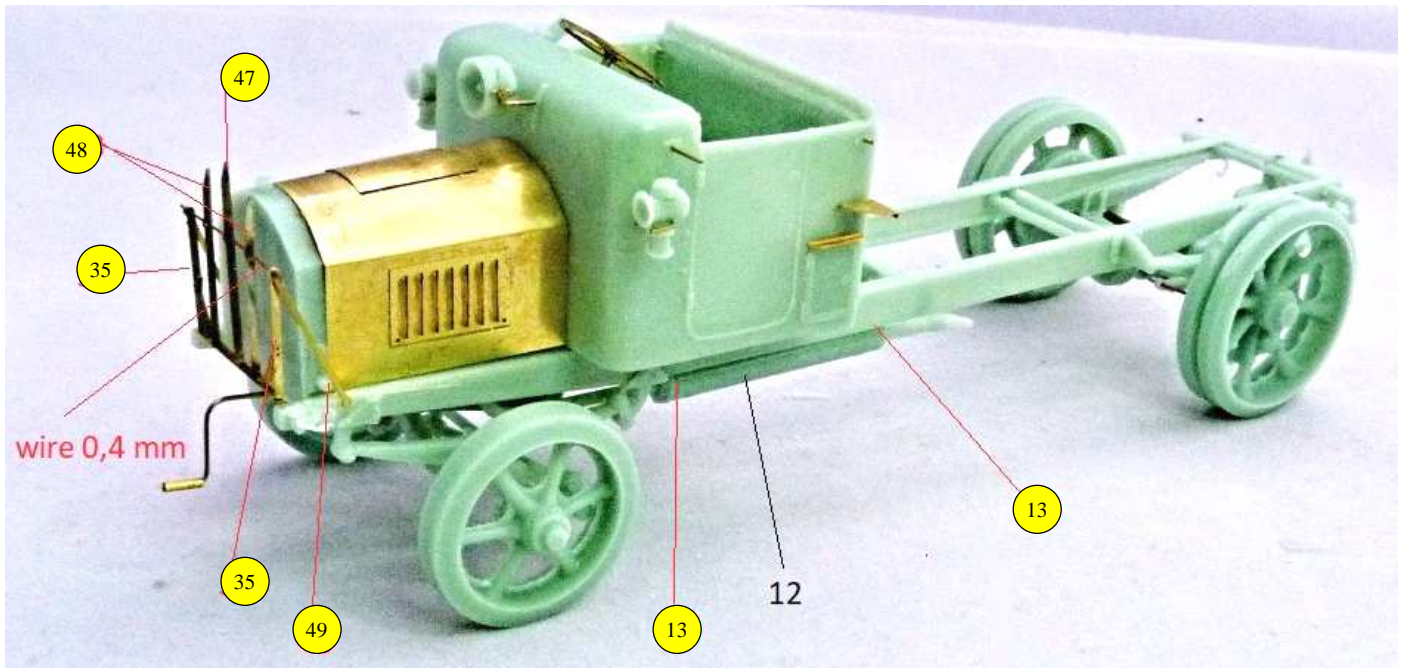

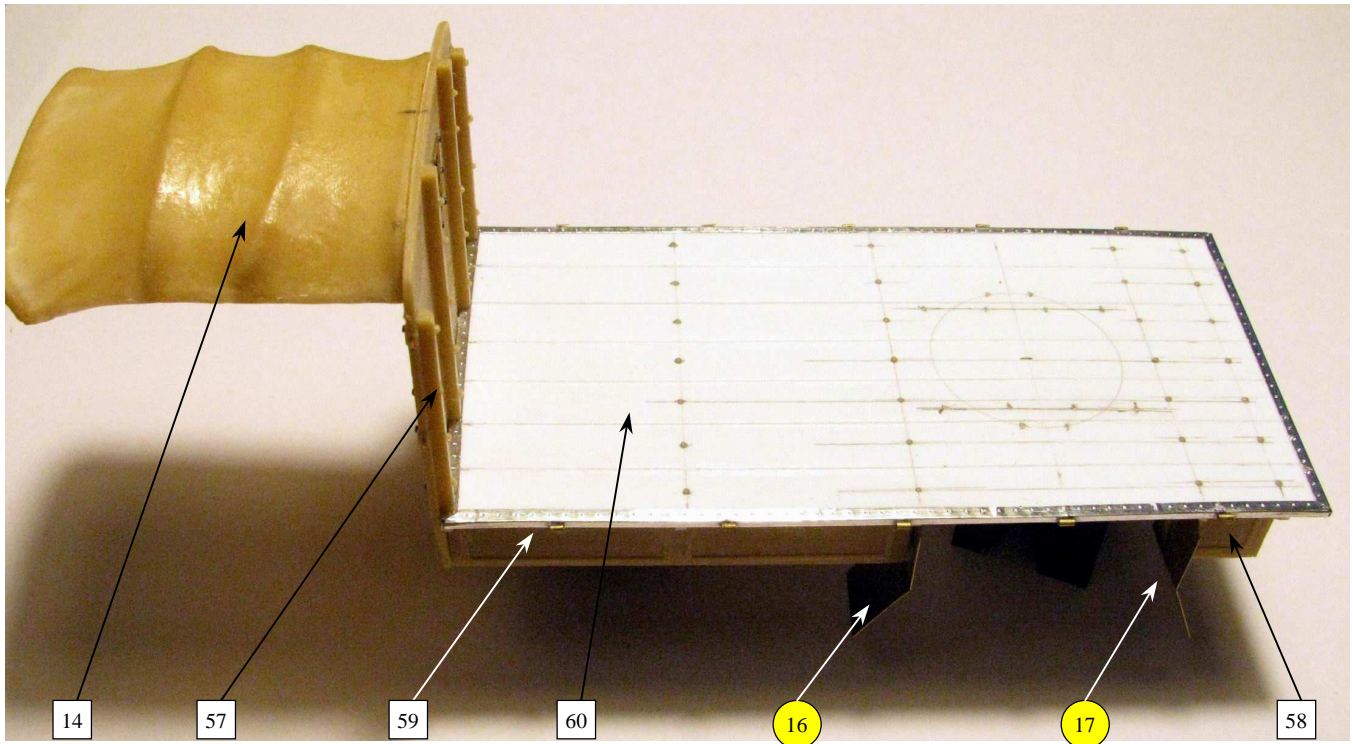
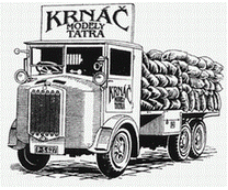

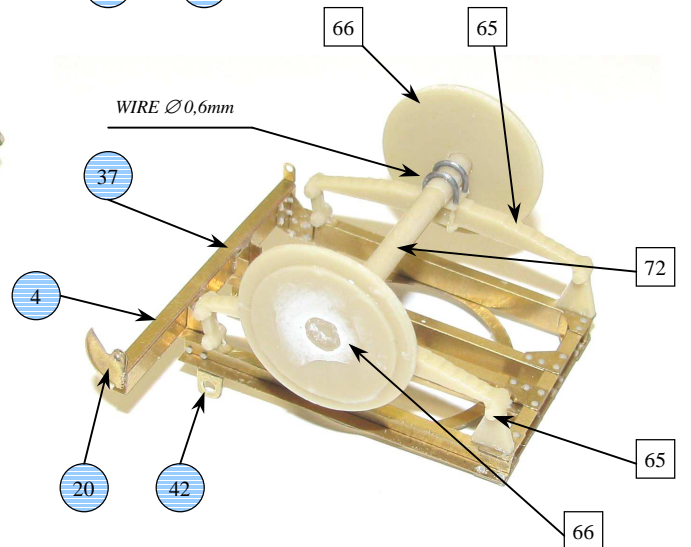
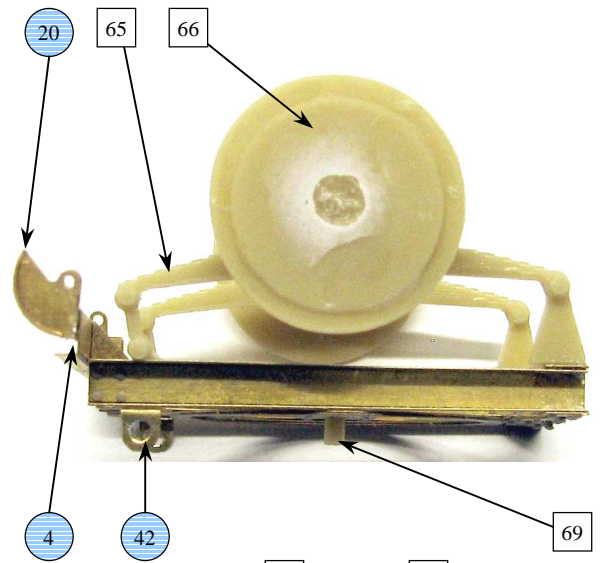
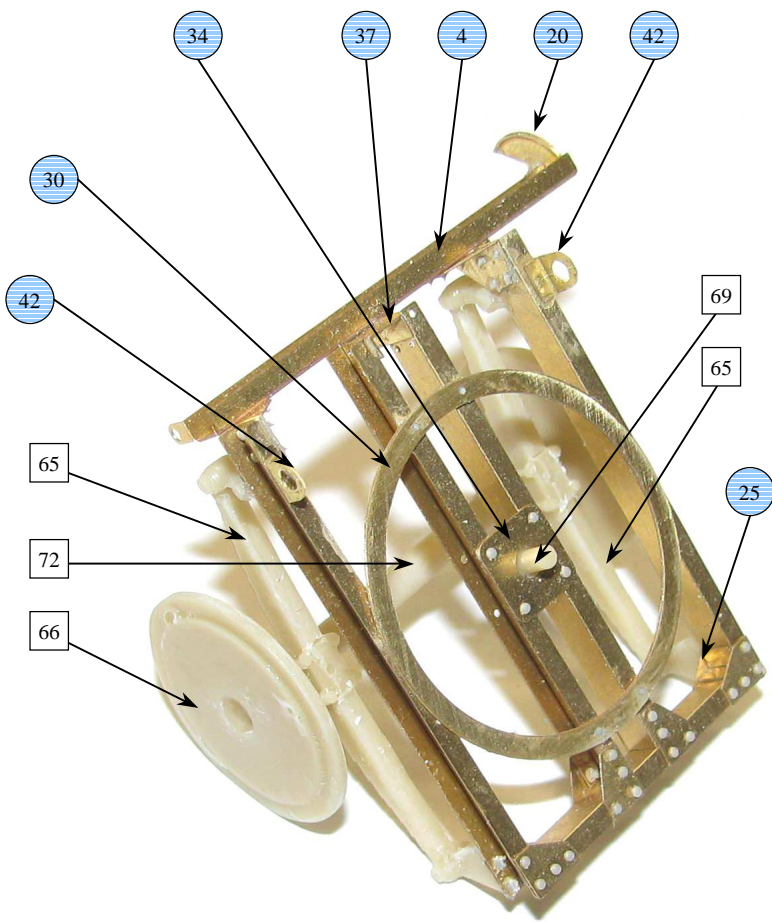
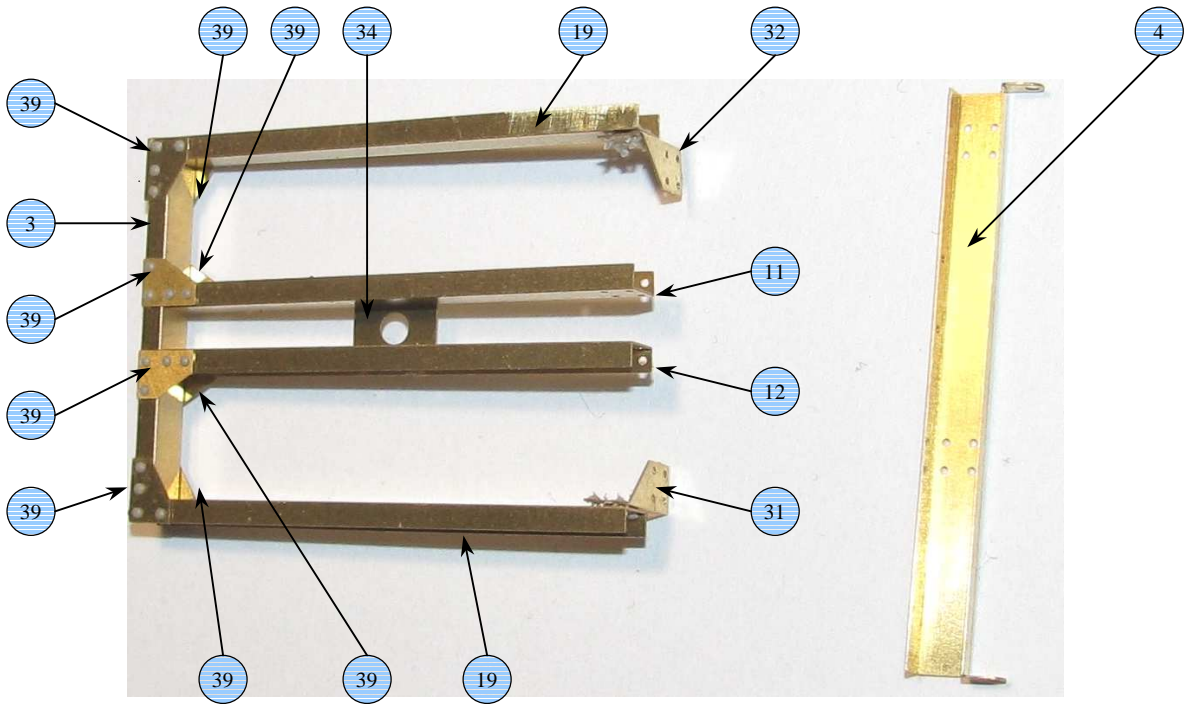

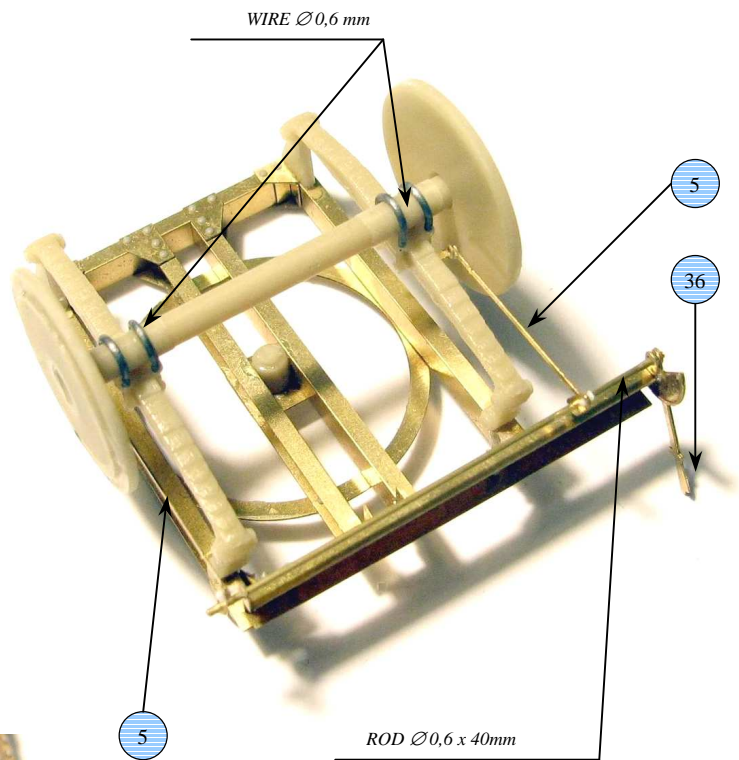
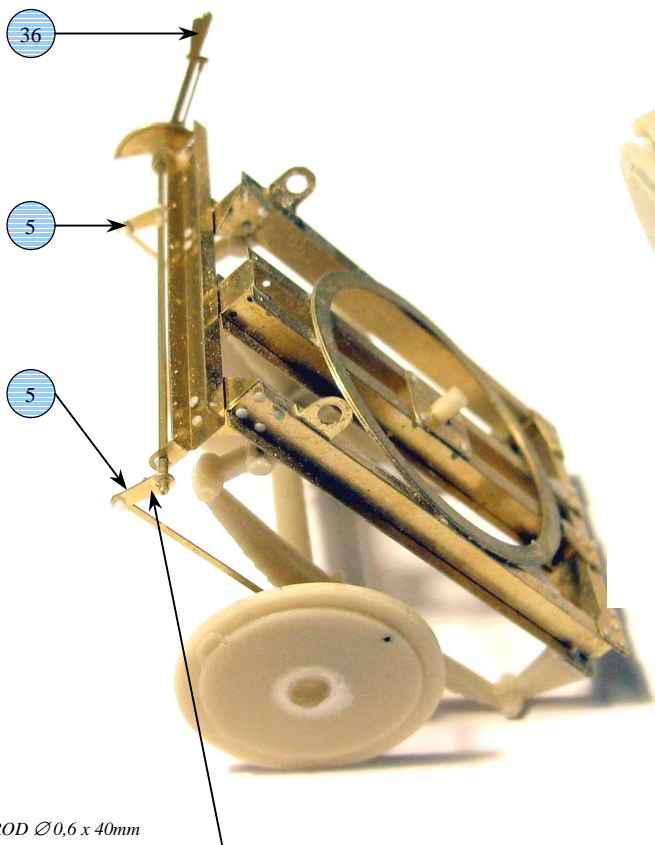
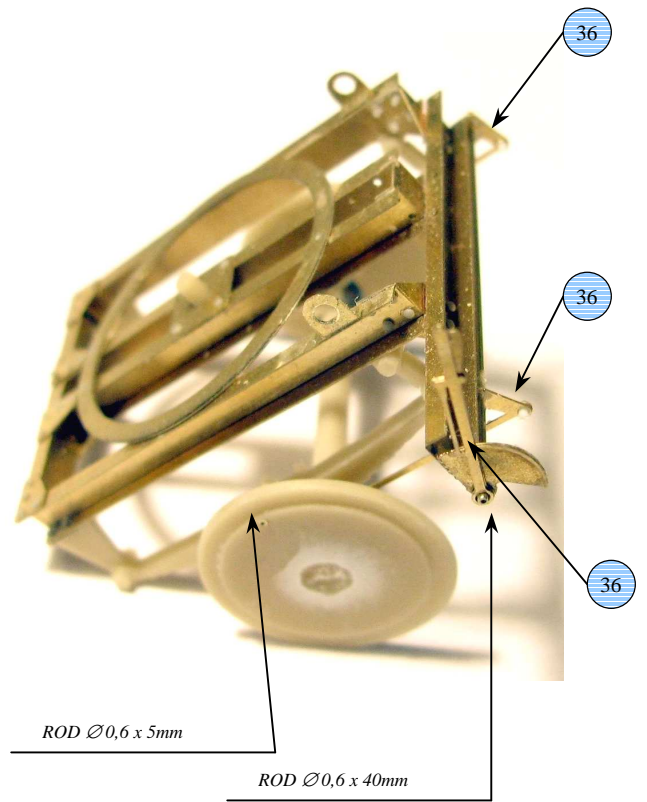
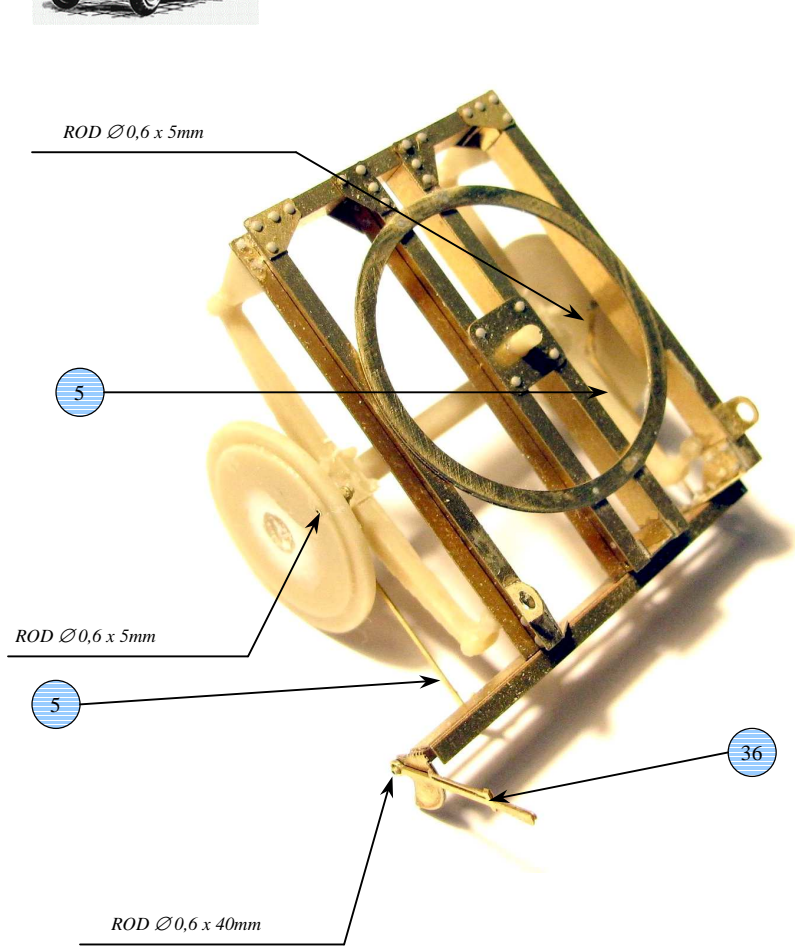
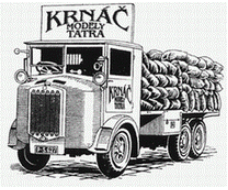

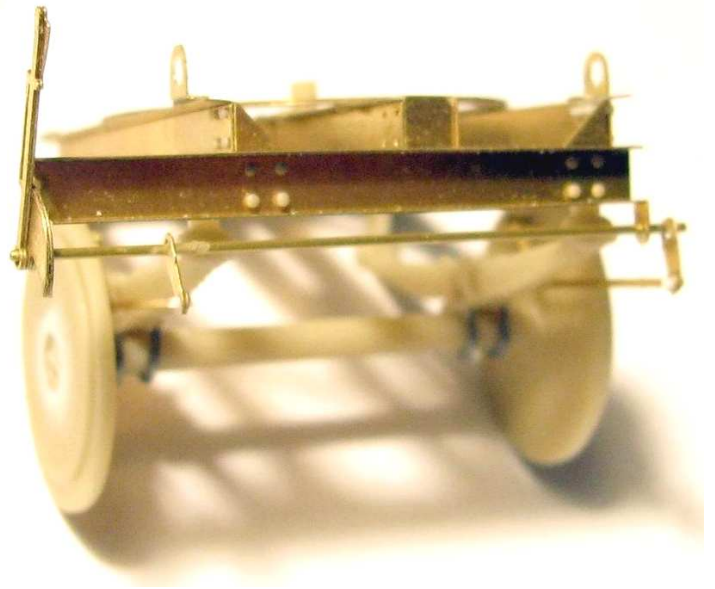
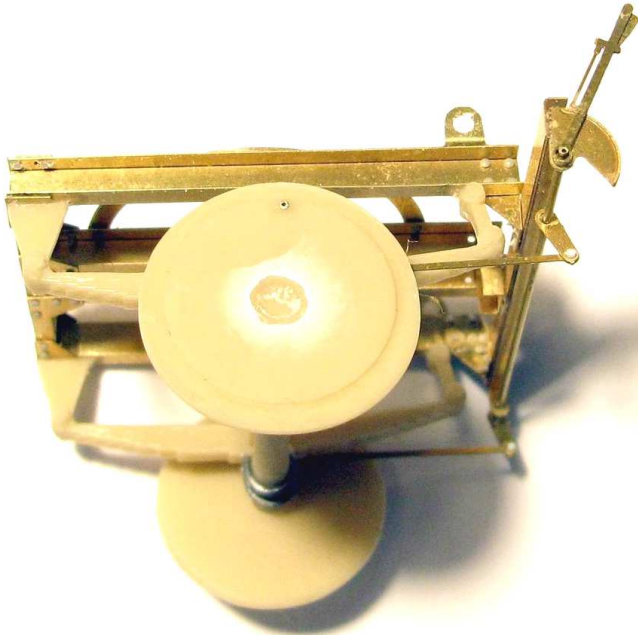
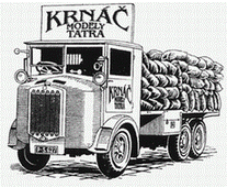

63

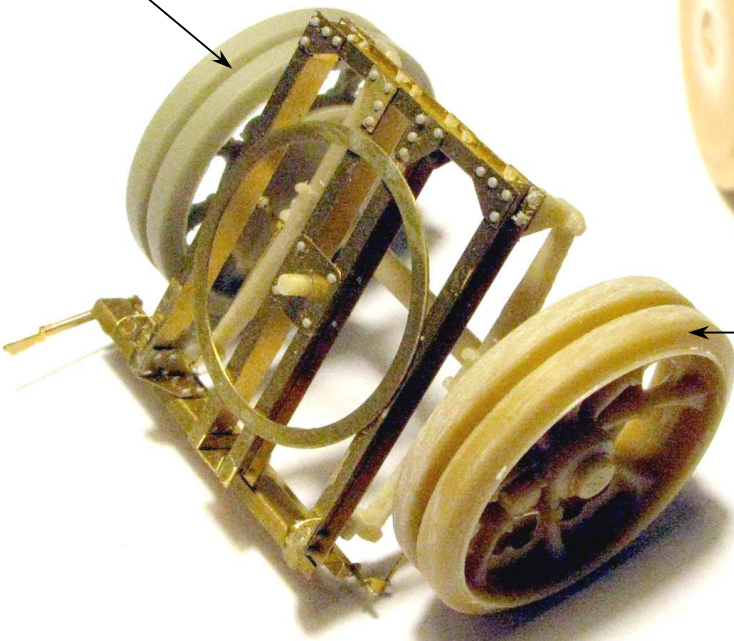

63

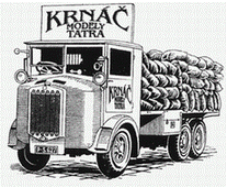

the second girder is mirror-inverted, use the part 14
druhý nosník je zrcadlově obrácený, použij díl č.14

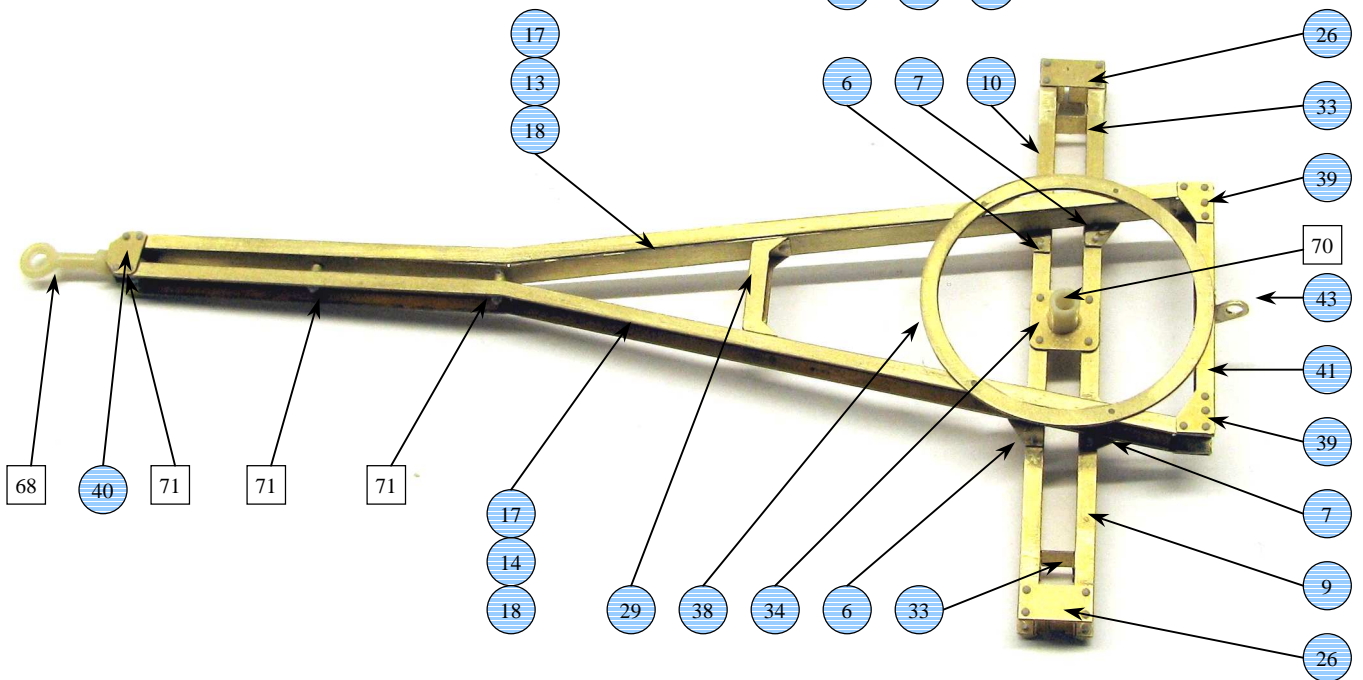
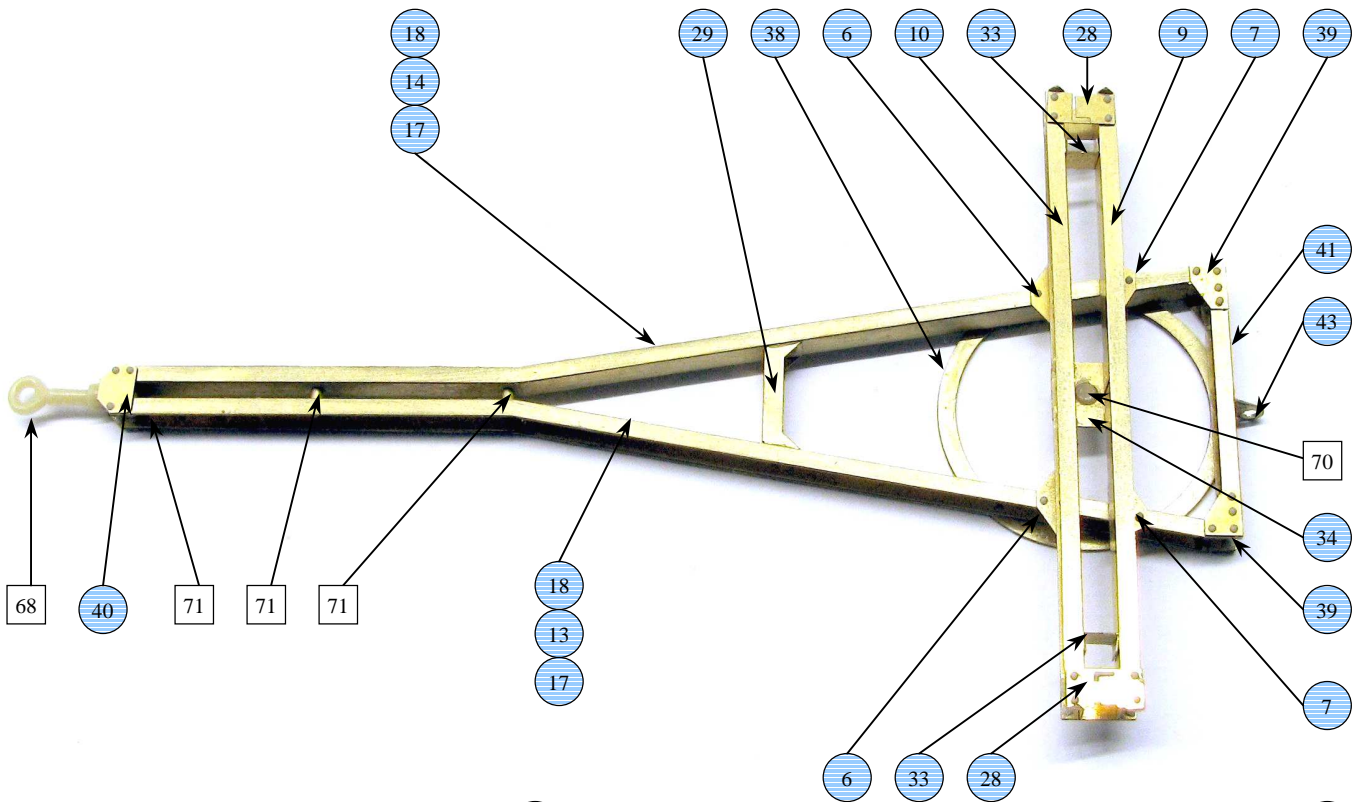
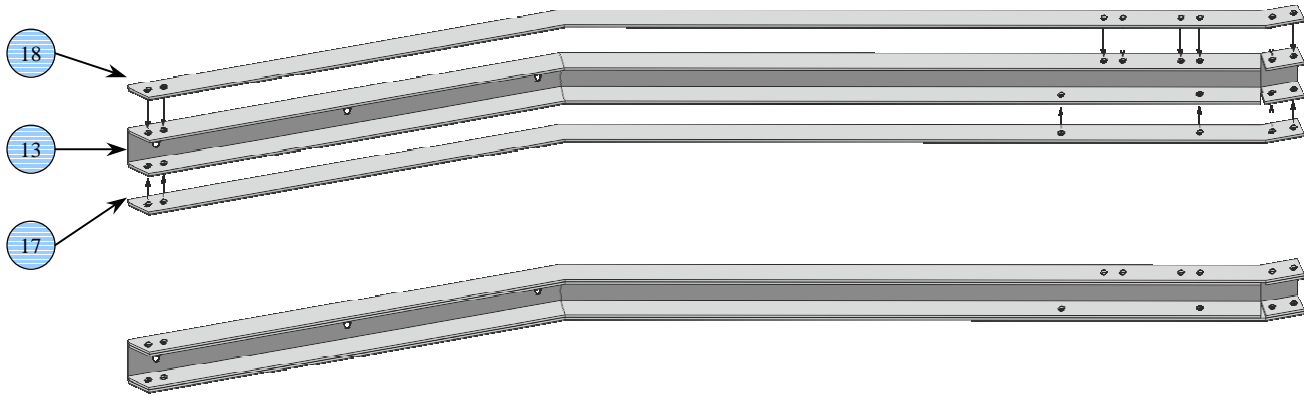

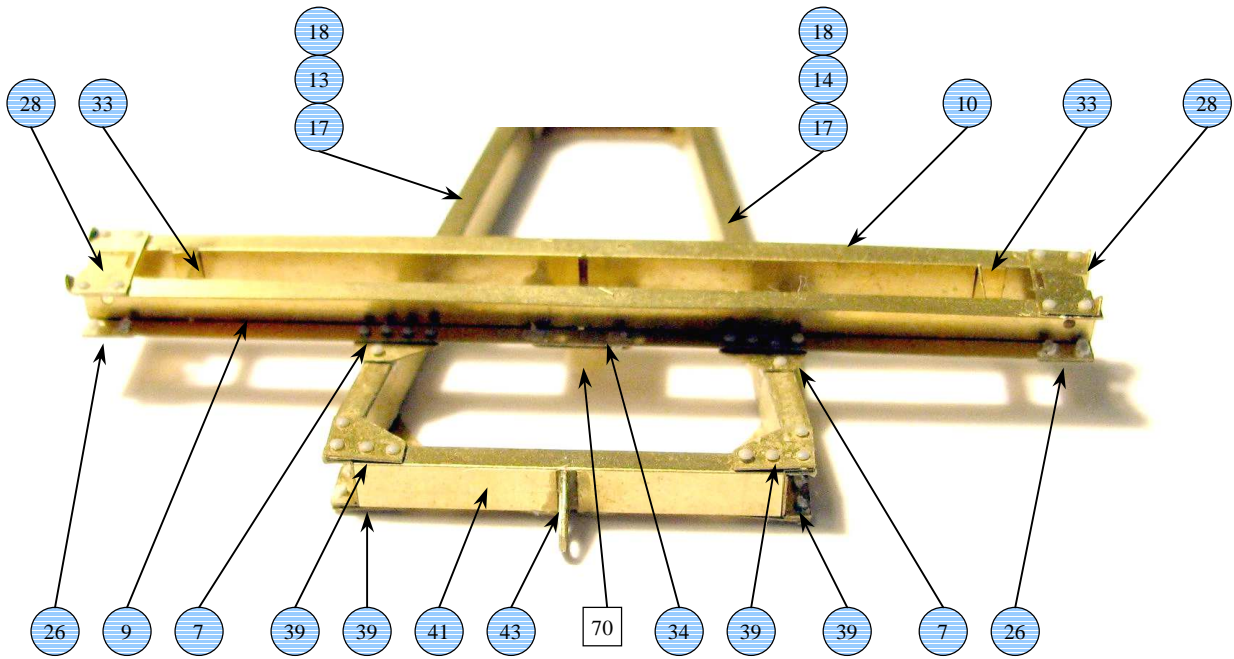
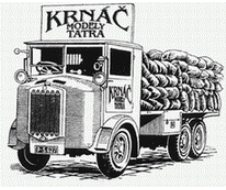

the part 15 is mirror-inverted
díl č.15 je zrcadlově obrácený

23

STEP 1



STEP 2



STEP 3



STEP 4



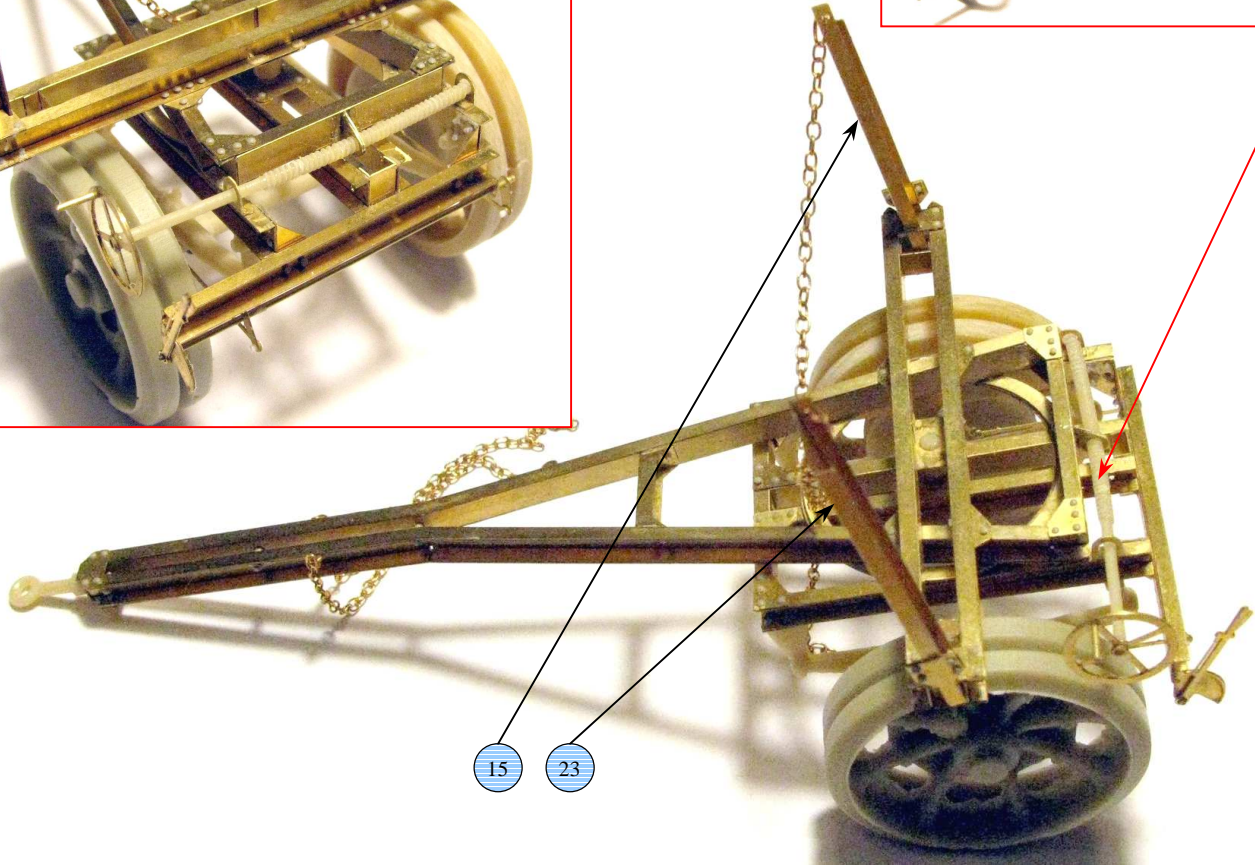
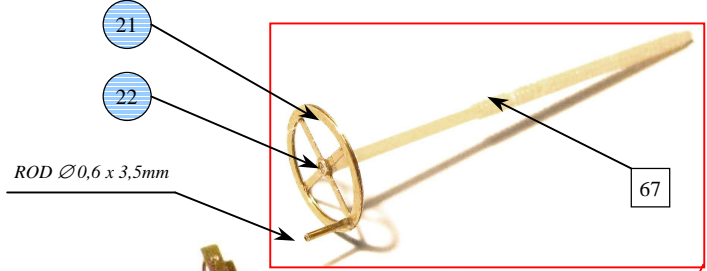
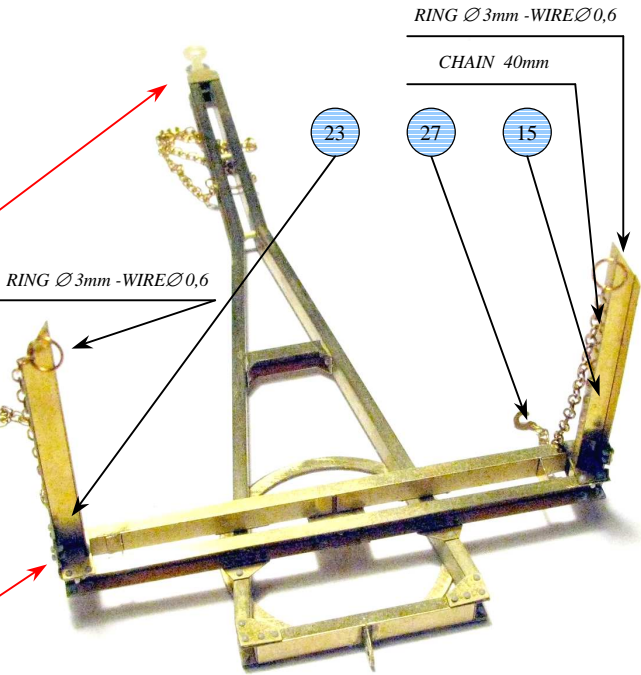
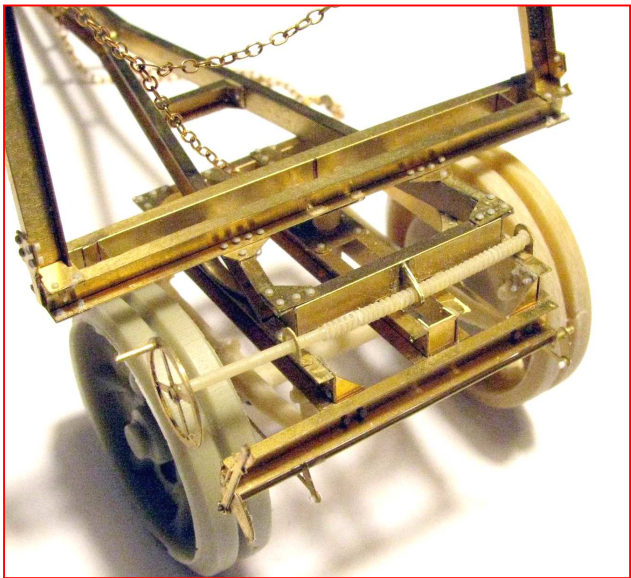
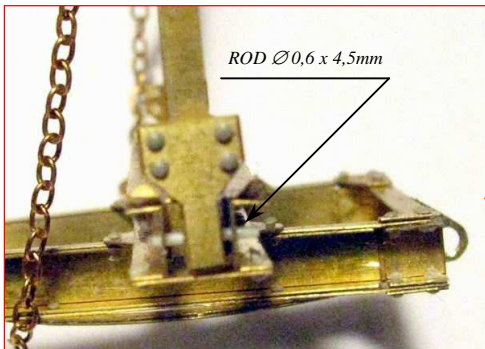
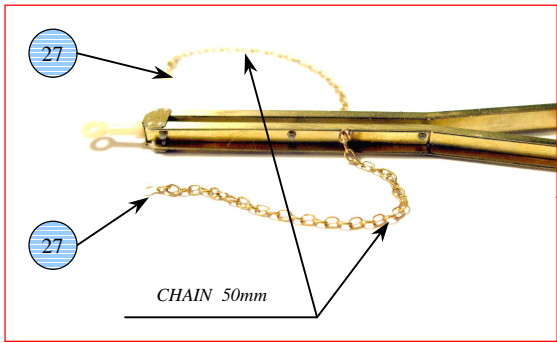
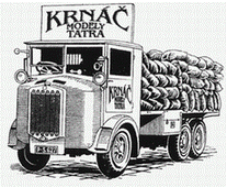

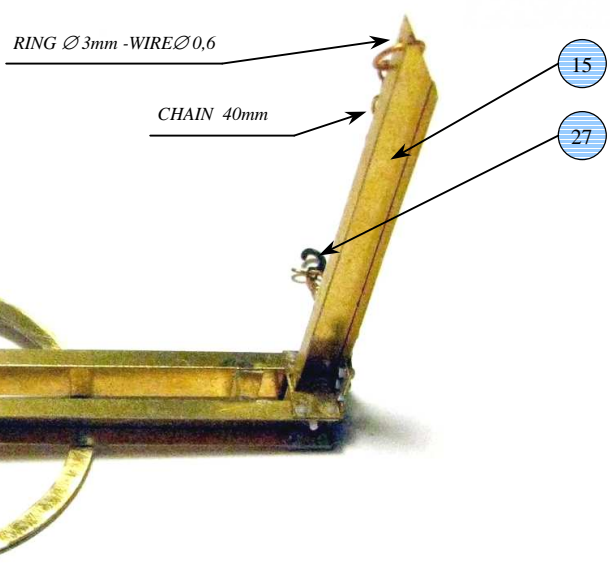
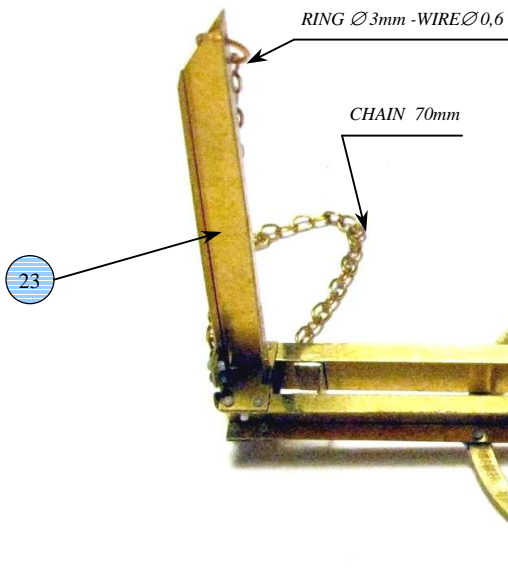
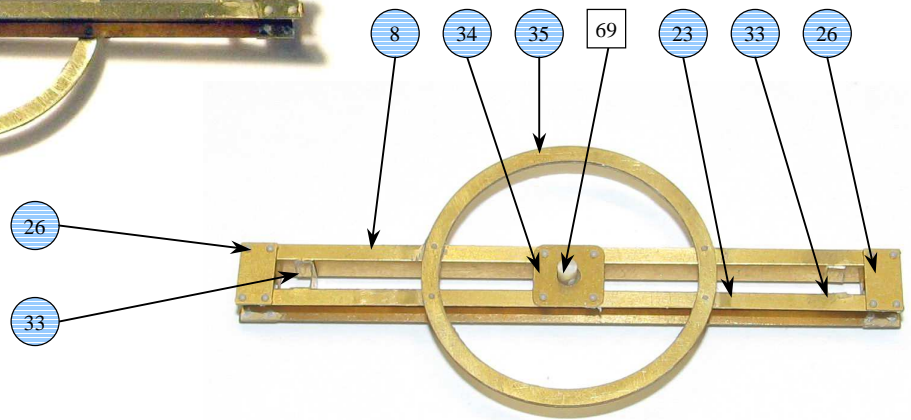
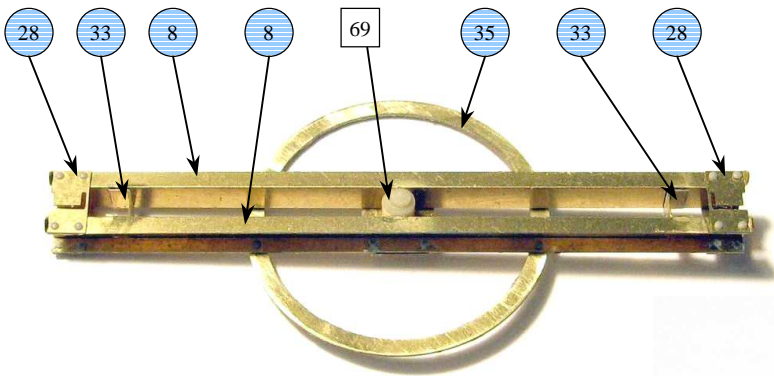
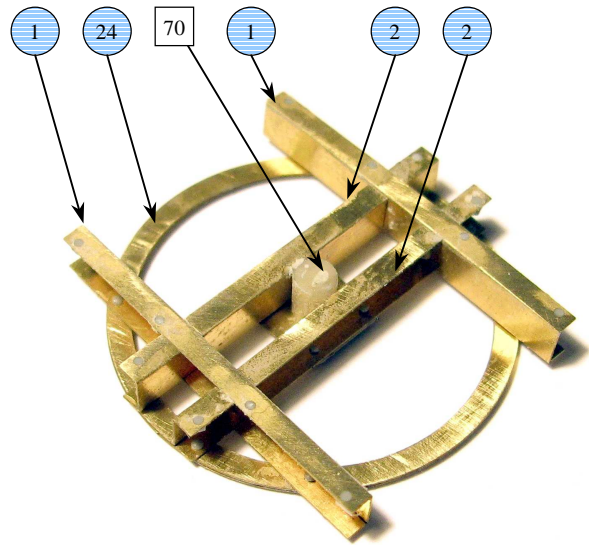
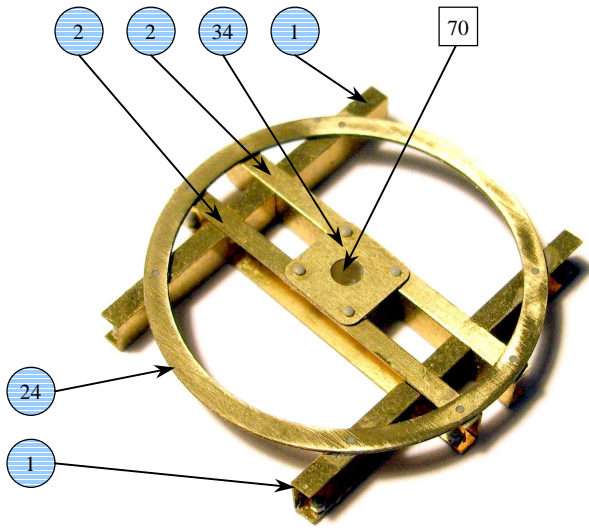
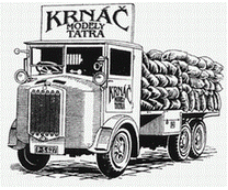

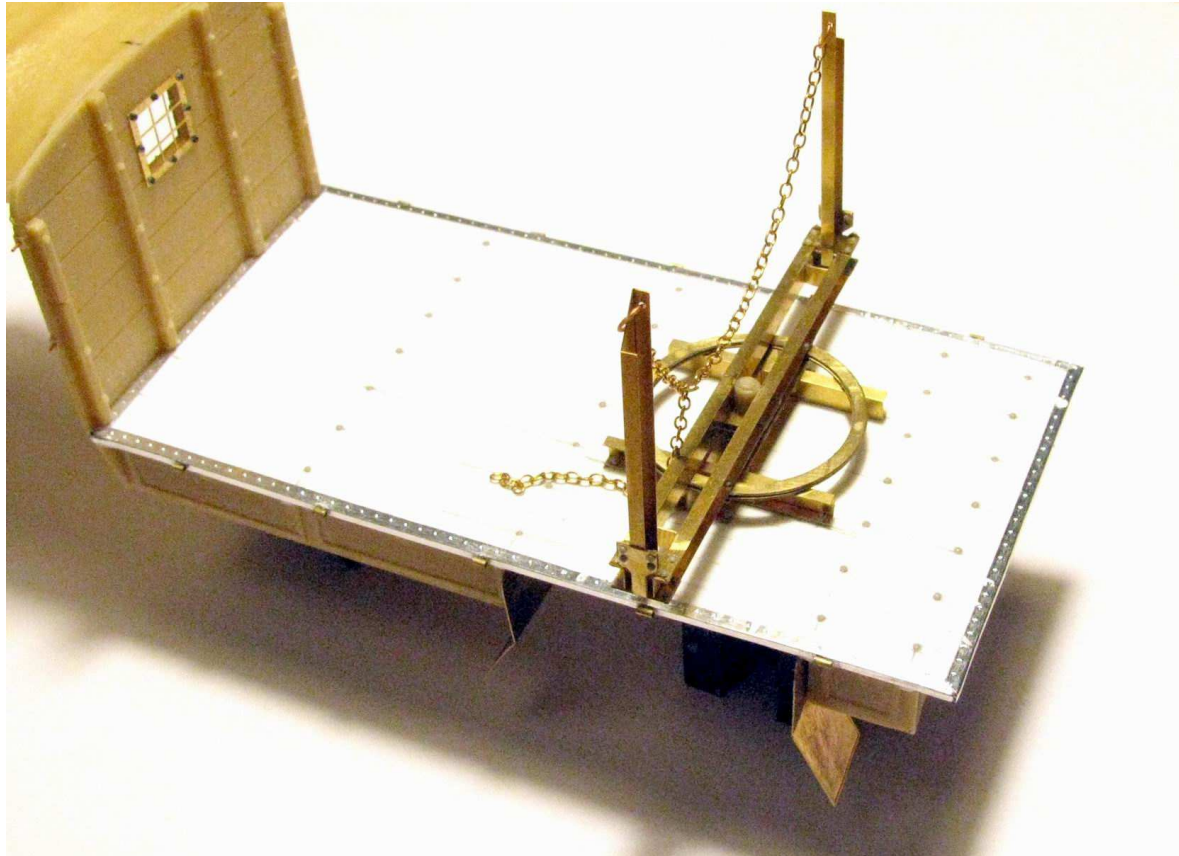
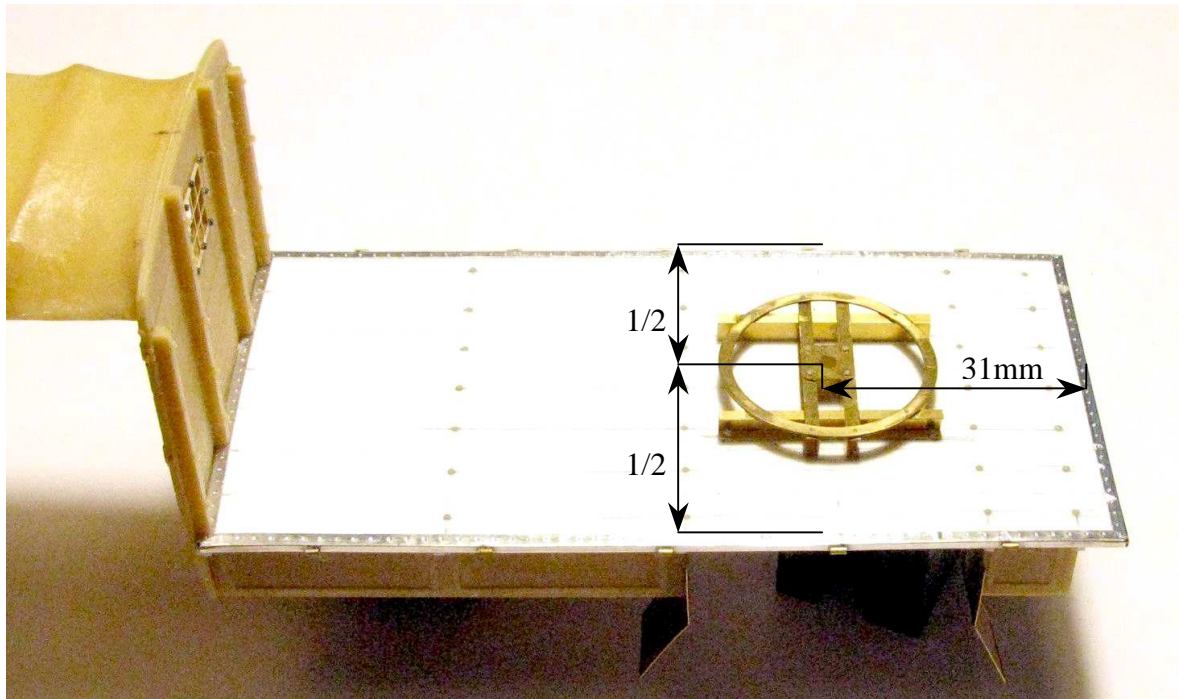
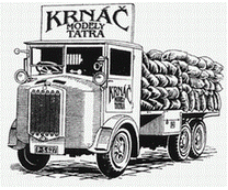



TL-4 OPLEN

1/35

35060

29/32

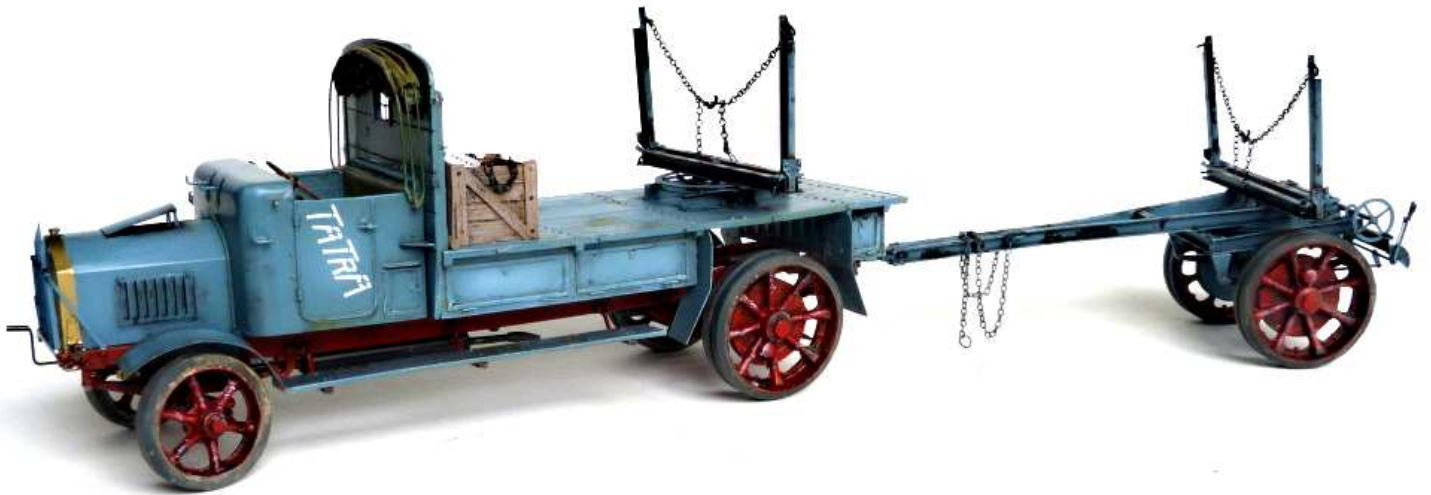

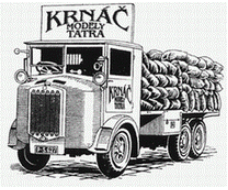

TL-4 OPLEN

1/35

35060

30/32

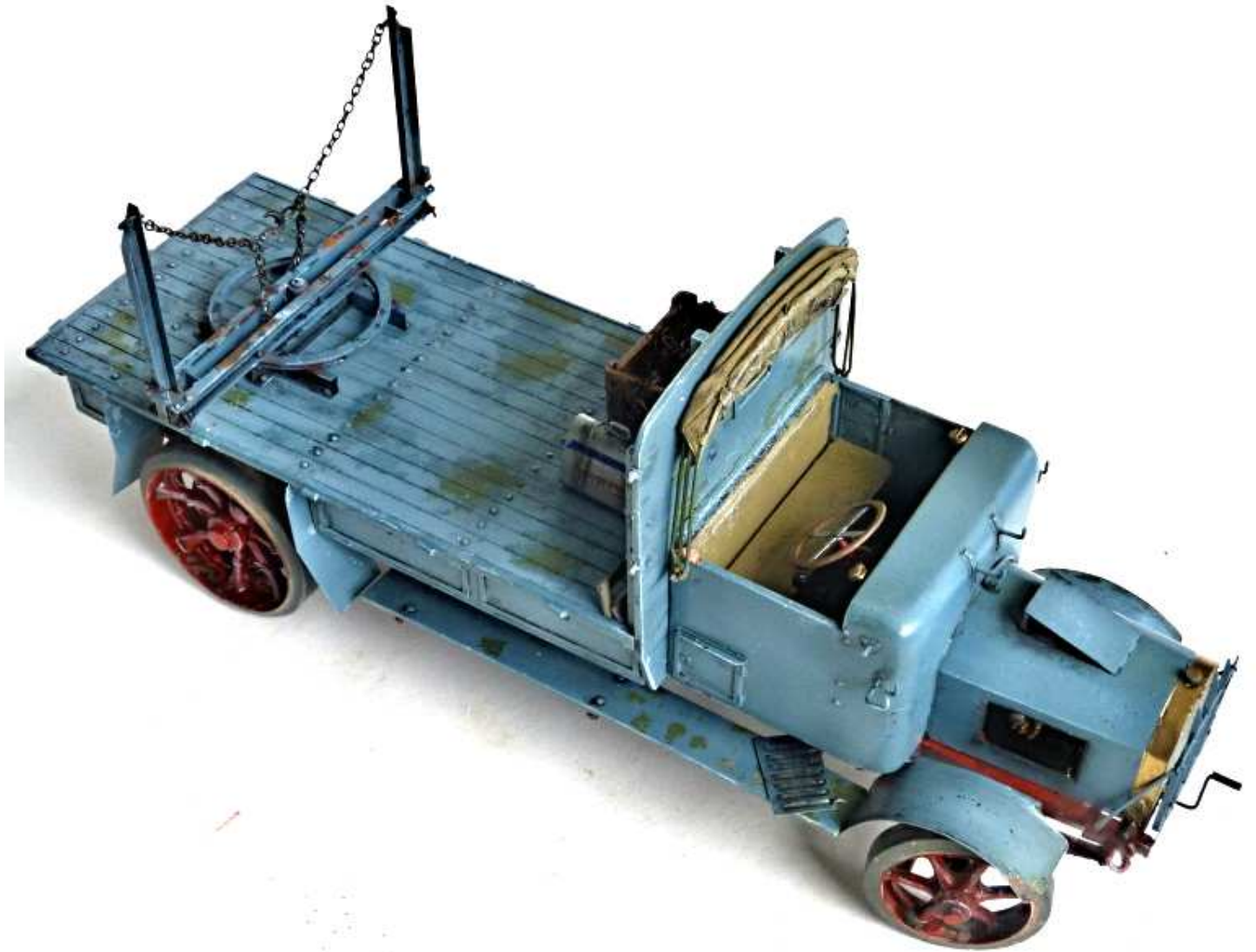

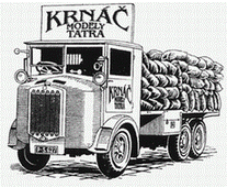

TL-4 OPLEN

1/35

35060

31/32

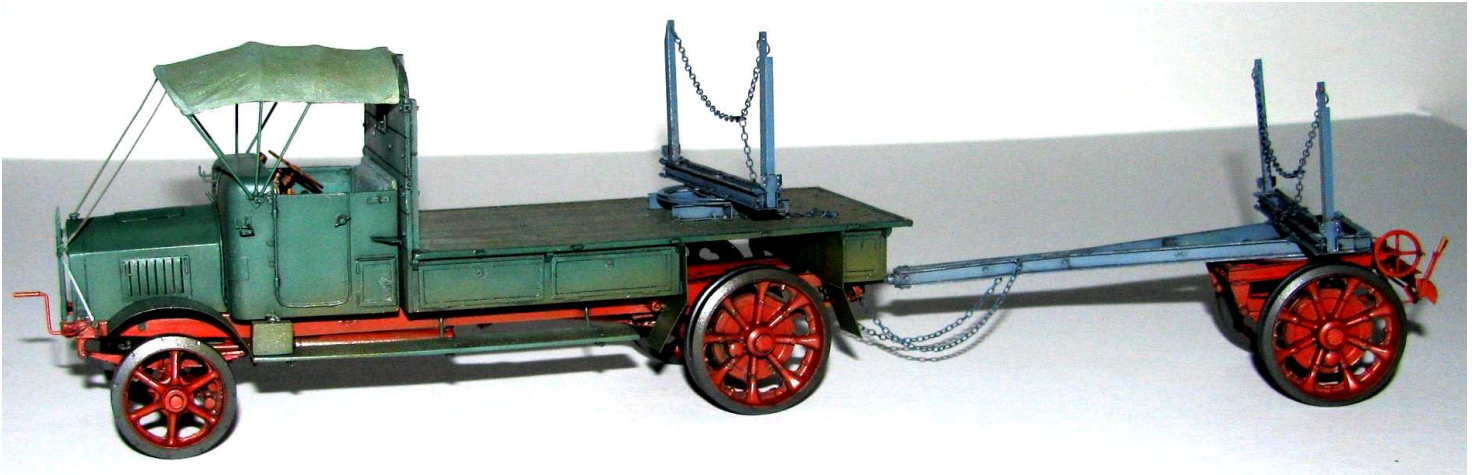

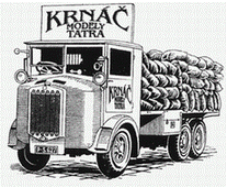

TL-4 OPLEN

1/35

35060

32/32

