

48

52

50

53

51

49



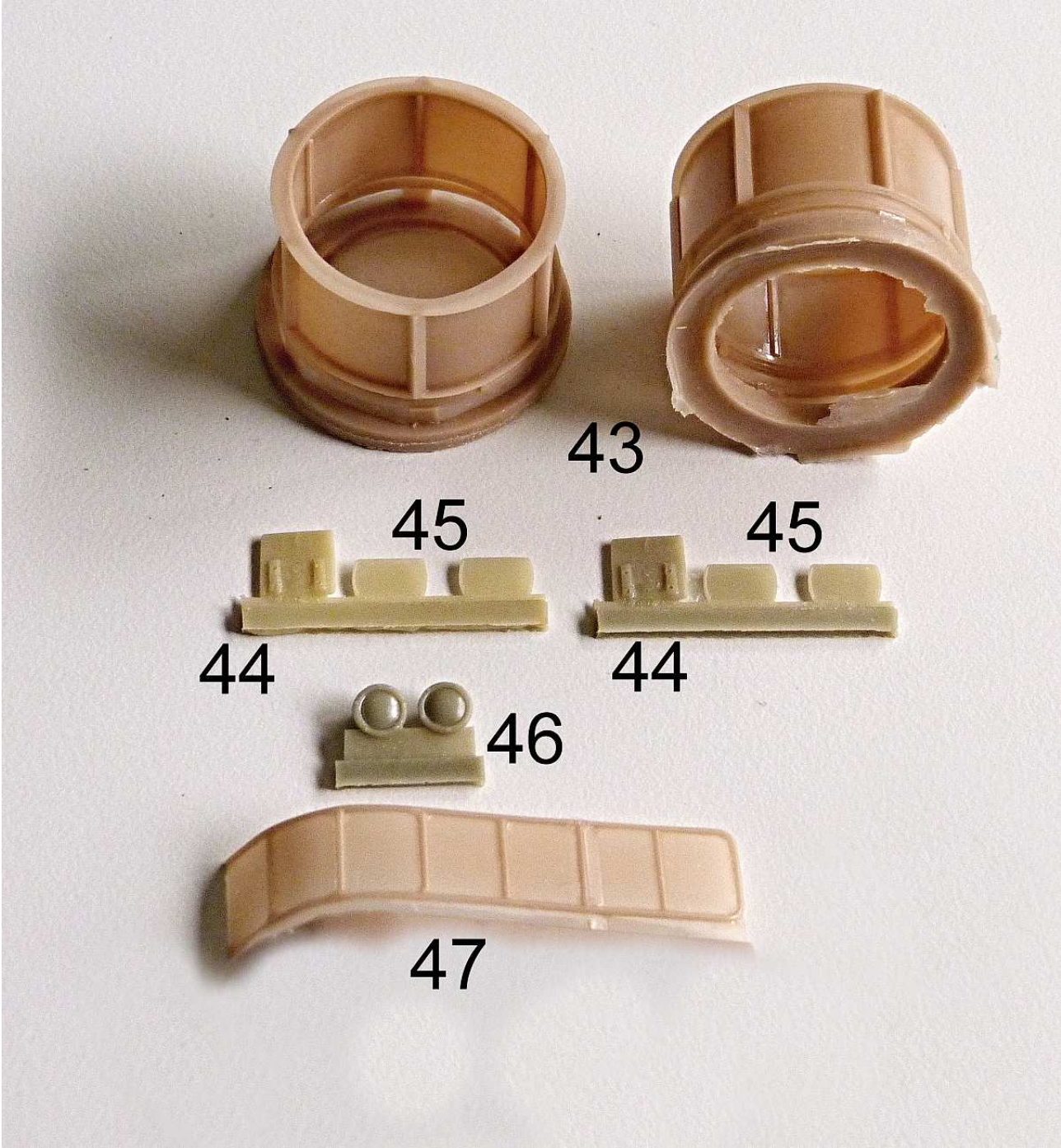

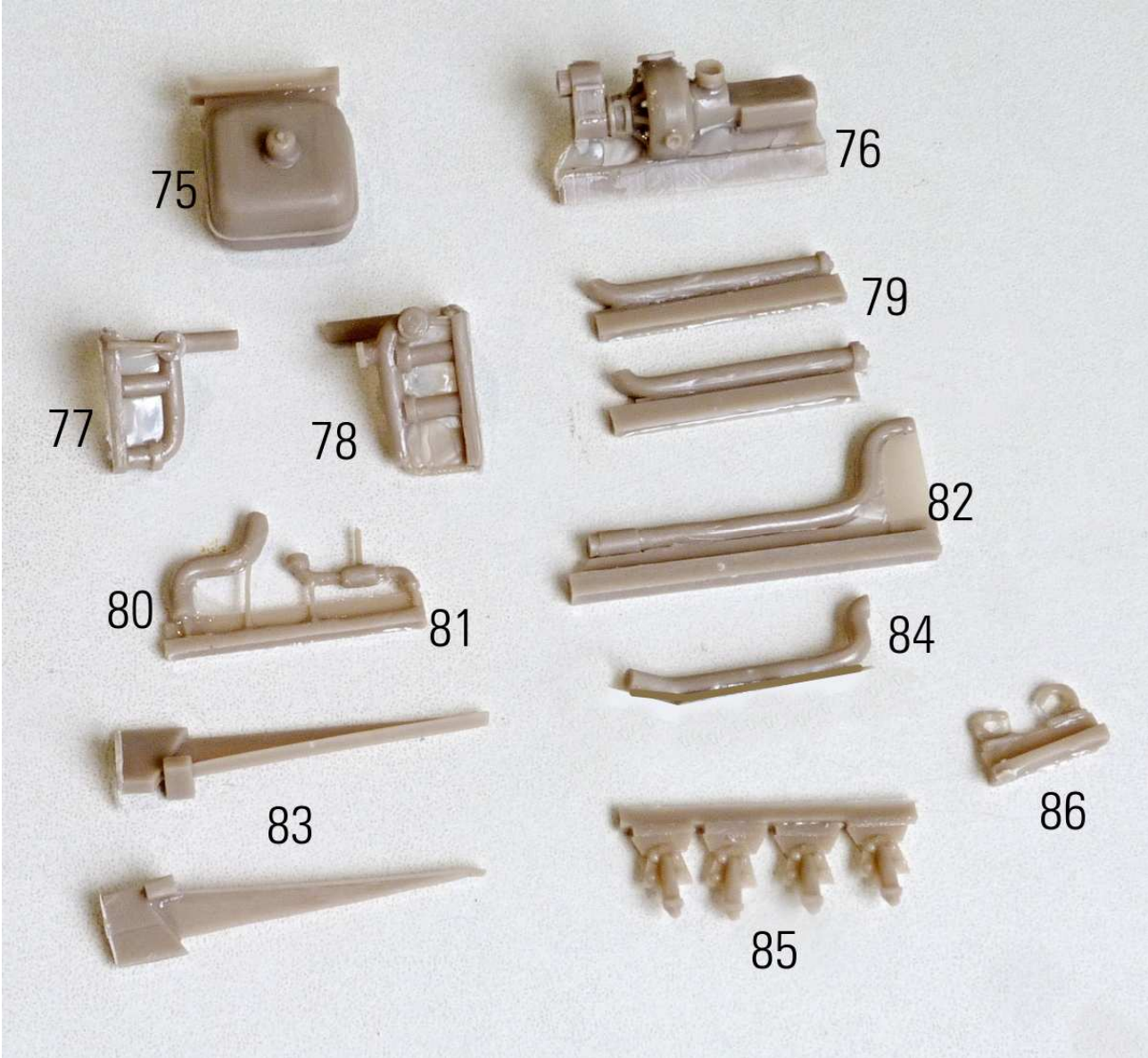



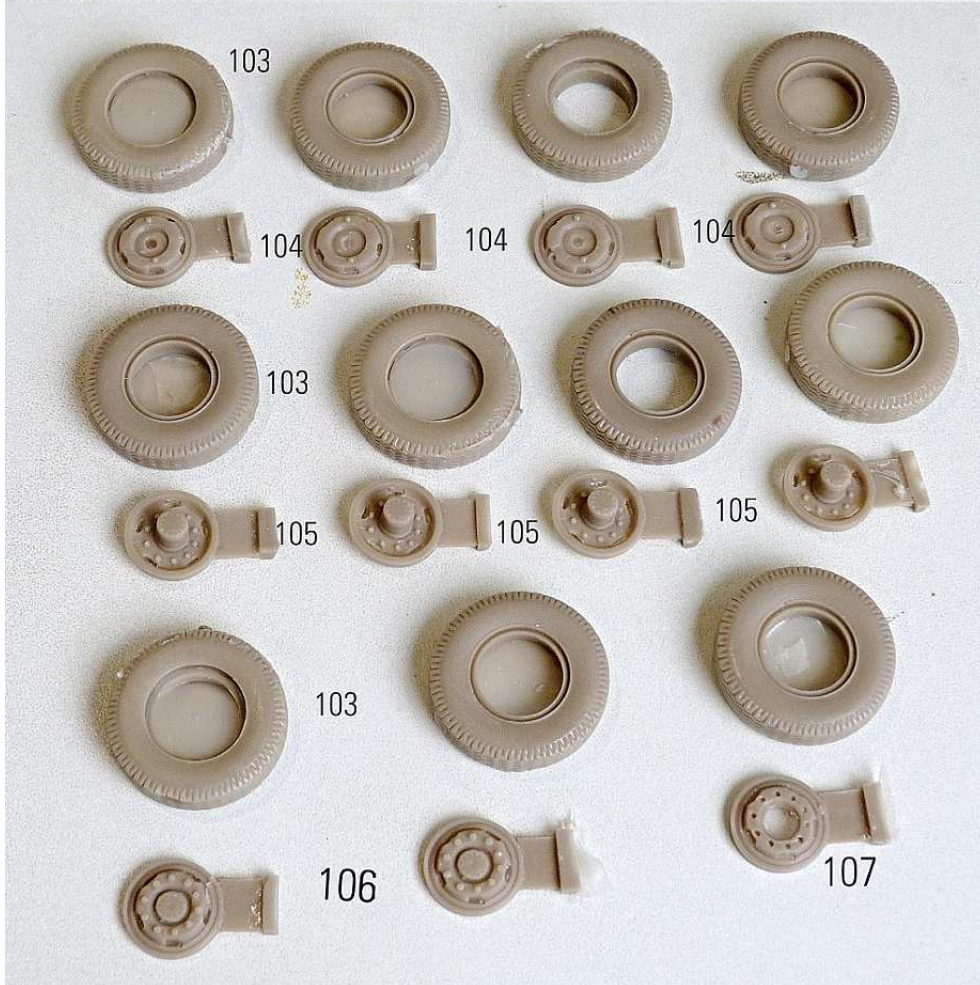

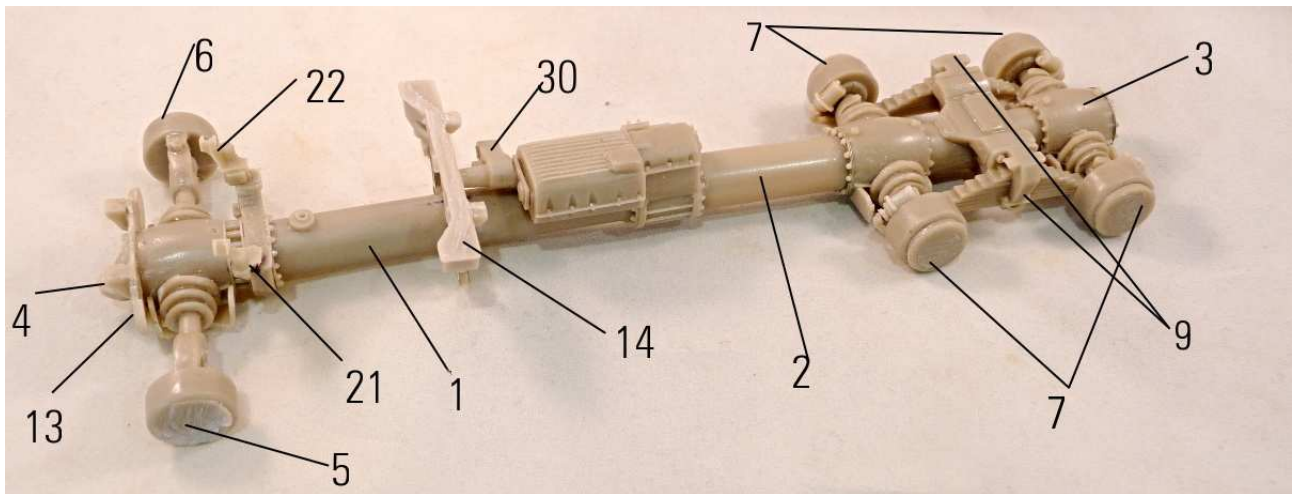
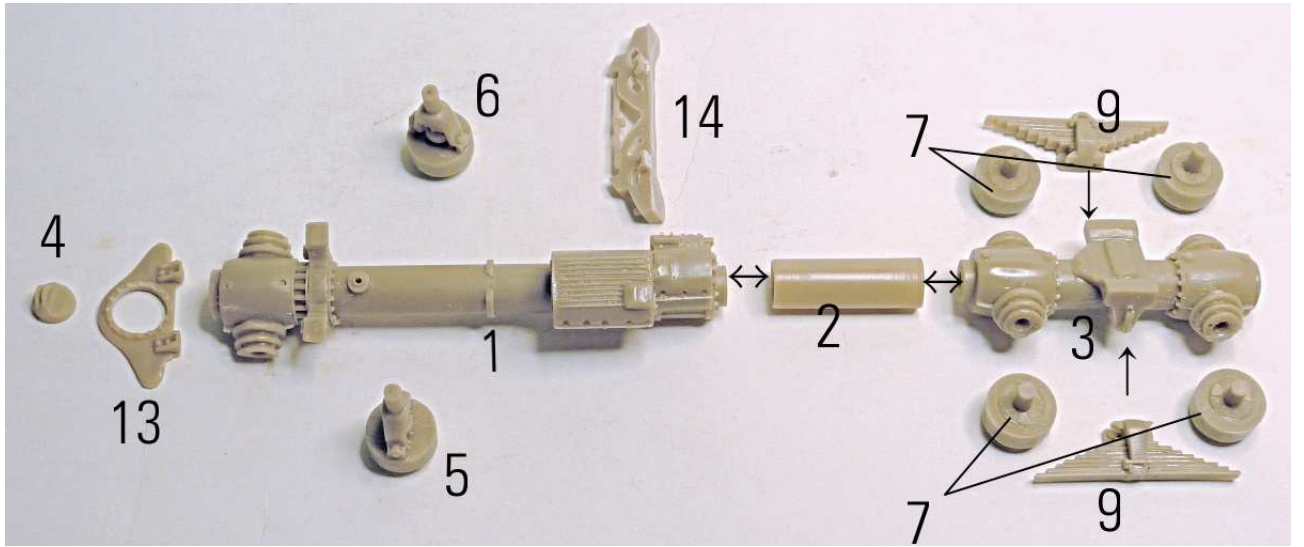



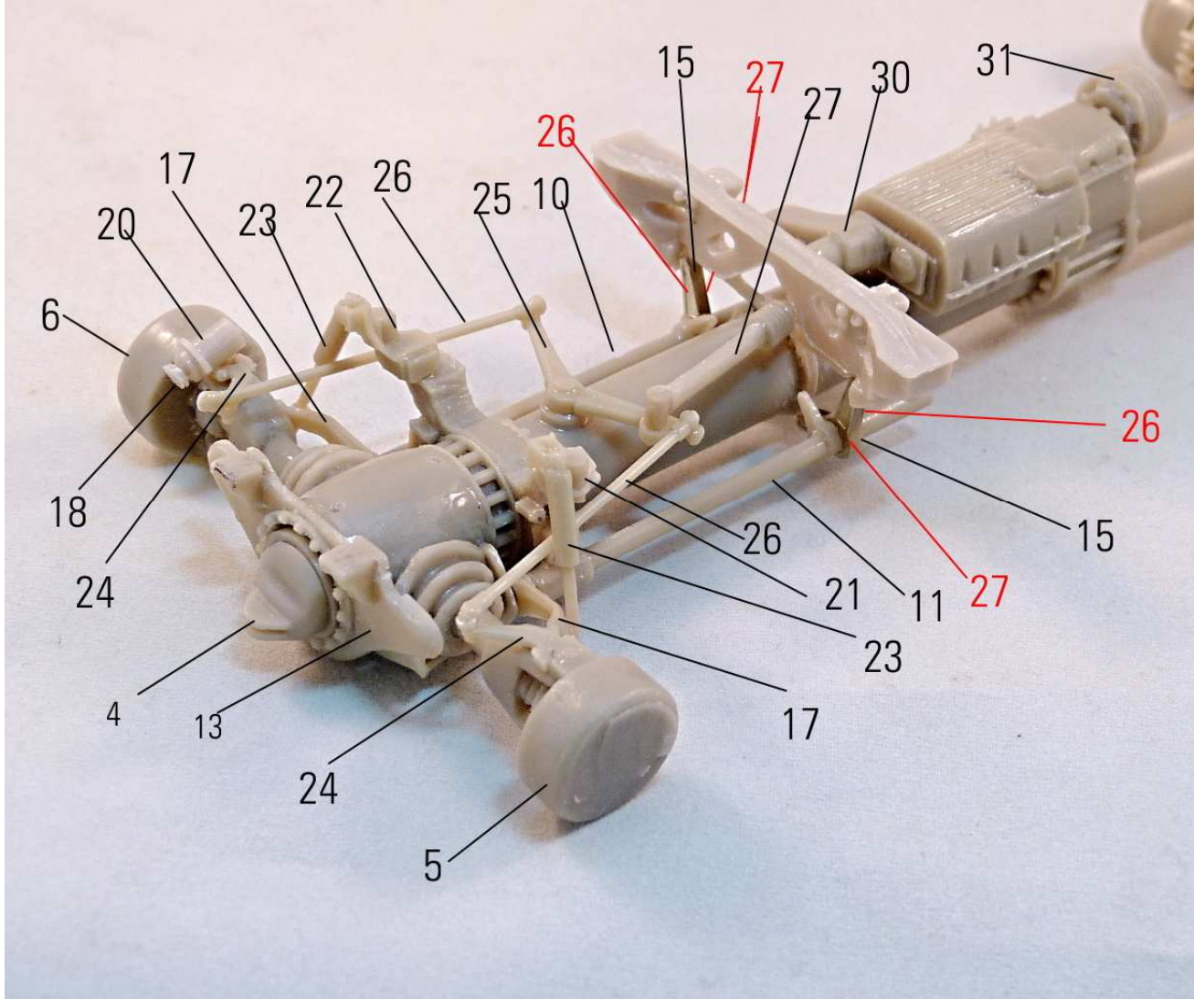
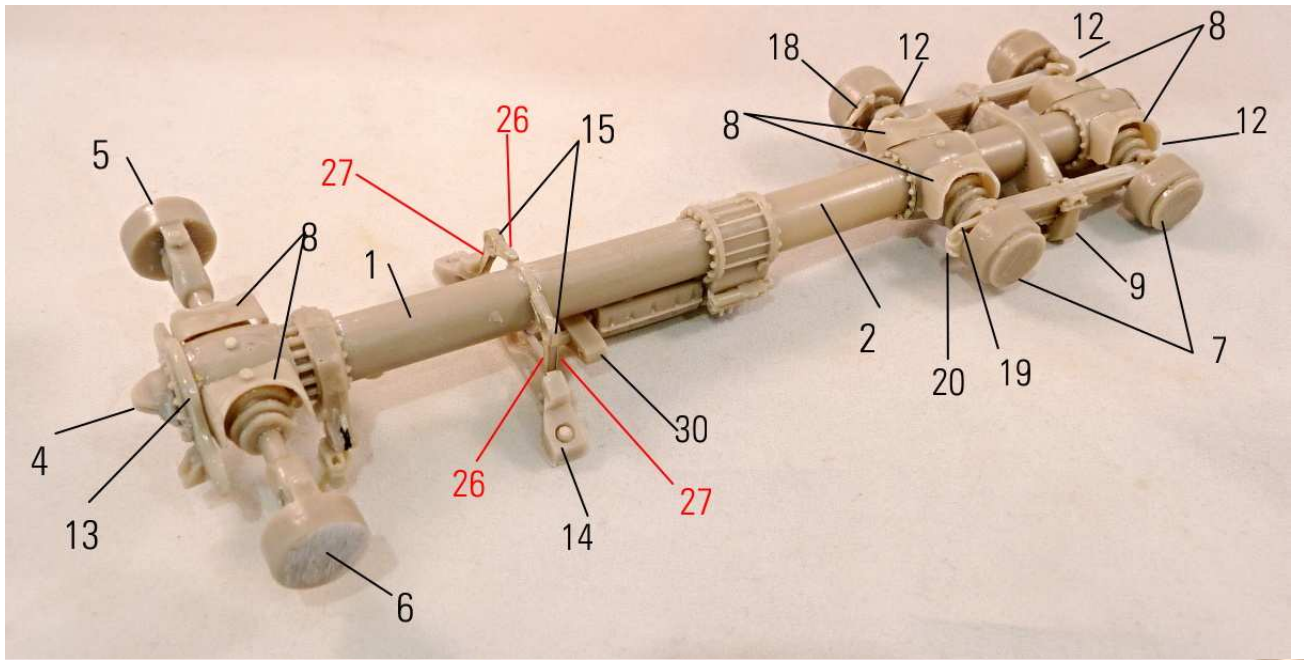

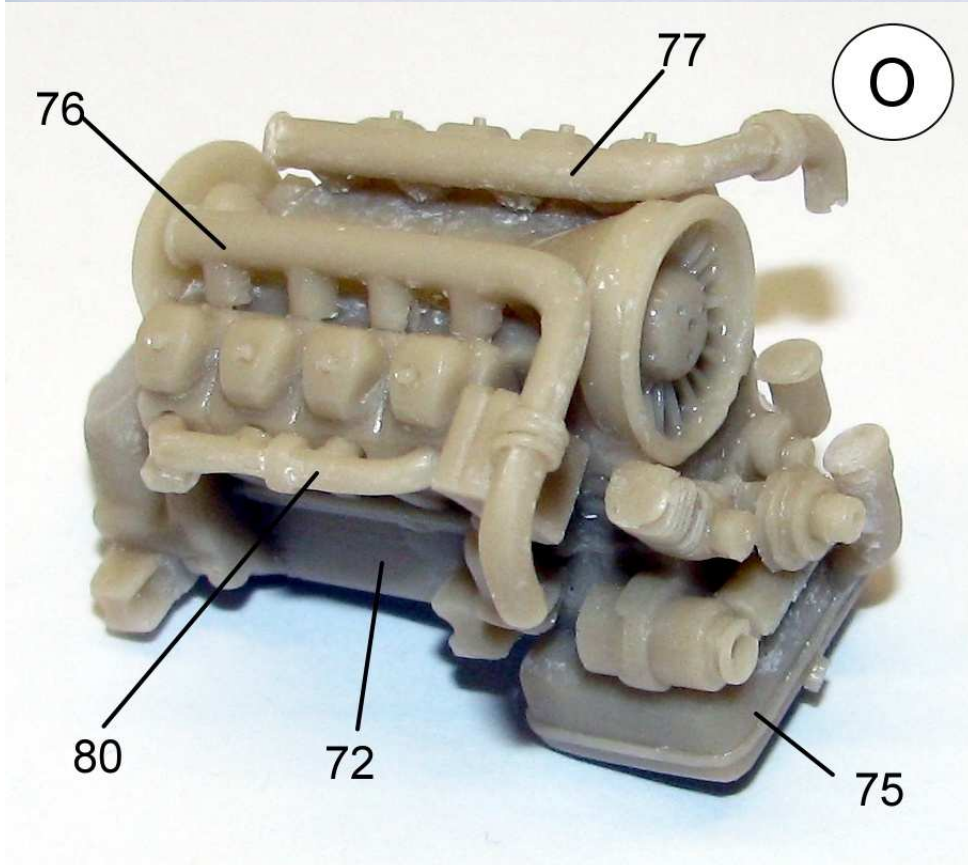
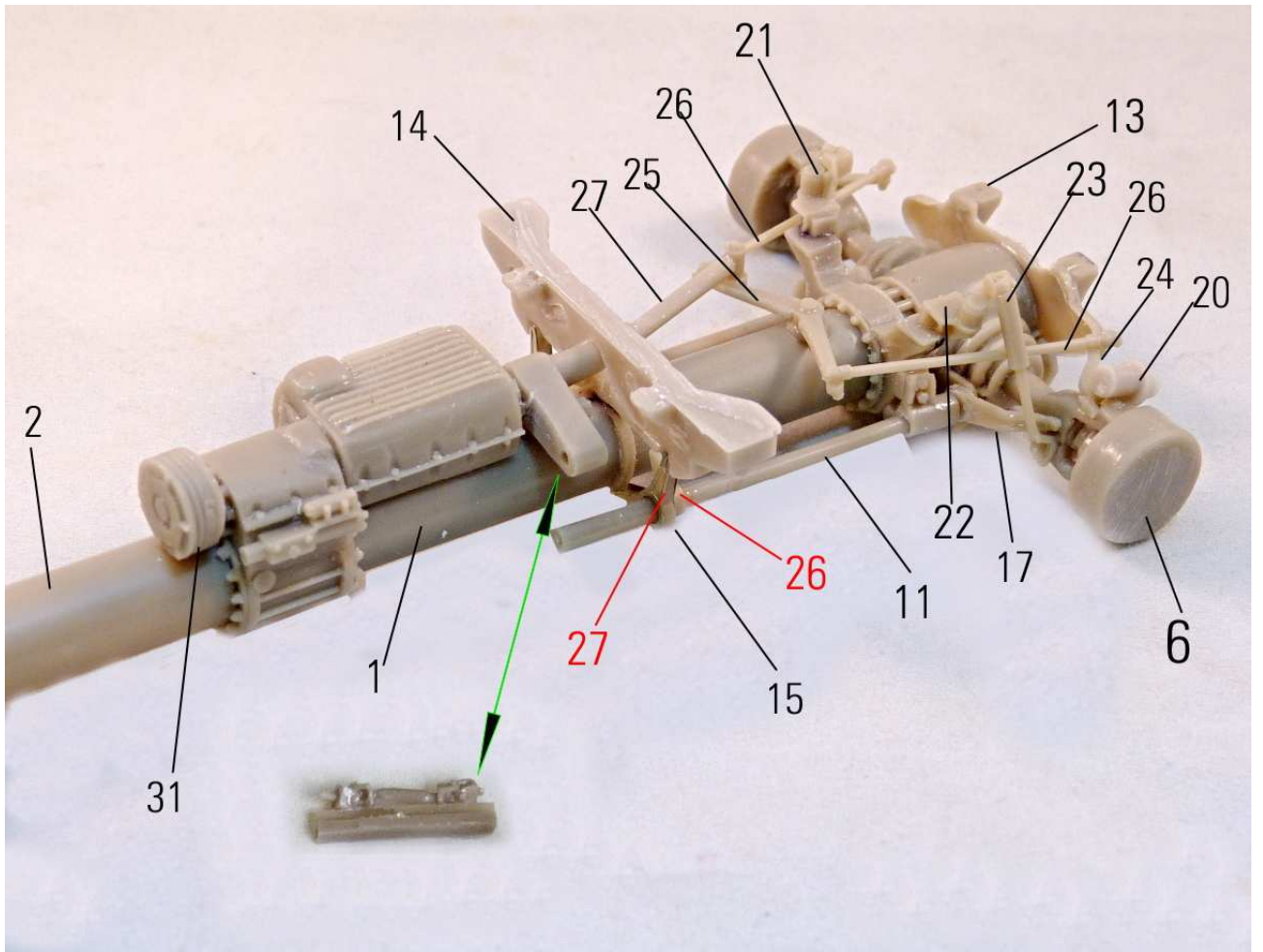



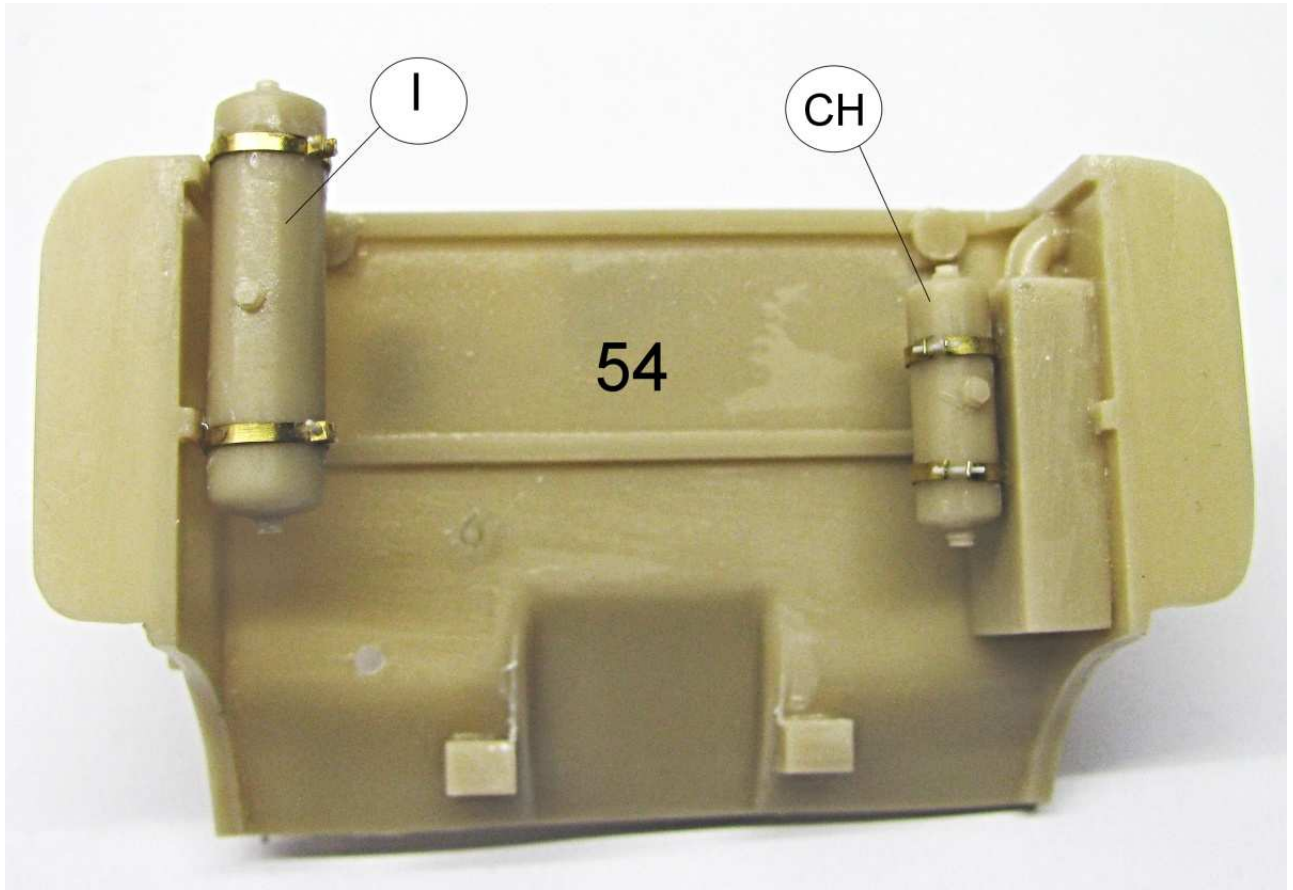
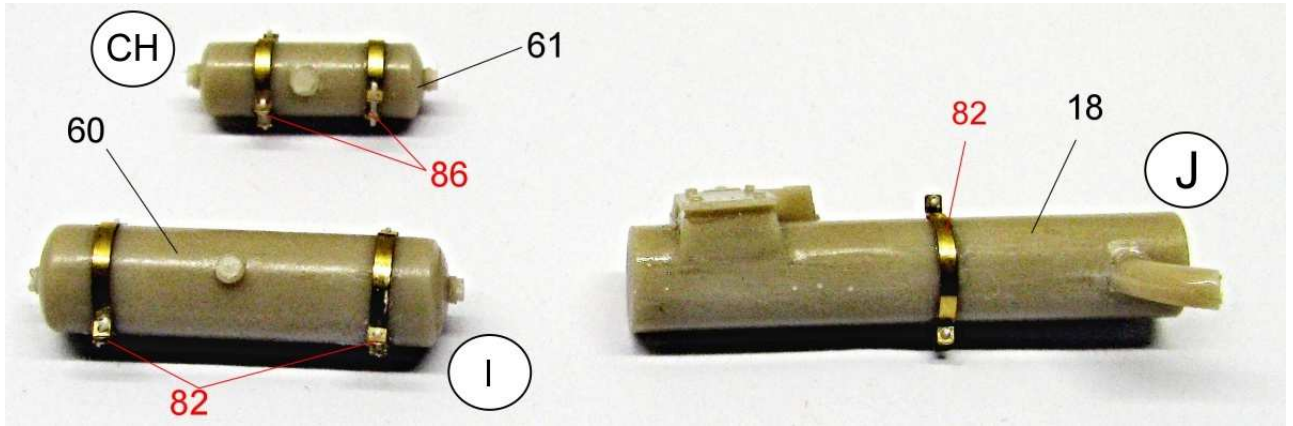

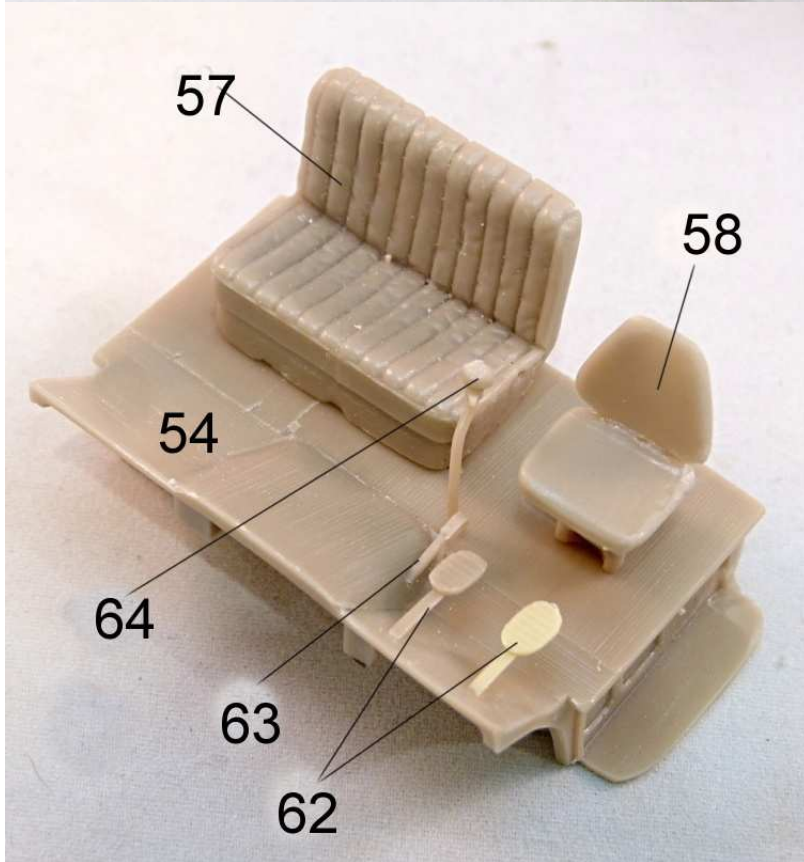
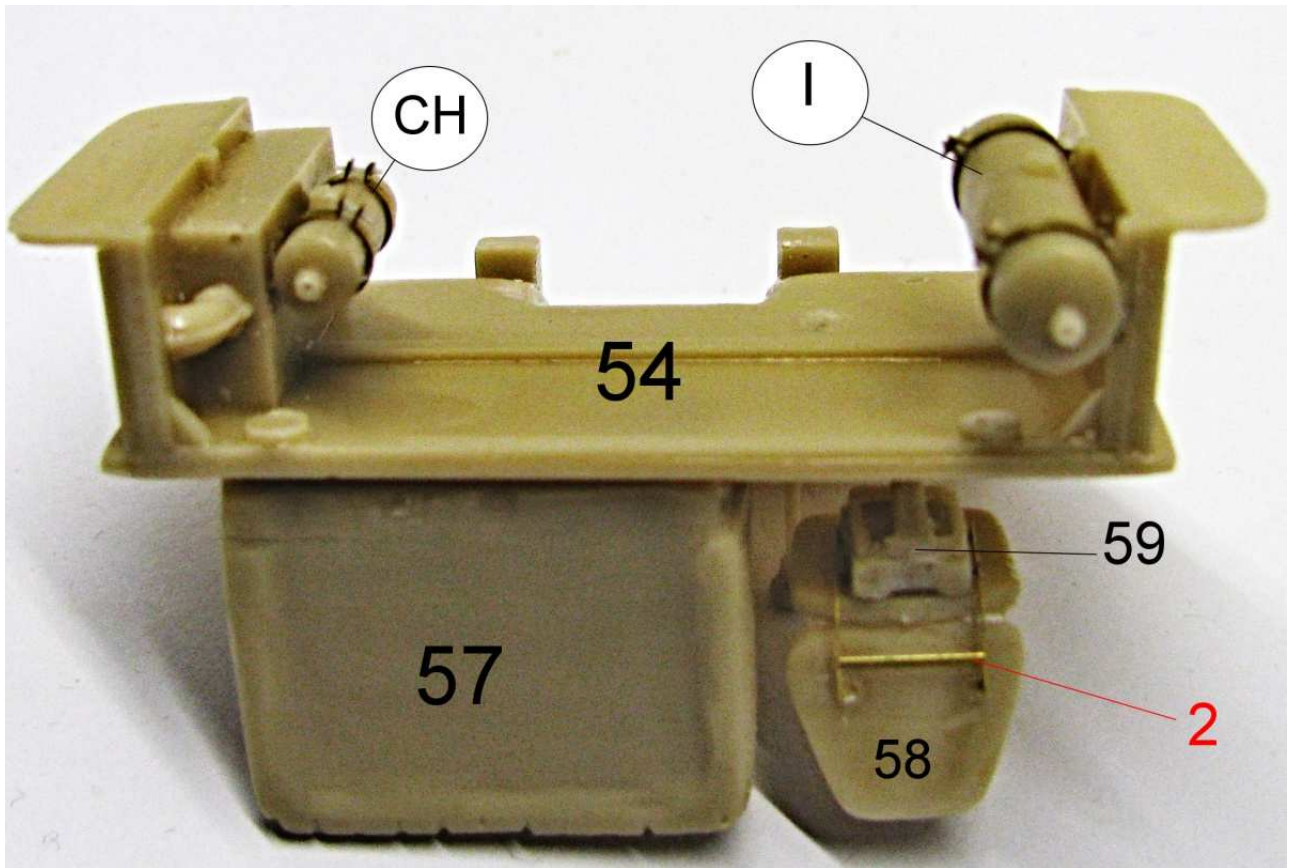



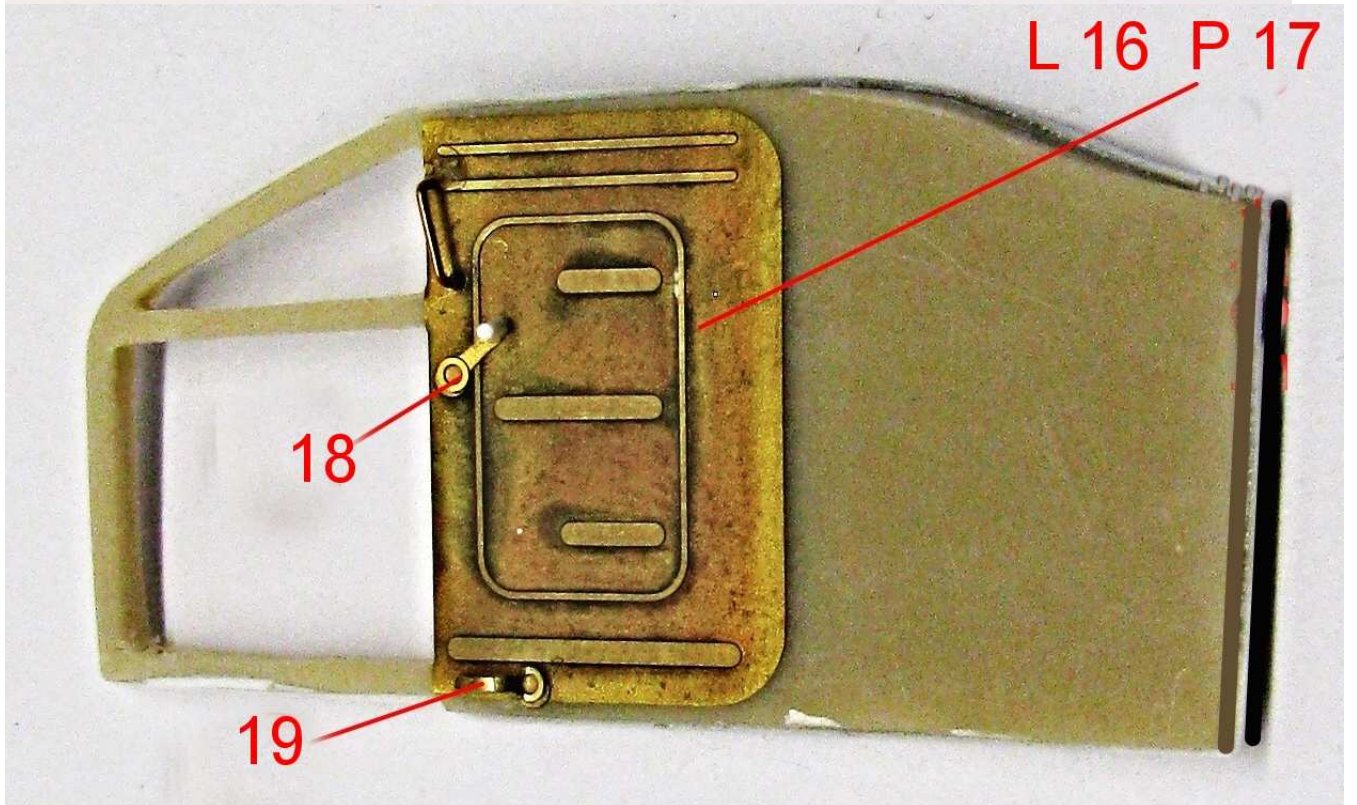
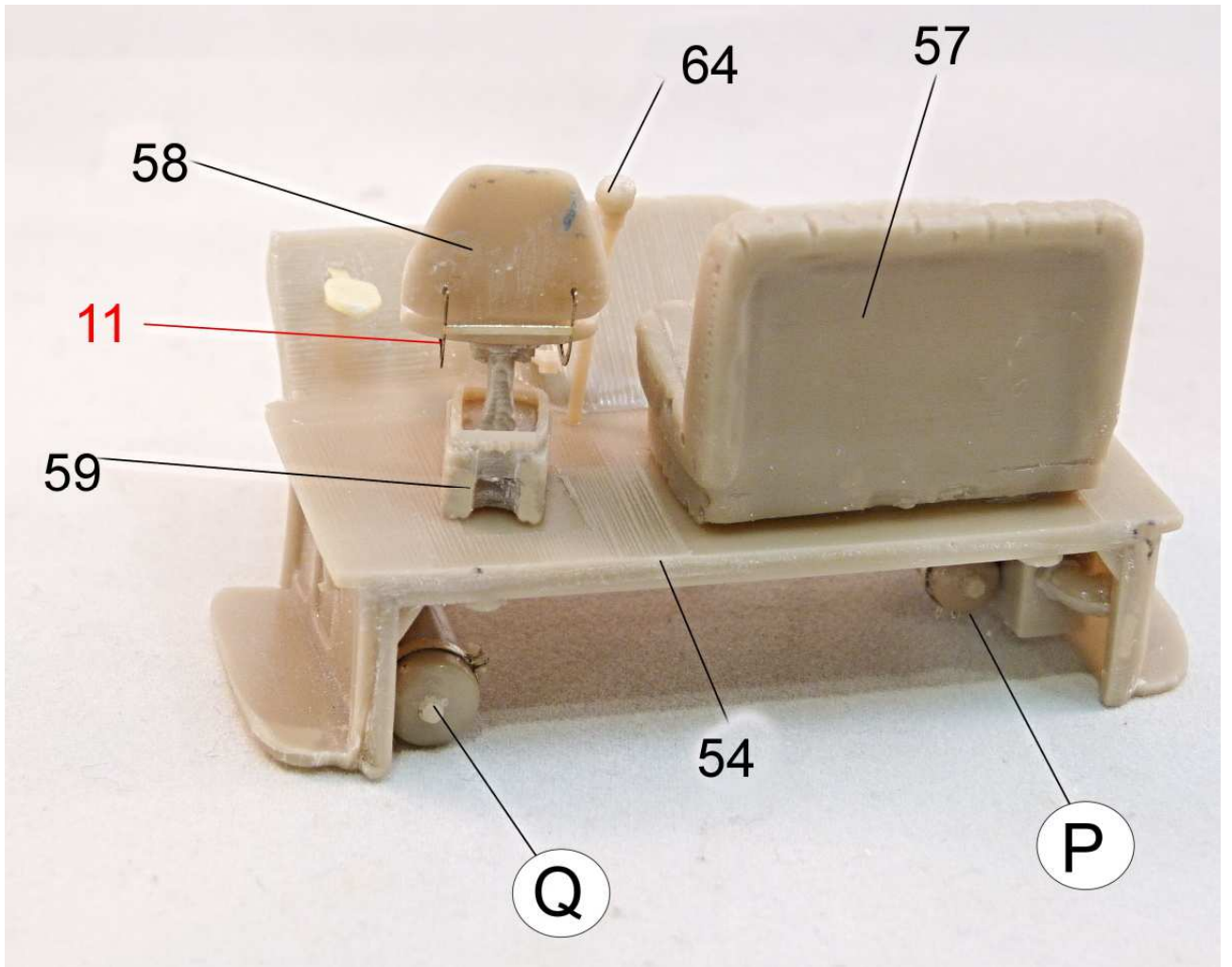

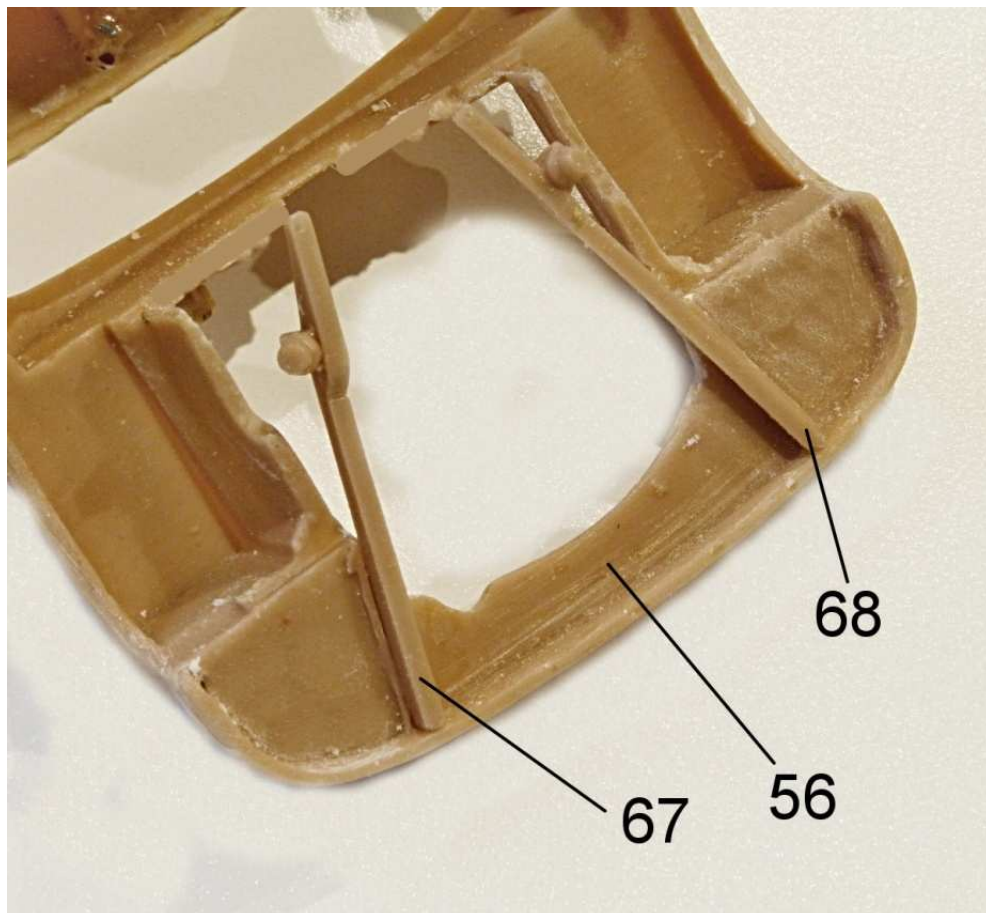
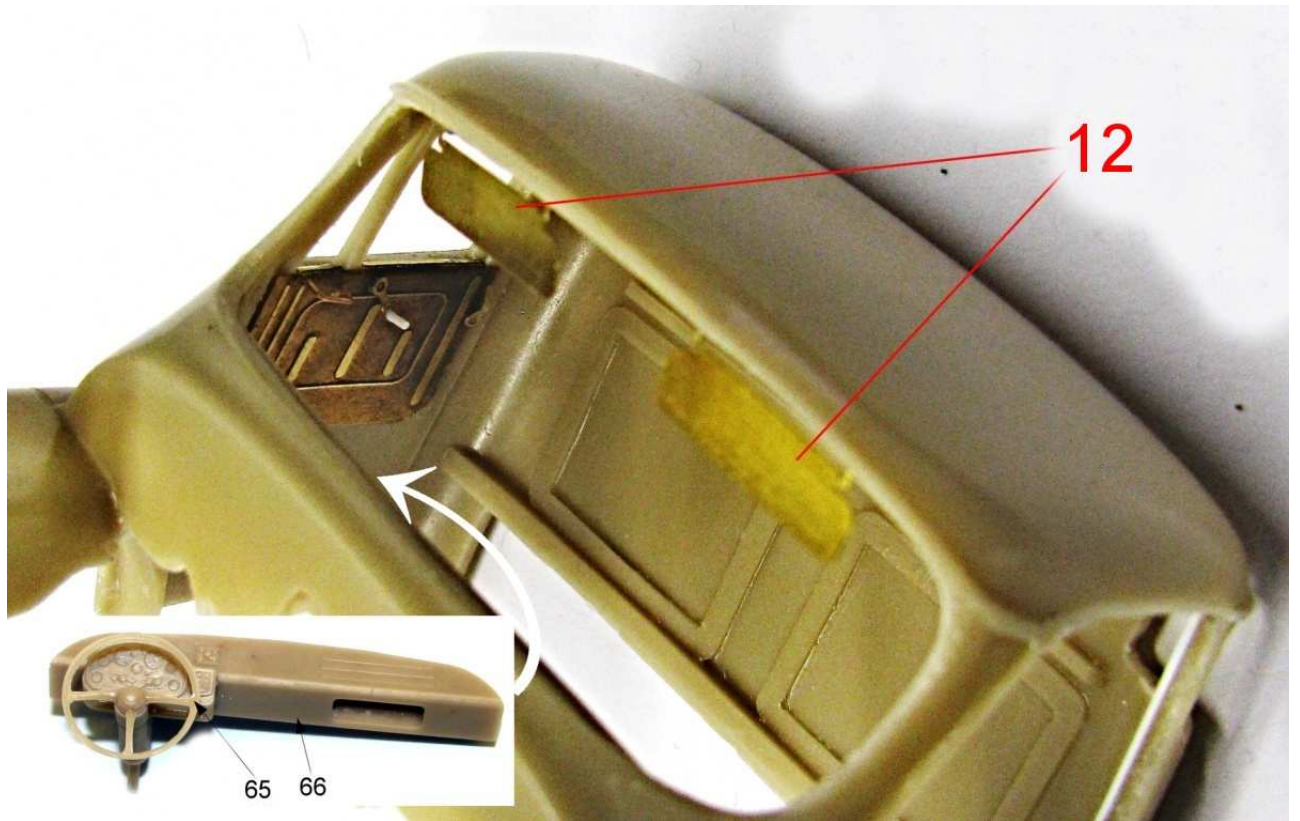



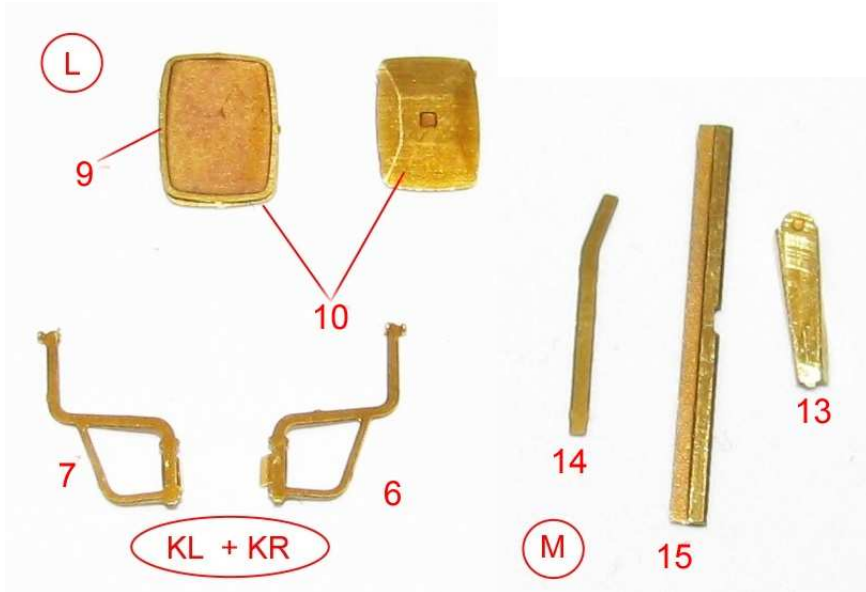
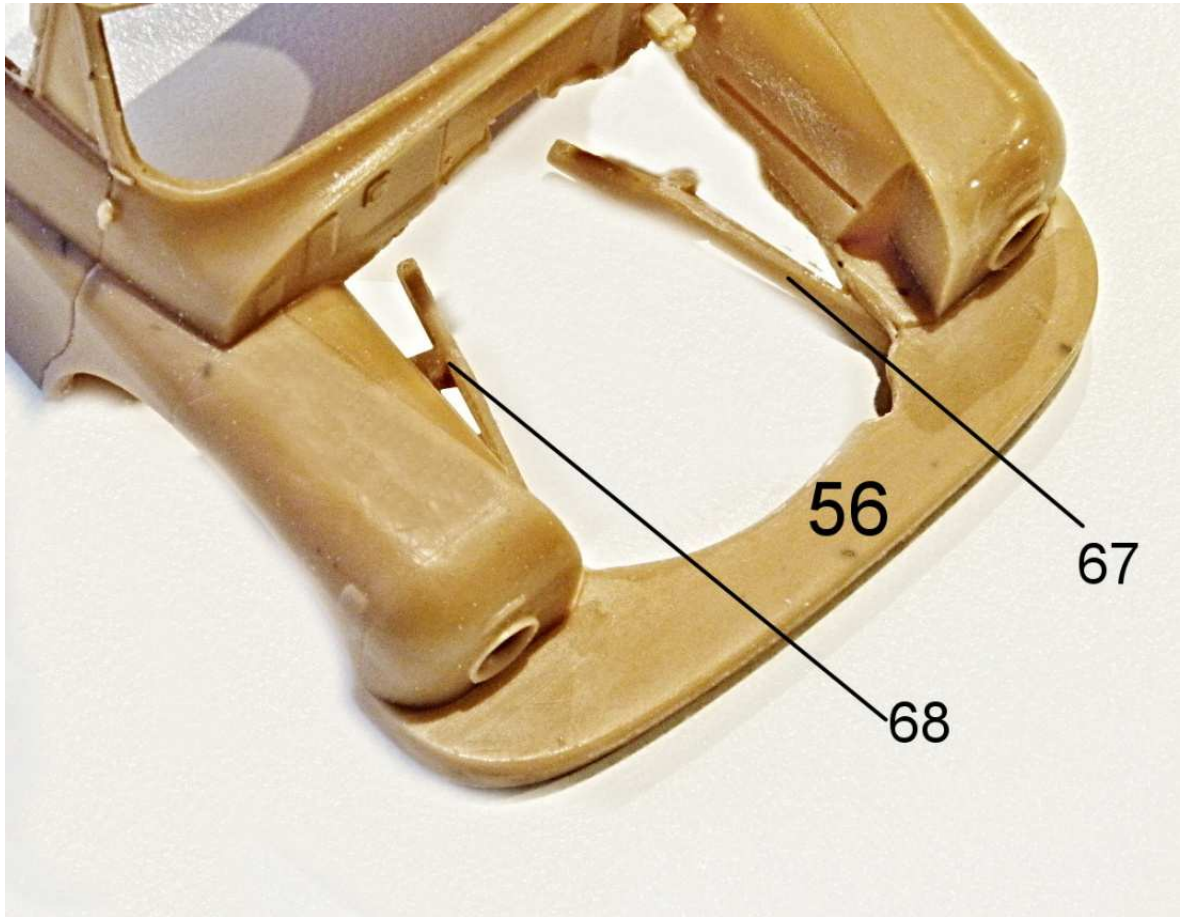

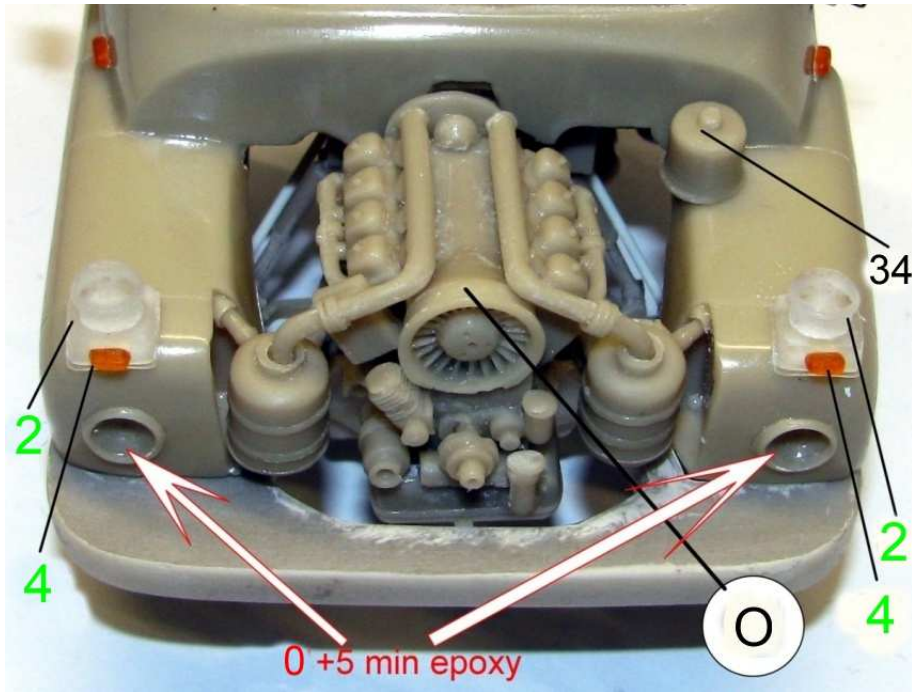
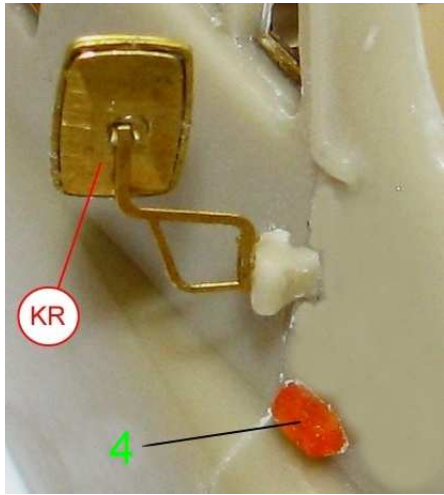



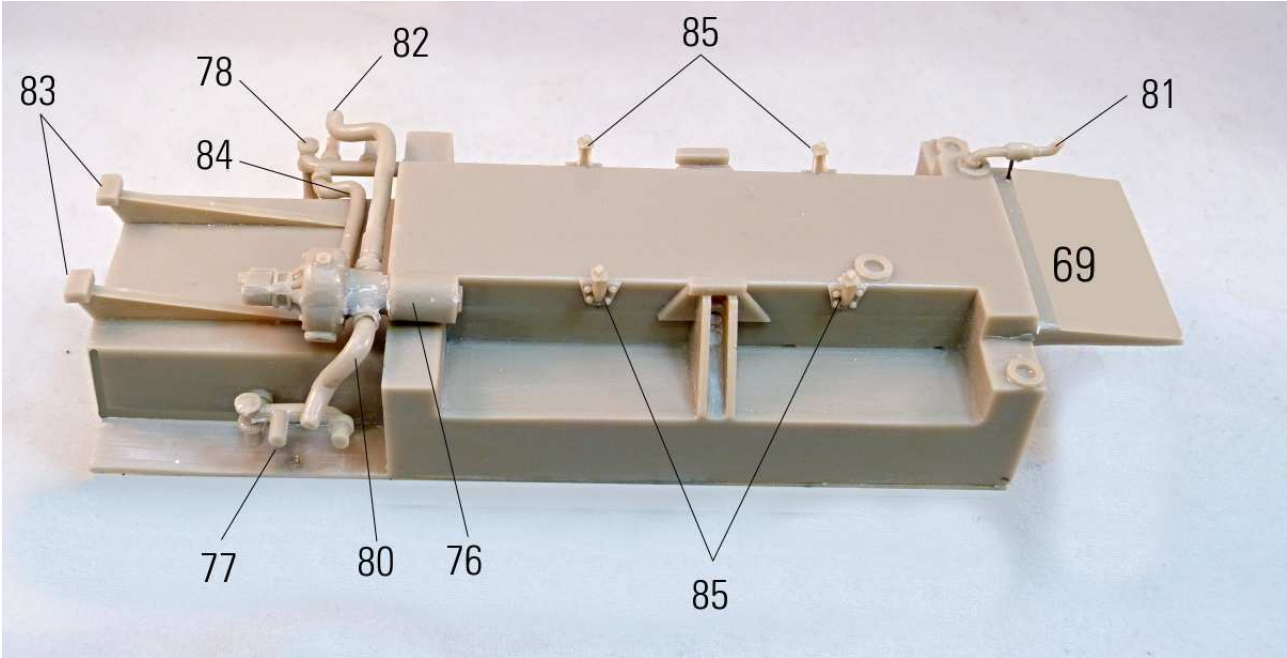
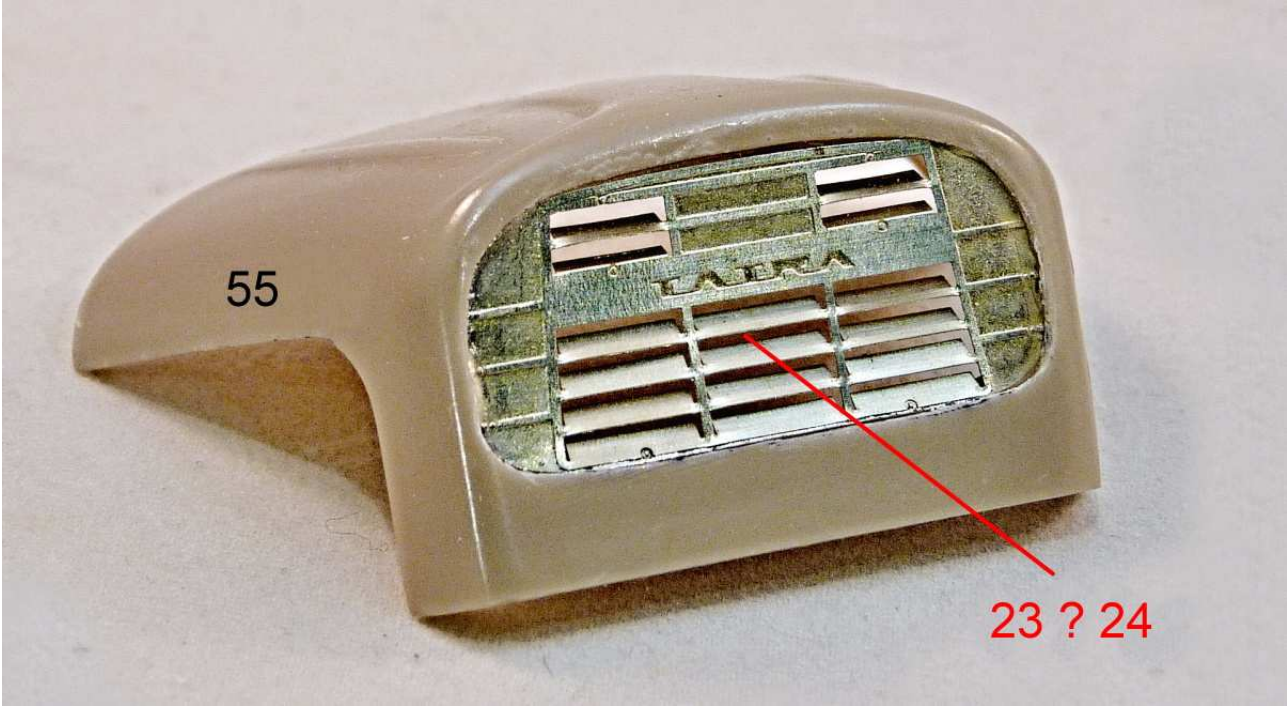

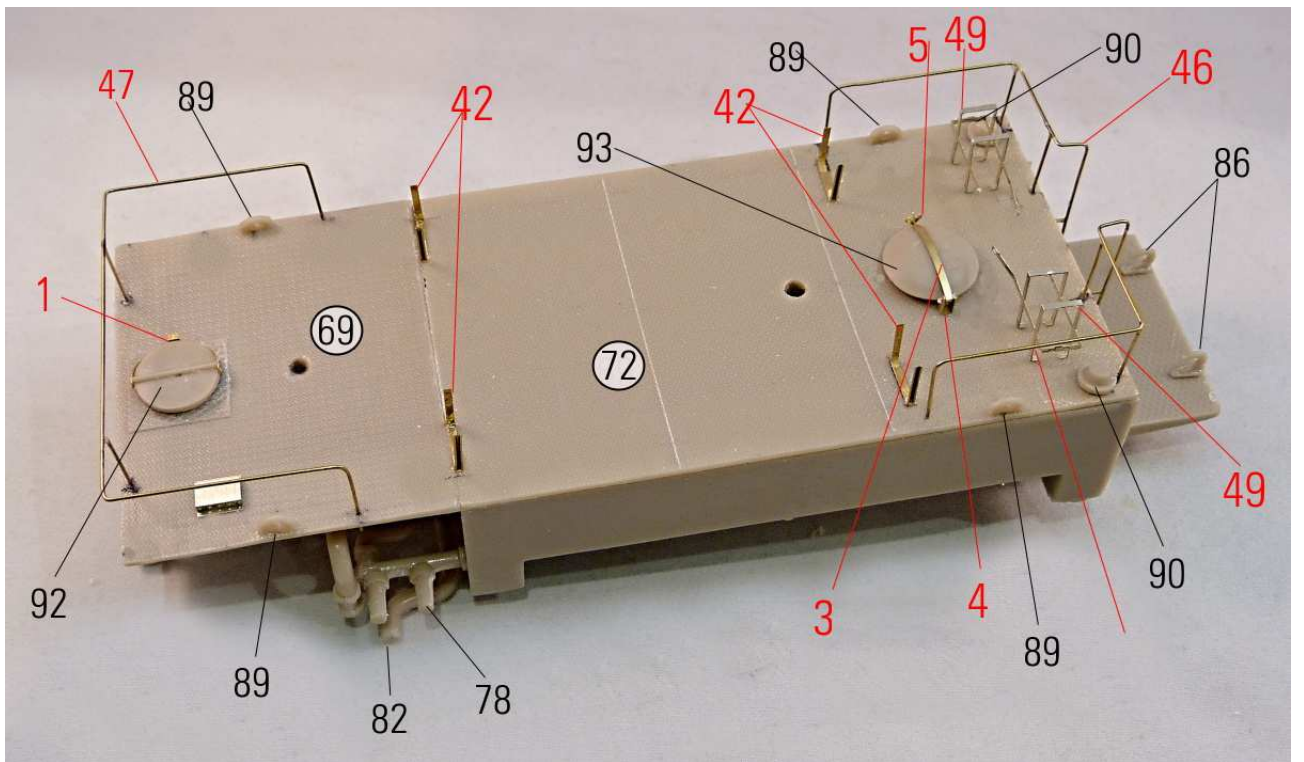
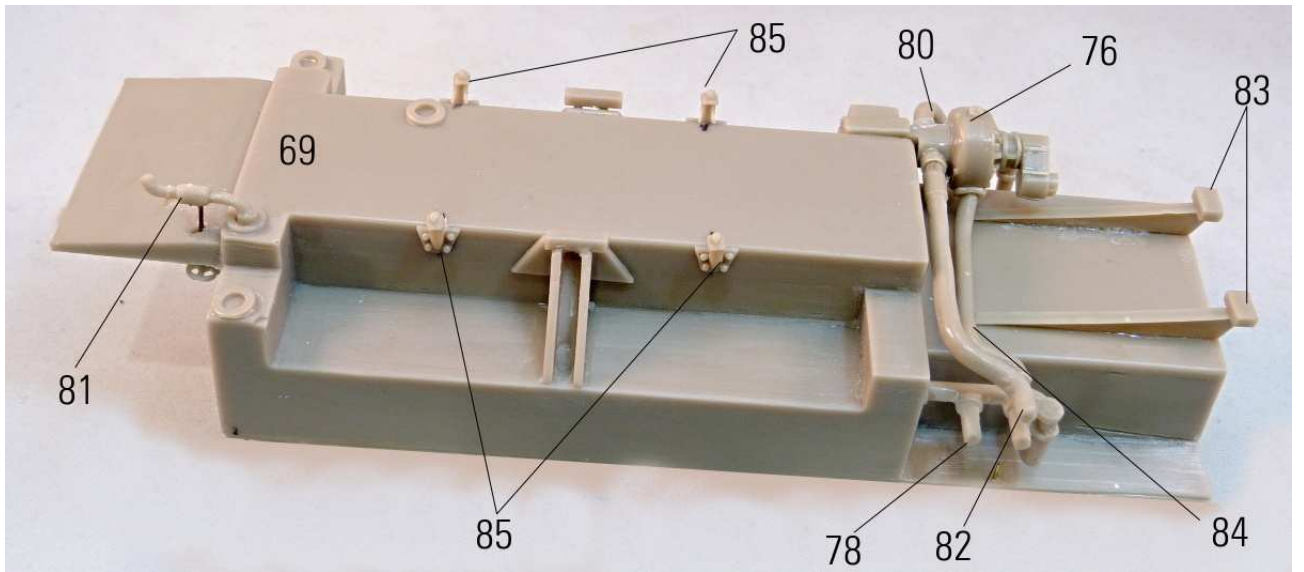



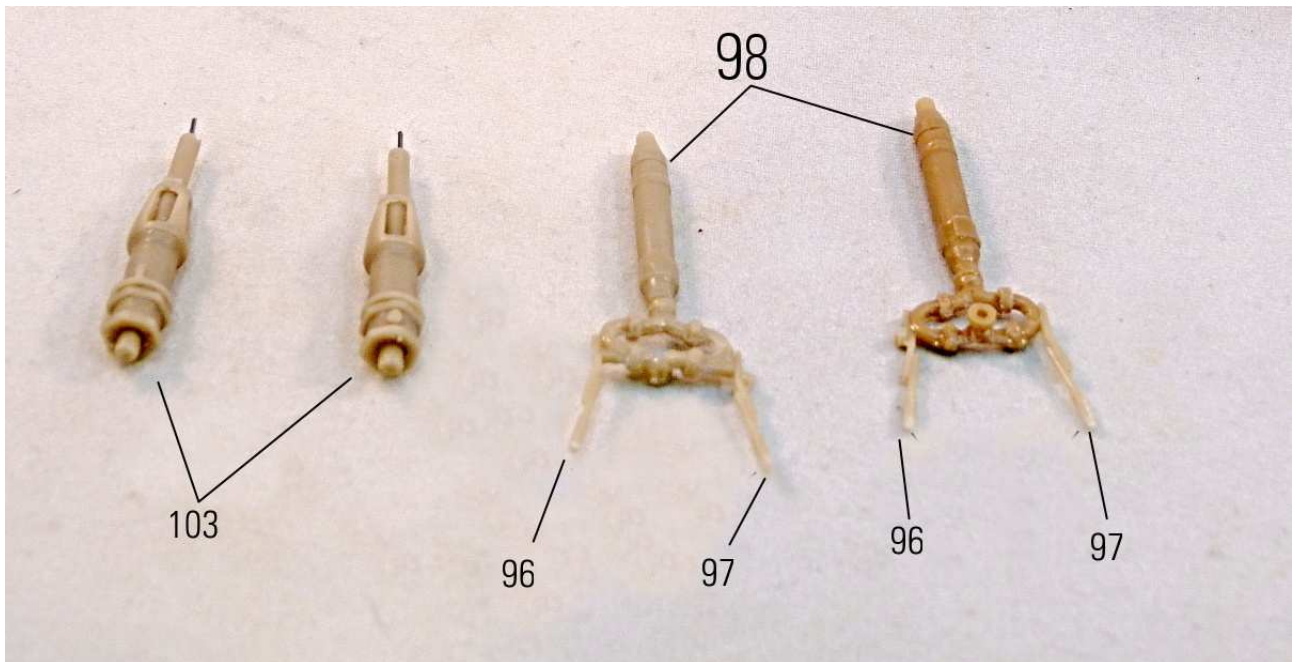
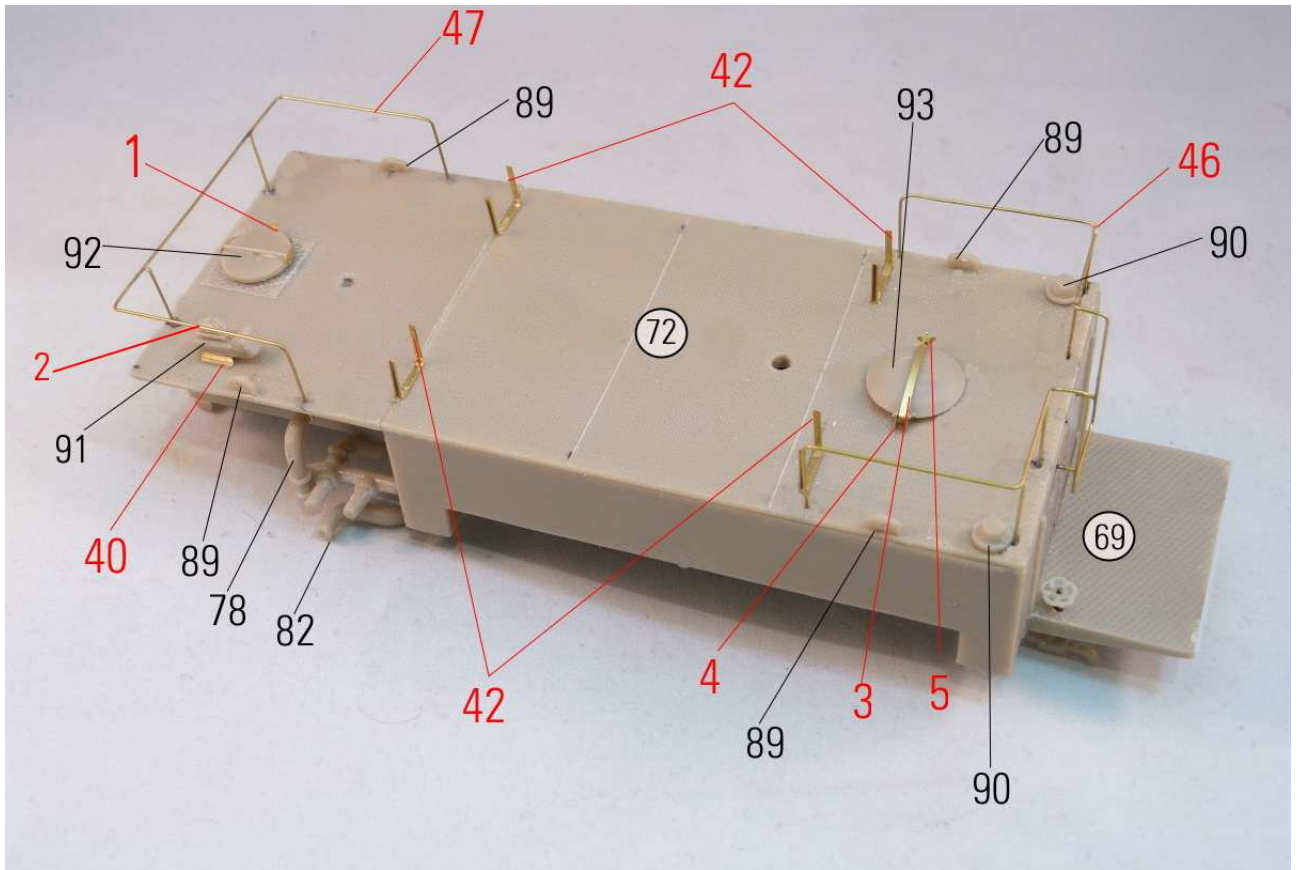

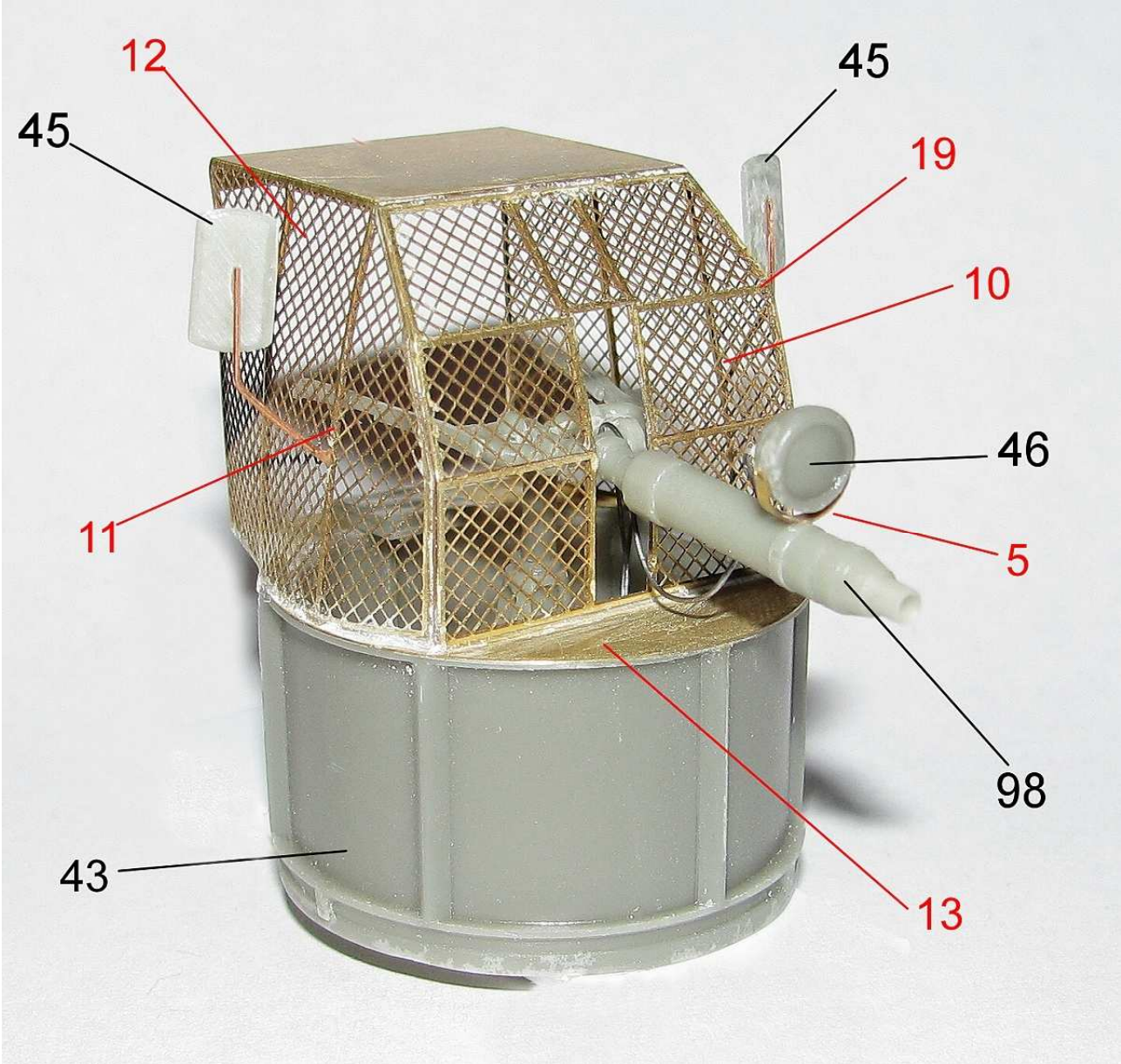



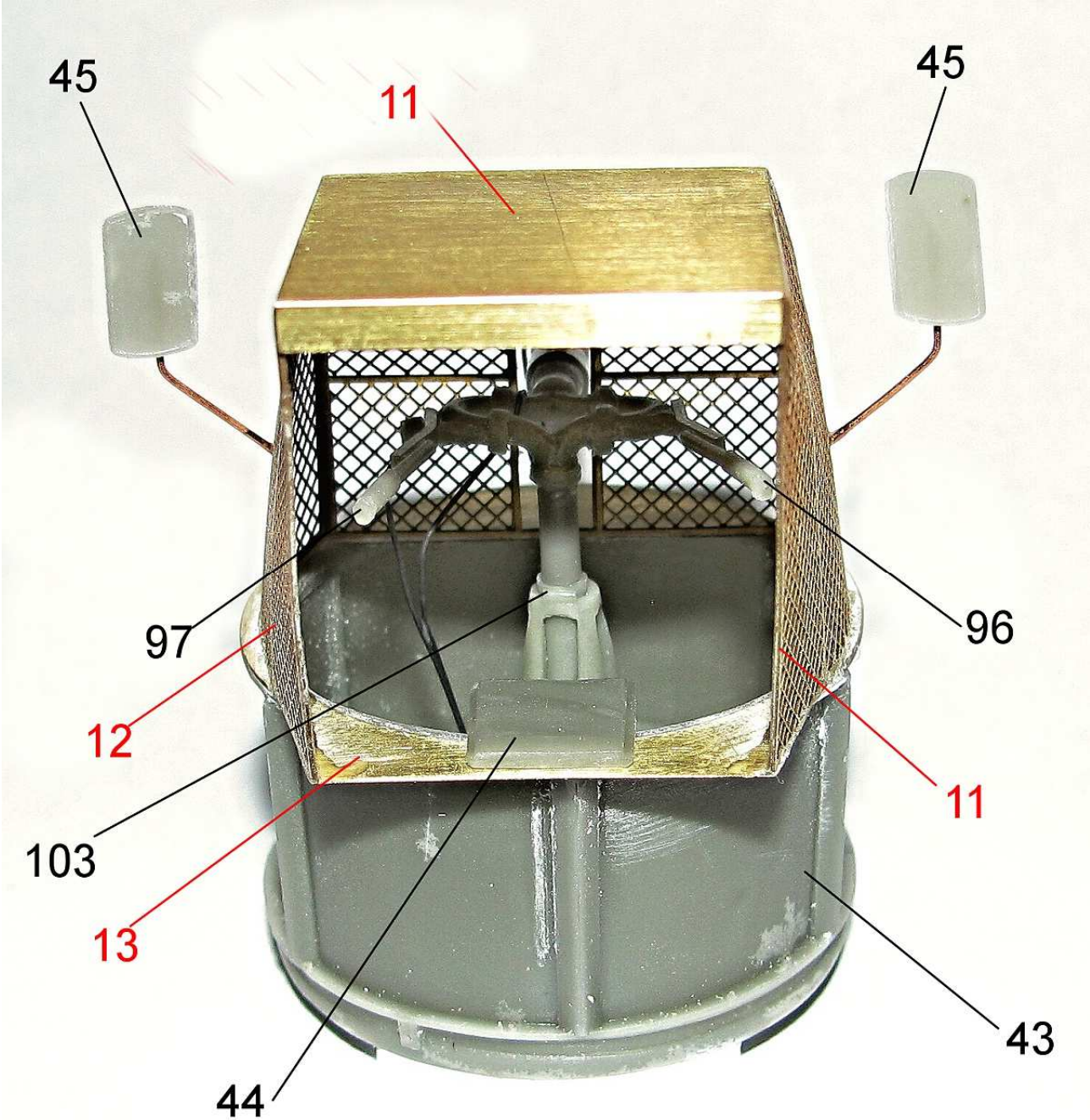





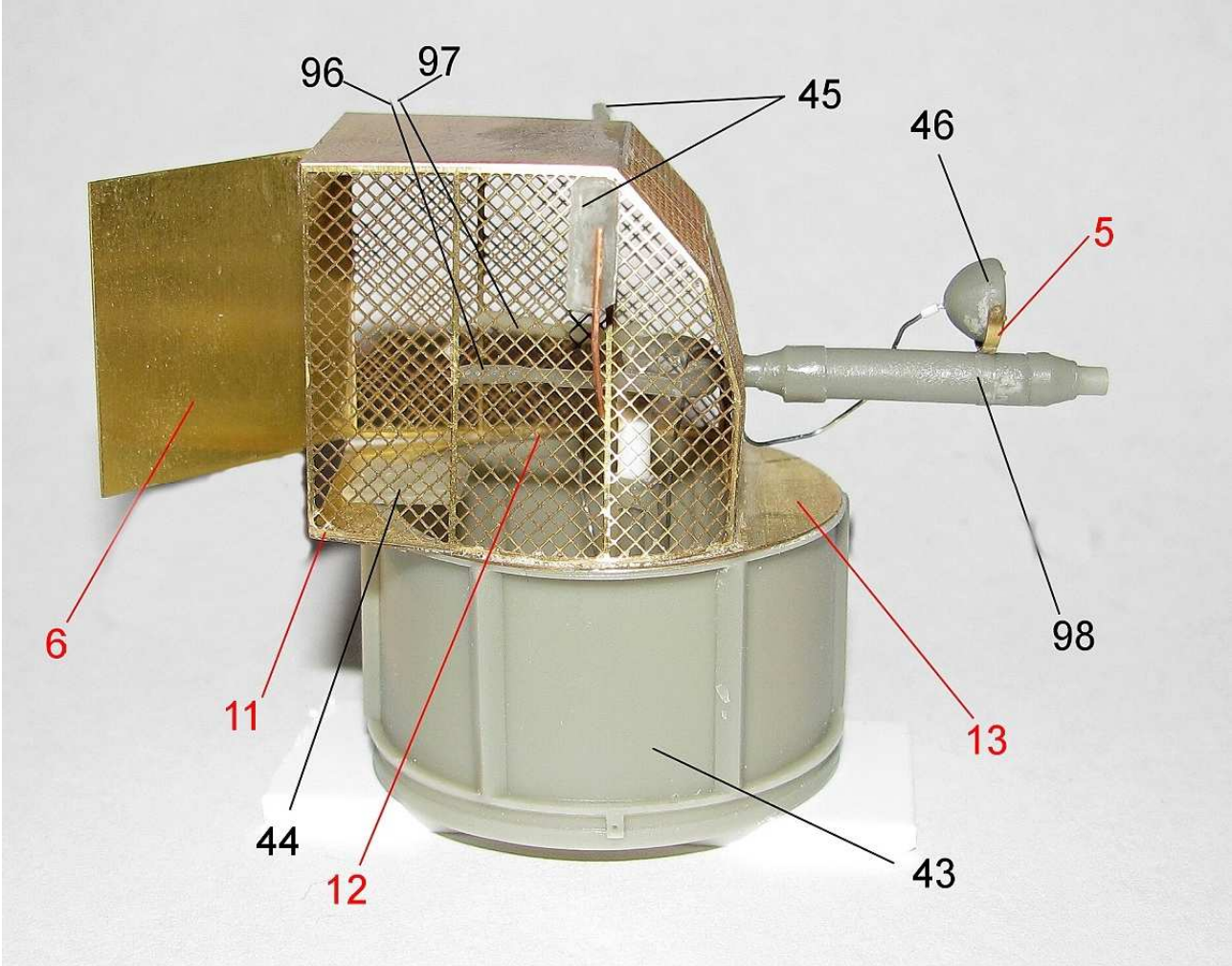











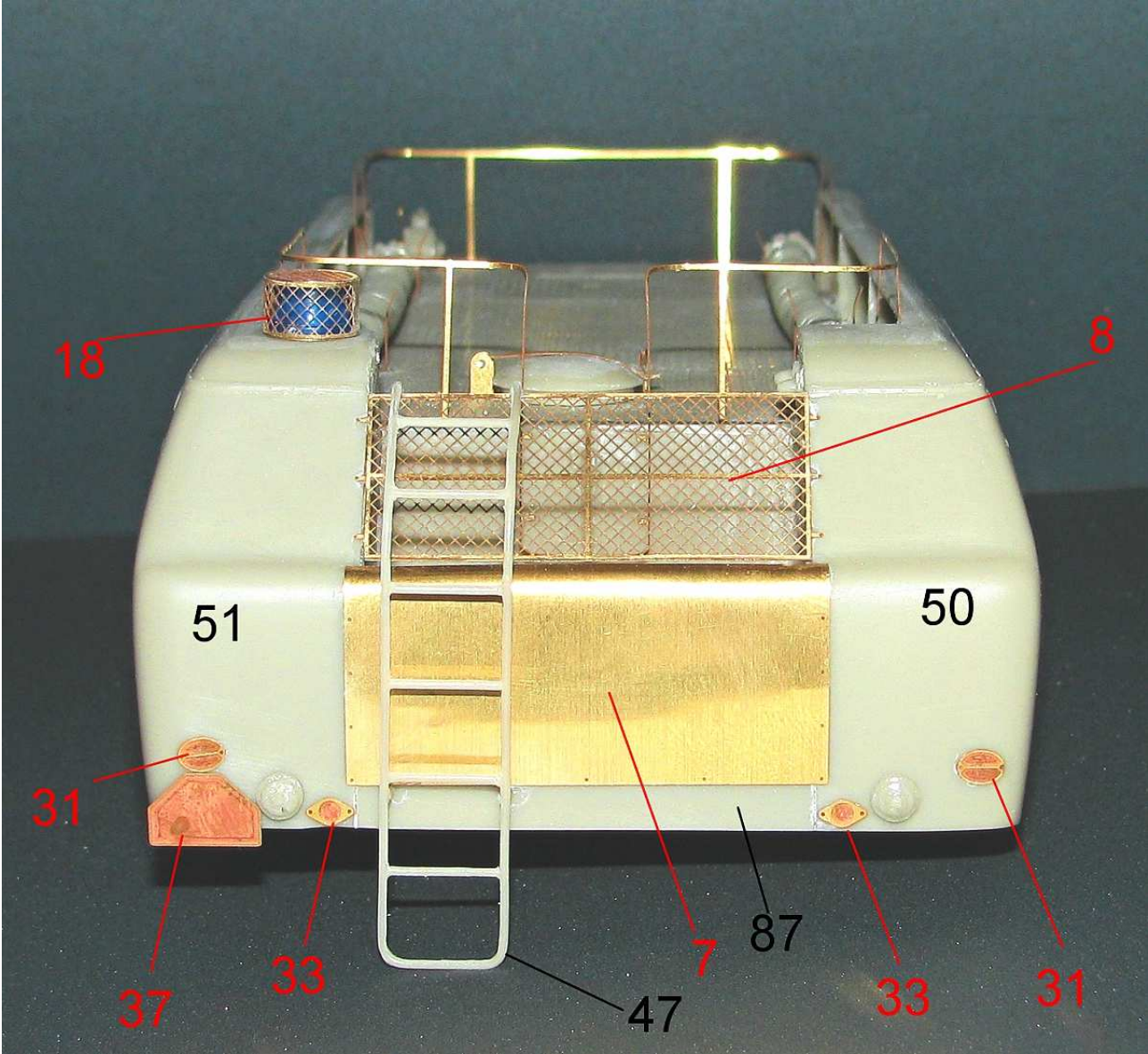

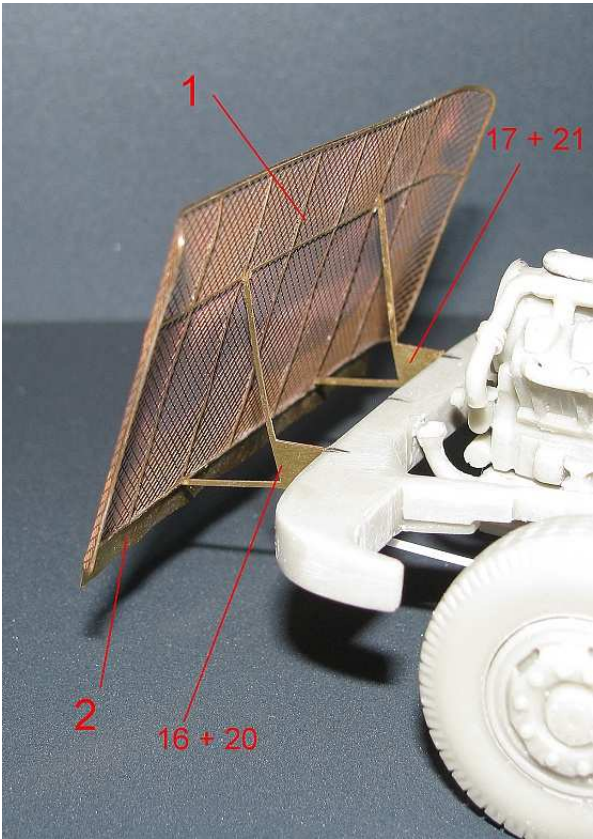
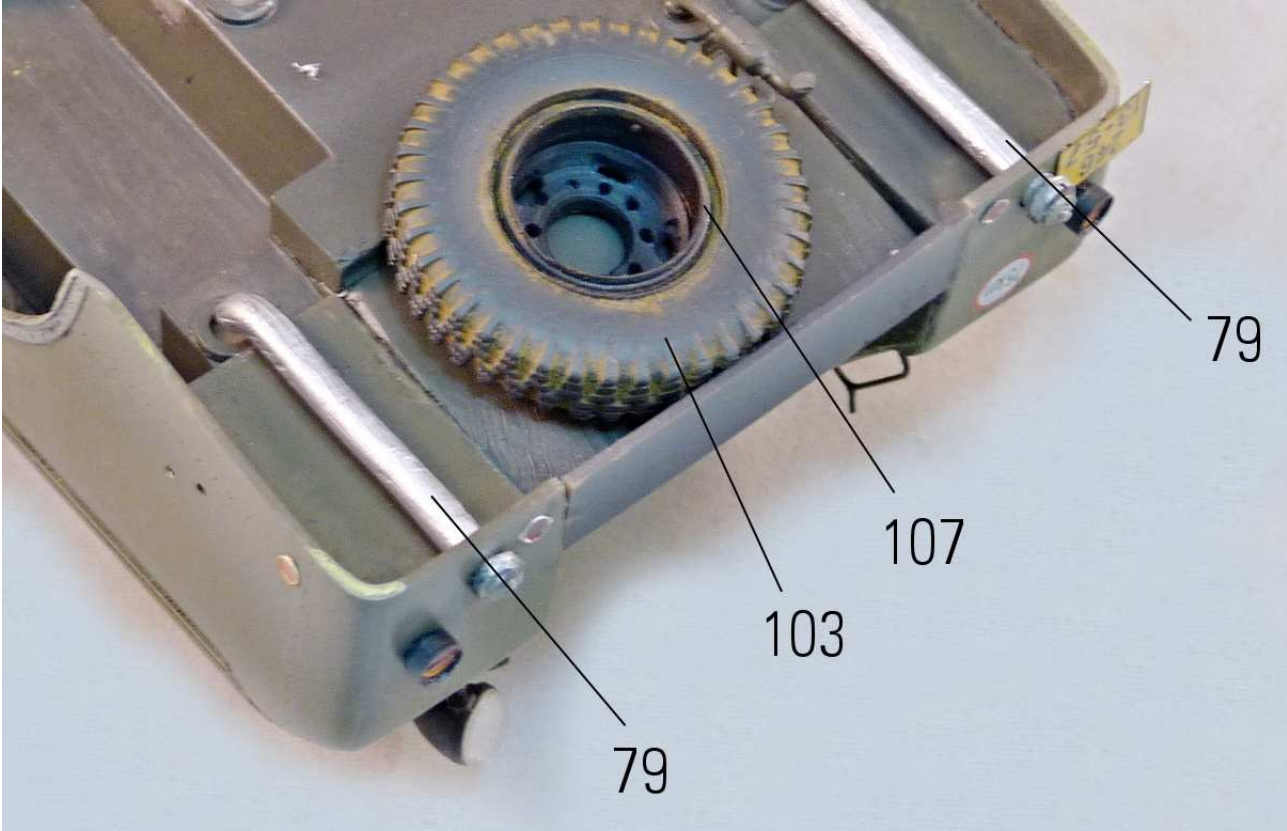



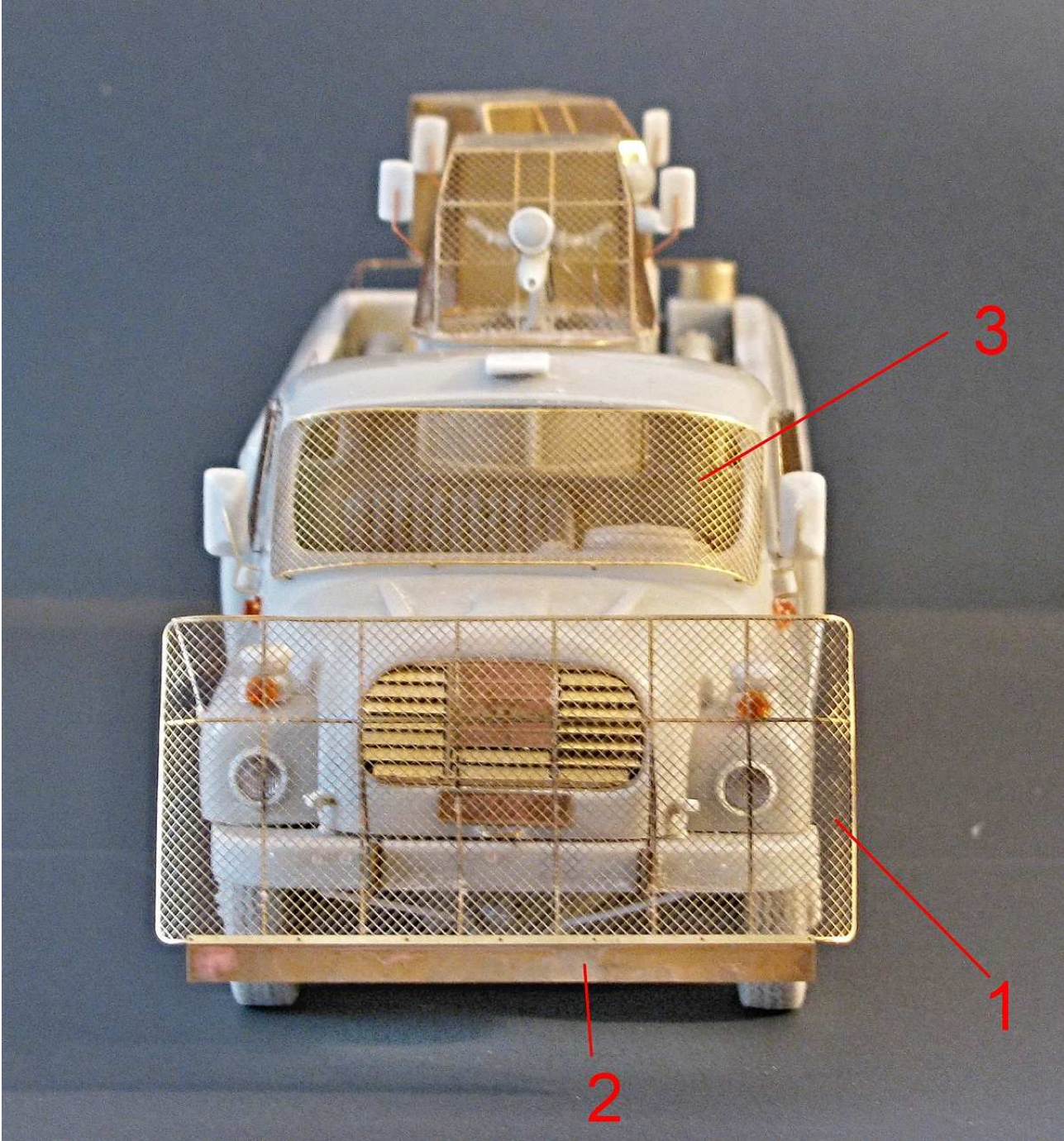

Optional:

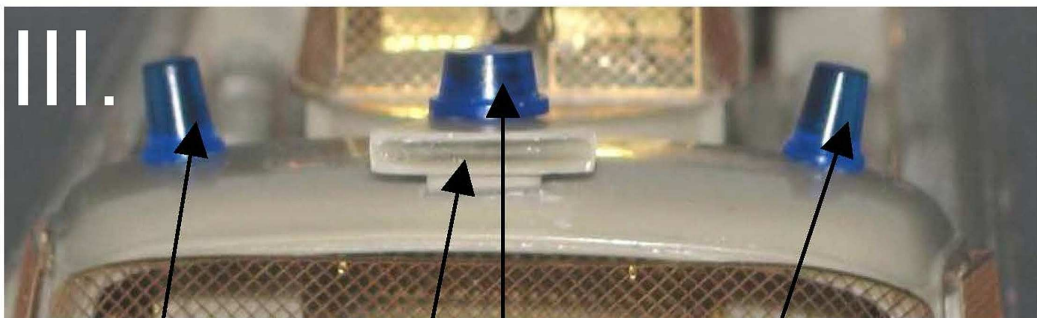
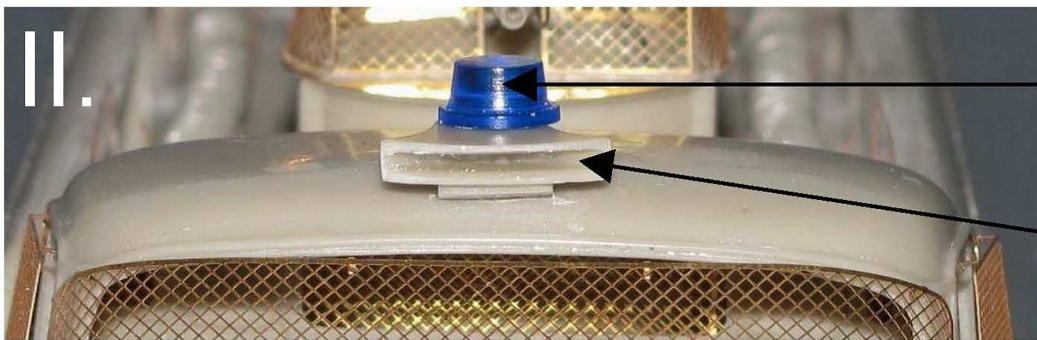
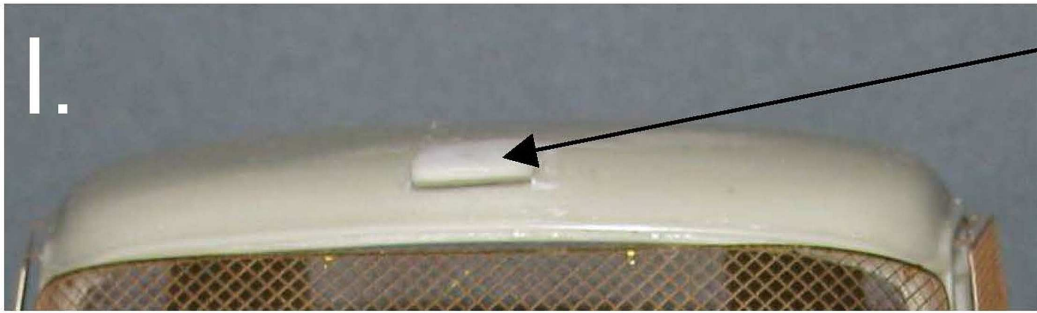



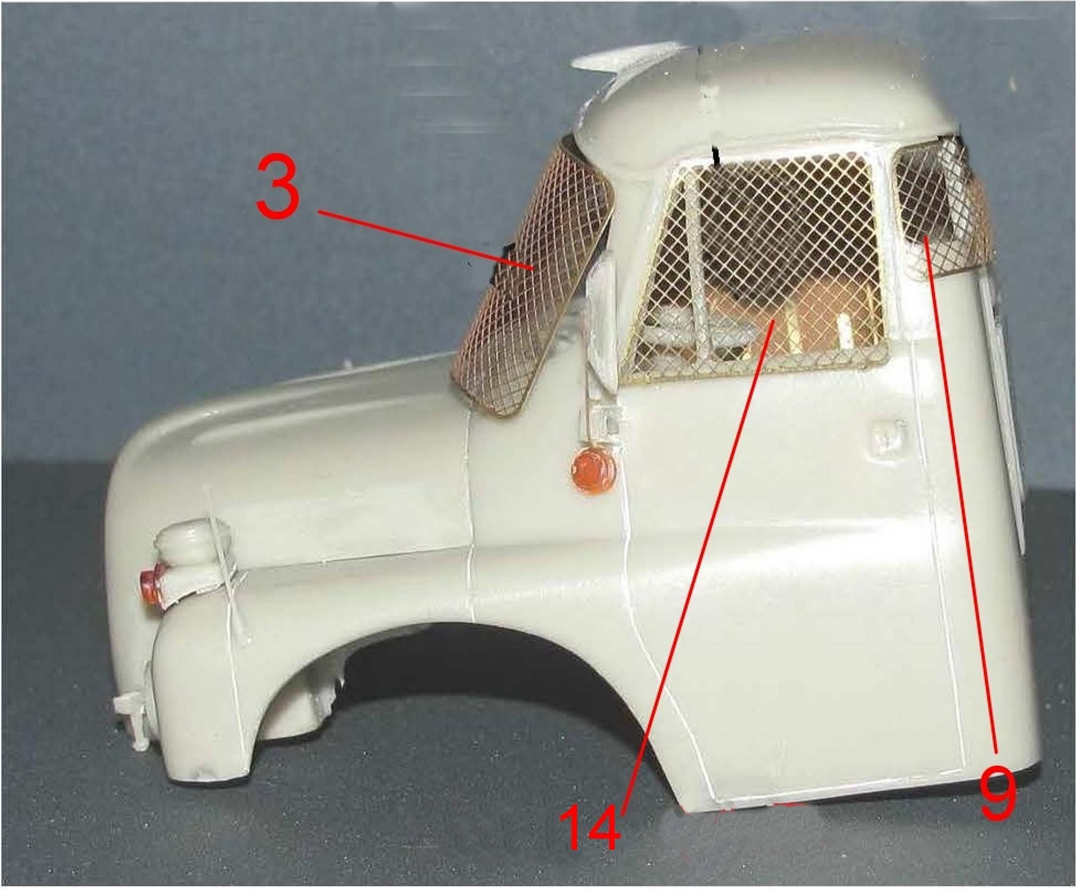

14

9

15

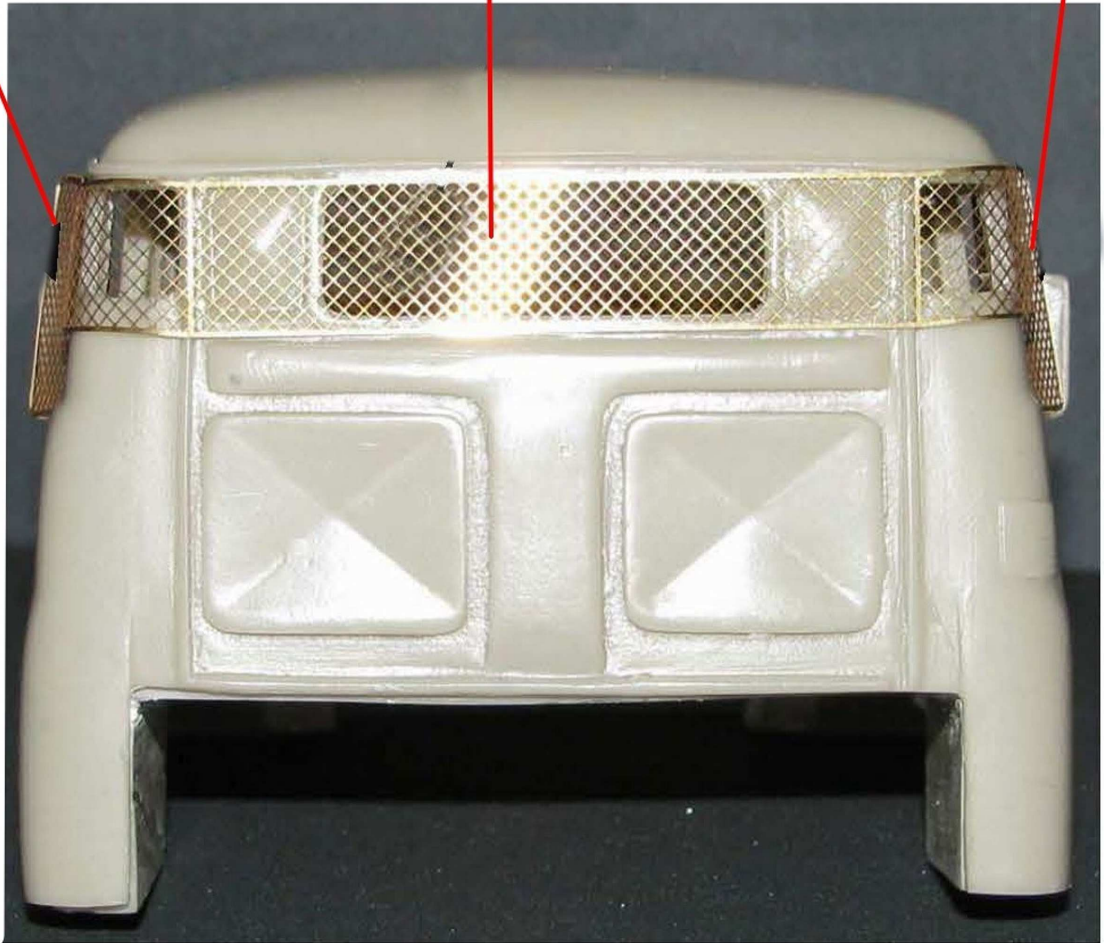



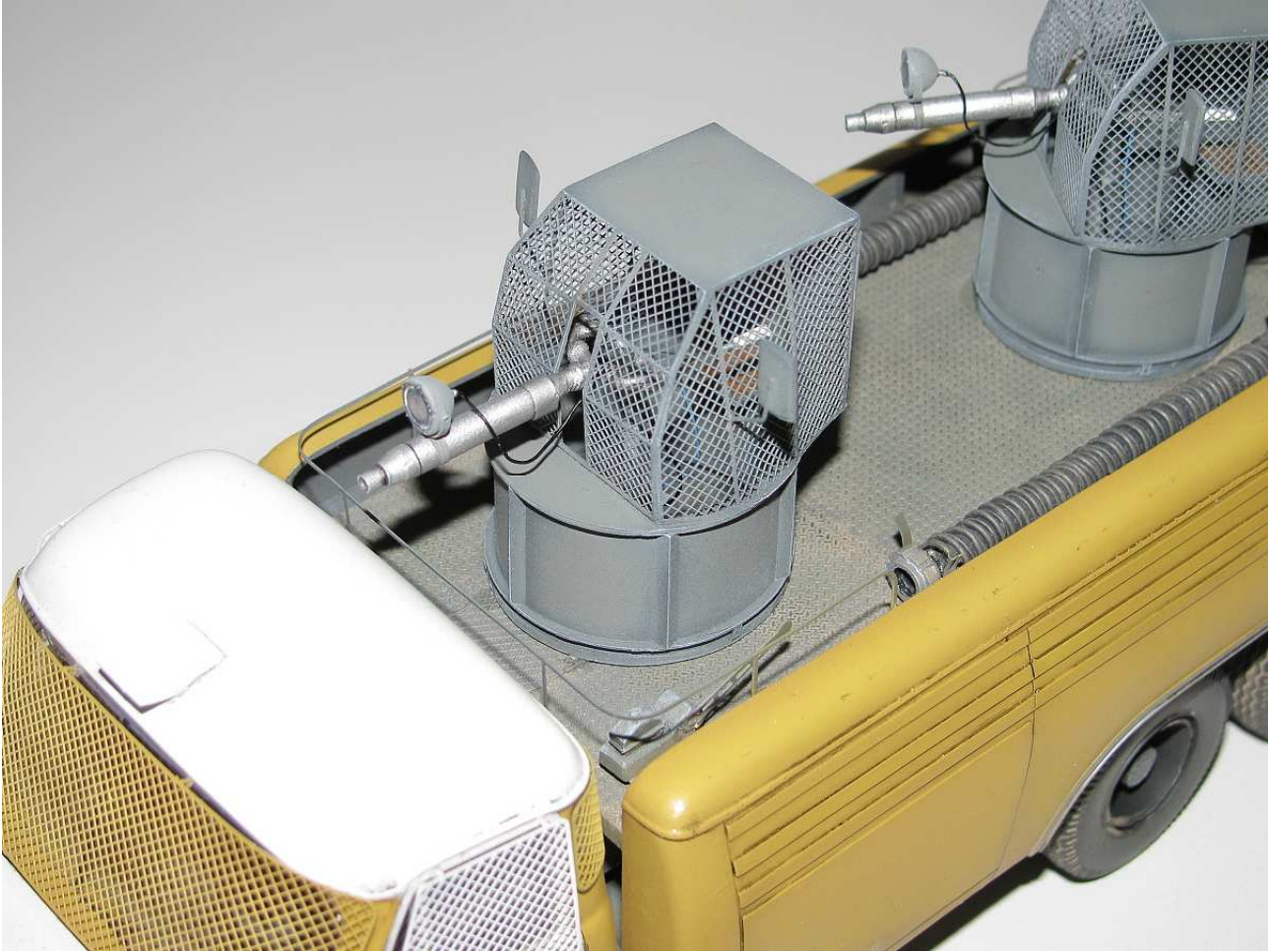

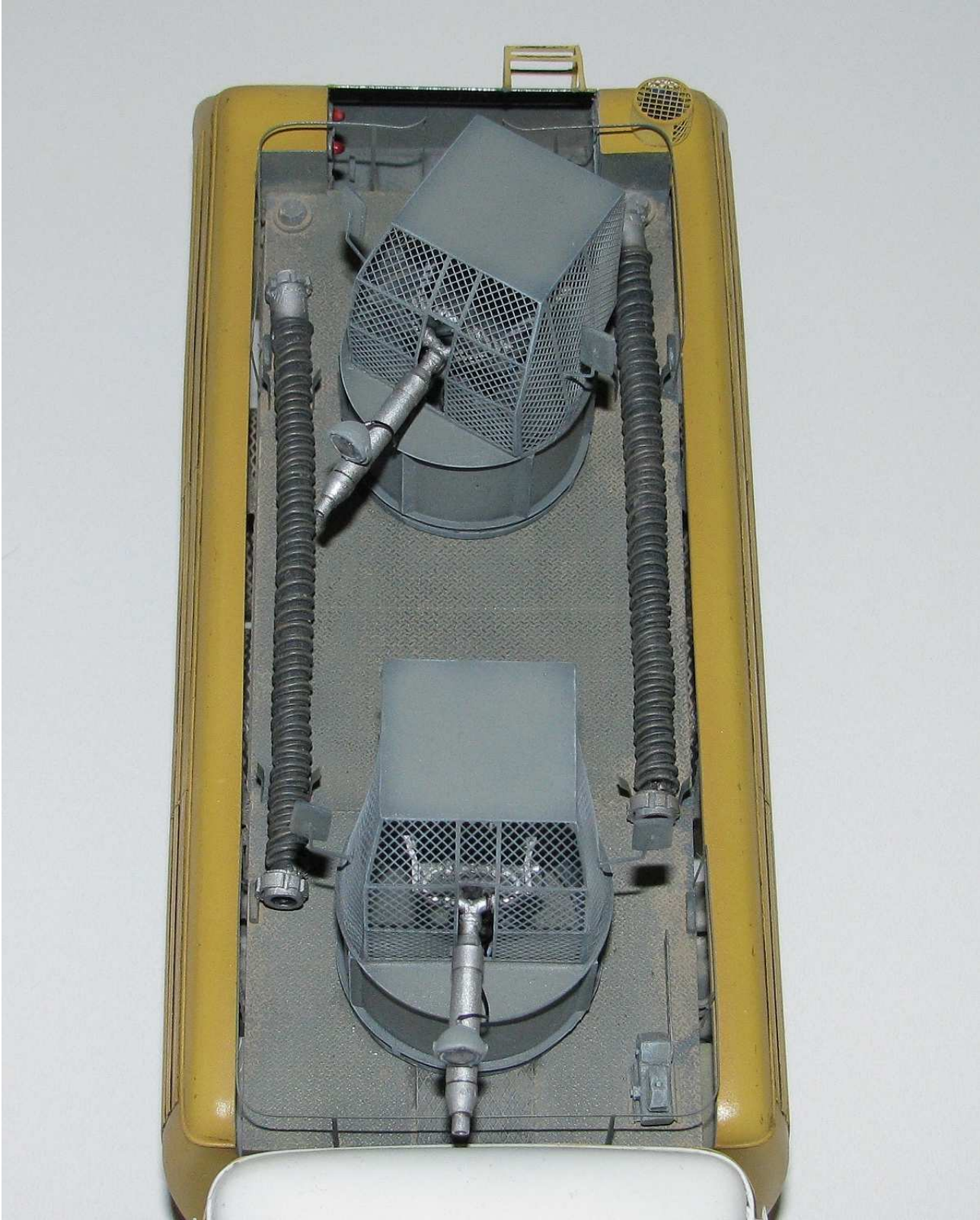











**Tatra 148 CAS32 VB** patřící do stavu SNB, VB, Praha 1989  
(SNB -Sbor národní bezpečnosti, VB – Veřejná bezpečnost)





Vozidla byla používána v různých konfiguracích a zbarveních (žlutá-bílá, zelená-bílá, ...).  
Při dokončování modelu se řiďte konkrétné předlohou.











